



# Agilent 1200 Series Binary Pump SL



**User Manual**



**Agilent Technologies**

# Notices

© Agilent Technologies, Inc. 2005, 2007-2009

No part of this manual may be reproduced in any form or by any means (including electronic storage and retrieval or translation into a foreign language) without prior agreement and written consent from Agilent Technologies, Inc. as governed by United States and international copyright laws.

## Manual Part Number

G1312-90011

## Edition

02/09

Printed in Germany

Agilent Technologies  
Hewlett-Packard-Strasse 8  
76337 Waldbronn

## Research Use Only

**Not for use in Diagnostic Procedures.**

## Warranty

**The material contained in this document is provided “as is,” and is subject to being changed, without notice, in future editions. Further, to the maximum extent permitted by applicable law, Agilent disclaims all warranties, either express or implied, with regard to this manual and any information contained herein, including but not limited to the implied warranties of merchantability and fitness for a particular purpose. Agilent shall not be liable for errors or for incidental or consequential damages in connection with the furnishing, use, or performance of this document or of any information contained herein. Should Agilent and the user have a separate written agreement with warranty terms covering the material in this document that conflict with these terms, the warranty terms in the separate agreement shall control.**

## Technology Licenses

The hardware and/or software described in this document are furnished under a license and may be used or copied only in accordance with the terms of such license.

## Restricted Rights Legend

If software is for use in the performance of a U.S. Government prime contract or subcontract, Software is delivered and licensed as “Commercial computer software” as defined in DFAR 252.227-7014 (June 1995), or as a “commercial item” as defined in FAR 2.101(a) or as “Restricted computer software” as defined in FAR 52.227-19 (June 1987) or any equivalent agency regulation or contract clause. Use, duplication or disclosure of Software is subject to Agilent Technologies’ standard commercial license terms, and non-DOD Departments and Agencies of the U.S. Government will

receive no greater than Restricted Rights as defined in FAR 52.227-19(c)(1-2) (June 1987). U.S. Government users will receive no greater than Limited Rights as defined in FAR 52.227-14 (June 1987) or DFAR 252.227-7015 (b)(2) (November 1995), as applicable in any technical data.

## Safety Notices

### CAUTION

A **CAUTION** notice denotes a hazard. It calls attention to an operating procedure, practice, or the like that, if not correctly performed or adhered to, could result in damage to the product or loss of important data. Do not proceed beyond a **CAUTION** notice until the indicated conditions are fully understood and met.

### WARNING

A **WARNING** notice denotes a hazard. It calls attention to an operating procedure, practice, or the like that, if not correctly performed or adhered to, could result in personal injury or death. Do not proceed beyond a **WARNING** notice until the indicated conditions are fully understood and met.

# Contents

<b>1</b>	<b>Introduction to the Binary Pump SL</b>	<b>7</b>
	Instrument and Operation	8
	How Does the Binary Pump SL Work?	14
	Electrical Connections	21
	The Electronics	23
	Agilent 1200 Series Interfaces	24
<b>2</b>	<b>Site Requirements and Specifications</b>	<b>25</b>
	Site Requirements	26
	Physical Specifications	29
	Performance Specifications	30
<b>3</b>	<b>Installing the Pump</b>	<b>33</b>
	Unpacking the Binary Pump SL	34
	Optimizing the Stack Configuration	36
	Installing the Binary Pump SL	43
	Flow Connections with Solvent Selection Valve	46
	Flow Connections without Solvent Selection Valve	49
	Priming the System	52
<b>4</b>	<b>Using the Pump</b>	<b>57</b>
	Hints for Successful Use of the Binary Pump SL	58
	Setting up the Pump with the G4208A Instant Pilot	60
	Setting up the Pump with Agilent ChemStation	61
	Early Maintenance Feedback (EMF)	70

<b>5</b>	<b>Optimizing Performance</b>	<b>73</b>
	Prevent Blocking of Solvent Filters	74
	When to Use a Vacuum Degasser	76
	When to Use the Active Seal Wash Option	77
	When to Use Alternative Seals	78
	When to Use the Low volume mixer	79
	When to Remove Damper and Mixer	80
	How to Optimize the Compressibility Compensation Setting	83
<b>6</b>	<b>Troubleshooting and Diagnostics</b>	<b>87</b>
	Overview of the Pump's Indicators and Test Functions	88
	Status Indicators	90
	User Interfaces	92
	Agilent Lab Advisor software	93
<b>7</b>	<b>Tests and Calibration Functions</b>	<b>95</b>
	Pressure Test Description	96
	Pump Test	101
	Binary Pump SL Solvent Calibration	103
<b>8</b>	<b>Diagnostic Signals</b>	<b>105</b>
	Analog Pressure Output	106
	Diagnostic Signals in the ChemStation Software	107
	Early Maintenance Feedback (EMF)	108
<b>9</b>	<b>Maintenance</b>	<b>111</b>
	Introduction to Maintenance and Repair	112
	Warnings and Cautions	113
	Cleaning the module	114
	Using the ESD Strap	115
	Overview of Maintenance and Simple Repairs	116
	Maintenance Procedures	117
	Simple Repair Procedures	132

**10 Parts and Materials for Maintenance 145**

Bottle Head Assembly	146
Hydraulic Path with Solvent Selection Valve	148
Hydraulic Path without Solvent Selection Valve	150
Pump-Head Assembly SL	152
Outlet Ball Valve Assembly	154
Purge Valve Assembly	155
Active Inlet Valve Assembly	156
Accessory Kit G1312-68725	157
Active Seal Wash Option G1312-68721	158
G1316B SL Capillary System Kit	159

**11 Identifying Cables 161**

Cable Overview	162
Analog Cables	164
Remote Cables	167
BCD Cables	173
External Contact Cable	175
CAN/LAN Cables	176
Auxiliary Cable	177
RS-232 Cables	178

**12 Appendix 179**

General Safety Information	180
The Waste Electrical and Electronic Equipment Directive	184
Lithium Batteries Information	185
Radio Interference	186
Sound Emission	187
Solvent Information	188
Agilent Technologies on Internet	190

## Contents

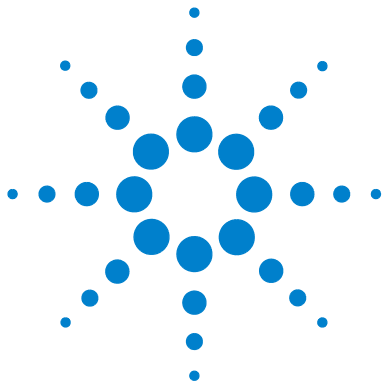

# 1 Introduction to the Binary Pump SL

Instrument and Operation	8
Instrument Layout	8
Principle of Operation	9
Optimization Features	12
How Does the Binary Pump SL Work?	14
Electrical Connections	21
The Electronics	23
Agilent 1200 Series Interfaces	24

## Introduction to the Binary Pump SL



## Instrument and Operation

### Instrument Layout

The Binary Pump SL comprises two identical pumps integrated into one housing. Binary gradients are created by high-pressure mixing. An optional degasser is available for applications that require best flow stability, especially at low flow rates, for maximum detector sensitivity. Pulse damper and mixer can be bypassed for low flowrate applications or whenever a minimal transient volume is desirable. Typical applications are high throughput methods with fast gradients on high resolution 2.1 mm columns. The pump is capable of delivering flow in the range of 0.1 - 5 mL/min against up to 600 bar. A solvent selection valve (optional) allows to form binary mixtures (isocratic or gradient) from one of two solvents per channel. Active seal wash (optional) is available for use with concentrated buffer solutions.

The industrial design of the module incorporates several innovative features. It uses Agilent's E-PAC concept for the packaging of electronics and mechanical assemblies. This concept is based upon the use of expanded polypropylene (EPP) foam plastic spacers in which the mechanical and electronic boards components of the module are placed. This pack is then housed in a metal inner cabinet which is enclosed by a plastic external cabinet. The advantages of this packaging technology are:

- virtual elimination of fixing screws, bolts or ties, reducing the number of components and increasing the speed of assembly/disassembly,
- the plastic layers have air channels molded into them so that cooling air can be guided exactly to the required locations,
- the plastic layers help cushion the electronic and mechanical parts from physical shock, and
- the metal inner cabinet shields the internal electronics from electromagnetic interference and also helps to reduce or eliminate radio frequency emissions from the instrument itself.



## Principle of Operation

The Binary Pump SL is based on a two-channel, dual-piston in-series design which comprises all essential functions that a solvent delivery system has to fulfill. Metering of solvent and delivery to the high-pressure side are performed by two pump assemblies which can generate pressure up to 600 bar.

Each channel comprises a pump assembly including pump drive, pump head, active inlet valve with replaceable cartridge and outlet valve. The two channels are fed into a low-volume mixing chamber which is connected via a restriction capillary coil to a damping unit and a mixer. A pressure sensor monitors the pump pressure. A purge valve with integrated PTFE frit is fitted to the pump outlet for convenient priming of the pumping system.

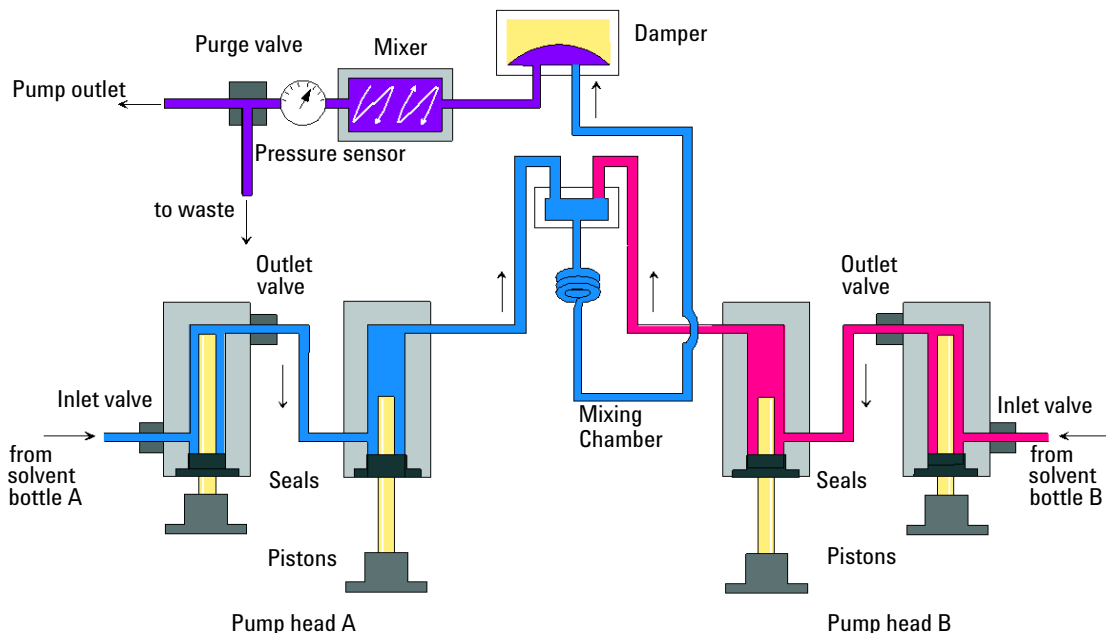

**Figure 1** The Hydraulic Path of the Binary Pump SL with Damper and Mixer

## 1 Introduction to the Binary Pump SL Instrument and Operation

Damper and mixer can be bypassed for lowest delay volume of the Binary Pump SL. This configuration is recommended for low flow rate applications with steep gradients, see the Rapid Resolution System Manual.

Figure [Figure 1](#) on page 9 illustrates the flow path in low delay volume mode. For instructions on how to change between the two configurations, see “[Convert the Binary Pump SL to Low Delay Volume Mode](#)” on page 81.

### NOTE

Bypassing the mixer while the damper remains in line is not a supported configuration and may lead to undesired behavior of the Binary Pump SL.

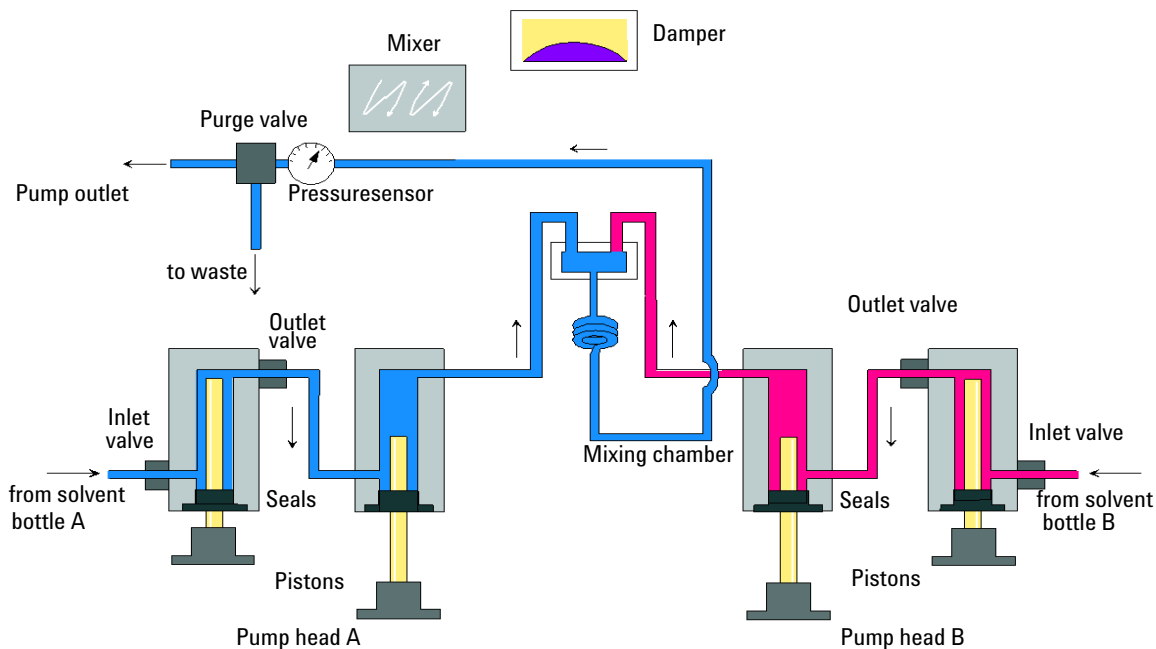

**Figure 2** The Hydraulic Path of the Binary Pump SL with bypassed Damper and Mixer

**Table 1** Pump Details

Delay volume	From mixing point to pump outlet, dependent on back pressure (120 $\mu$ l without damper and mixer 600–800 $\mu$ l with damper and mixer)
Materials in contact with mobile phase	
Pump head	SST, gold, sapphire, ceramic
Active Inlet Valve	SST, sapphire, ruby, ceramic, PTFE
Outlet Valve	SST, gold, sapphire, ruby, tantalum
Adapter	SST, gold
Purge Valve	SST, gold, PTFE, ceramic
Damping Unit	Gold, SST

For pump specifications, see “[Site Requirements](#)” on page 26.

## Optimization Features

### What is Pump Elasticity Compensation?

The flow path of the pump consists of pump chambers, sapphire pistons, polymer seals, stainless steel tubing of different dimension, pressure sensor, and so forth. All of these parts deform when pressurized. The sum of this deformation is called pump elasticity. The performance of the pump is greatly enhanced by correcting for this elasticity.

The *Pump Elasticity Calibration* calculates correction factors to compensate for the individual elasticity of the pump that was calibrated. The elasticity is different for every pump and may change with the replacement of parts in the flow path, e.g. pump seals.

All Binary Pumps SL are elasticity calibrated at the factory and require recalibration only after preventive maintenance or major repairs to the flow path. Replacement of capillaries or PTFE frits are not considered a major repair.

### What is Solvent Compressibility Compensation?

Although the compressibility of liquids is orders of magnitude lower than the compressibility of gases, a noticeable volume error is seen when typical chromatographic solvents are compressed to operating pressures as high as 600 bar. In addition, the compressibility changes with pressure, temperature and the amount of dissolved gas. In order to minimize the influence of the latter, the use of a vacuum degasser is mandatory for high precision delivery of liquids. Unfortunately, the influence of the temperature on compressibility is non-linear and cannot be calculated.

The Agilent Binary Pump SL features a new multi point compressibility calibration. The compressibility of a solvent is determined at different pressures from 0 - 600 bar and stored in an XML file. This file can be distributed to other pumps because the solvent compressibility is independent from the pump.

The Binary Pump SL and ChemStation come with predetermined solvent compressibility data for the most common HPLC solvents like water, acetonitrile, methanol, etc. Users can calibrate their own solvent mixtures with the help of an easy to use calibration procedure in the Agilent LC Diagnostic software.

**NOTE**

A correct pump elasticity calibration is an essential prerequisite for successful solvent compressibility calibrations! Solvent compressibility calibrations acquired with a miscalibrated pump will work, but they are not transferable to other pumps!

### How Does Variable Stroke Volume Work?

The smaller the solvent volume in the pump chamber is, the faster it can be recompressed to operating pressure. The Binary Pump SL allows to manually or automatically adjust the pump stroke volume of the first piston in the range of 20 - 100  $\mu$ L. Due to the compression of the solvent volume in the first pump chamber, each piston stroke of the pump will generate a small pressure pulsation, influencing the flow ripple of the pump. The amplitude of the pressure pulsation is mainly dependent on the stroke volume and the compressibility compensation for the solvent in use. Small stroke volumes generate less pressure pulsation than larger stroke volumes at the same flow rate. In addition, the frequency of the pressure pulsation will be higher. This will decrease the influence of flow pulsations on quantitative results.

In gradient mode, smaller stroke volume results in less flow ripple and improves the composition ripple.

The Binary Pump SL uses a processor-controlled ball screw system to drive its pistons. The normal stroke volume is optimized for the selected flow rate. Small flow rates use a small stroke volume while higher flow rates use a higher stroke volume.

The stroke volume for the pump is by default set to AUTO mode. This means that the stroke is optimized for the flow rate in use. A change to larger stroke volumes is possible but not recommended.

## How Does the Binary Pump SL Work?

The solvent from the bottle in the solvent cabinet enters the pump through an active inlet valve. Each side of the Binary Pump SL comprises two substantially identical pump units. Both pump units comprise a ball-screw drive and a pump head with two sapphire pistons for reciprocating movement.

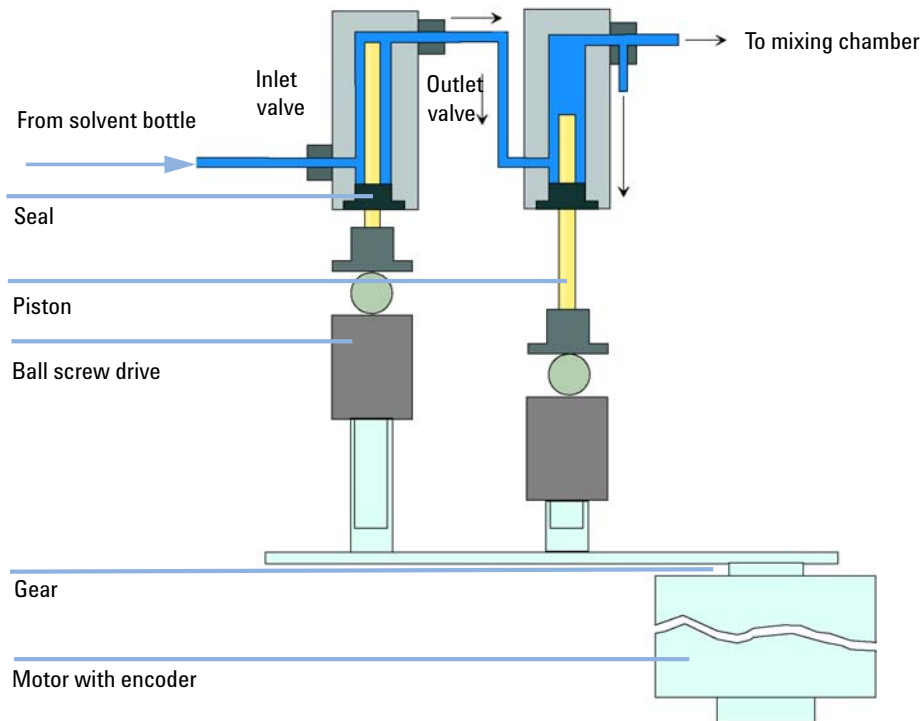

A servo-controlled variable reluctance motor drives the two ball-screw drives in opposite directions. The gears for the ball-screw drives have different circumferences (ratio 2:1) allowing the first piston to move at double the speed of the second piston. The solvent enters the pump heads close to the bottom limit and leaves it at its top. The outer diameter of the piston is smaller than the inner diameter of the pump-head chamber allowing the solvent to fill the gap in between. The first piston has a stroke volume in the range of 20  $\mu\text{l}$  to 100  $\mu\text{l}$  depending on the flow rate. The microprocessor controls all flow rates in a range of 1  $\mu\text{l}/\text{min}$  to 5  $\text{ml}/\text{min}$ . The inlet of the first pumping unit is connected to the active inlet valve which is processor-controlled opened or closed allowing solvent to be drawn into the first pump unit.

The outlet of the first pump chamber is connected by a 500  $\mu\text{L}$  absorber capillary to the second pump chamber. The outlets of the second chambers of both pump channels joined via a small mixing chamber. A coiled restriction capillary connects the mixing chamber via a pressure pulse damper, a mixer and a pressure sensor to the purge valve assembly. The outlet of the purge valve assembly is then connected to the attached chromatographic system.

When turned on, the pump runs through an initialization procedure to determine the upper dead center of the first piston of both pump channels. The first piston moves slowly upwards to the mechanical stop of the pump head and from there it moves back a predetermined path length. The controller stores this piston position in memory. After this initialization the pump starts operation with the set parameters for the two pump channels.

The active inlet valve is opened and the down moving piston draws solvent into the first pump head. At the same time the second piston is moving upwards delivering into the system. After a controller defined stroke length (depending on the flow rate) the drive motors are stopped and the active inlet valve is closed. The motor direction is reversed and moves the first piston up until it reaches the stored upper limit and at the same time moving the second piston downwards.

## 1 Introduction to the Binary Pump SL

### How Does the Binary Pump SL Work?

Then the sequence starts again moving the pistons up and down between the two limits. During the delivery stroke of the first piston the solvent in the pump head is pressed through the outlet ball valve into the second pumping unit. The second piston draws in half of the volume displaced by the first piston and the remaining half volume is directly delivered into the system. During the drawing stroke of the first piston, the second piston delivers the drawn volume into the system.

Delay volume	From mixing point to pump outlet, dependent on back pressure 120 $\mu$ L without damper and mixer 600 – 800 $\mu$ L with damper and mixer
Materials in contact with mobile phase	
Pump head	SST, gold, sapphire, ceramic
Active Inlet Valve	SST, sapphire, ruby, ceramic, PTFE
Outlet Valve	SST, gold, sapphire, ruby, tantalum
Adapter	SST, gold
Purge Valve	SST, gold, PTFE, ceramic
Damping Unit	Gold, SST

For pump specifications, see “[Site Requirements](#)” on page 26.



## What is Pump Elasticity Compensation?

The flow path of the pump consists of pump chambers, sapphire pistons, polymer seals, stainless steel tubing of different dimension, pressure sensor, and so forth. All of these parts deform when pressurized. The sum of this deformation is called pump elasticity.

Let us look at a practical example: Piston 1 draws solvent at ambient pressure. The movement direction is reversed and the piston 1 now compresses the solvent until the operating pressure of the HPLC system is reached. The outlet ball valve opens, and solvent is pumped by piston 1 into pump chamber 2. Due to two factors, the solvent volume that is delivered into the system at high pressure is smaller than it is supposed to be:

- 1 The solvent is compressible
- 2 The pump has a certain elasticity which causes it's internal volume to increase with pressure.

In order to compensate for these two influences, their absolute value must be known.

Since the properties of pure water are very well documented, it's compressibility can be preset. When pumping water, any deviations from the theoretical pressure profile during solvent recompression are caused by the elasticity of the pump.

The *Pump Elasticity Calibration* calculates correction factors to compensate for the individual elasticity of the pump that was calibrated. The elasticity is different for every pump and may change with the replacement of parts in the flow path, e.g. pump seals.

All Binary Pumps SL are elasticity calibrated at the factory and require recalibration only after preventive maintenance or major repairs to the flow path. Replacement of capillaries or PTFE frits are not considered a major repair.

## **How Does Compressibility Compensation Work?**

Although the compressibility of liquids is orders of magnitude lower than the compressibility of gases, a noticeable volume error is seen when typical chromatographic solvents are compressed to operating pressures as high as 600 bar. In addition, the compressibility changes with pressure, temperature and the amount of dissolved gas. In order to minimize the influence of the latter, the use of a vacuum degasser is mandatory for high precision delivery of liquids. Unfortunately, the influence of the temperature on compressibility is non-linear and cannot be calculated.

The Agilent Binary Pump SL features a new multi point compressibility calibration. The compressibility of a solvent is determined at different pressures from 0 - 600 bar and stored in an XML file. This file can be distributed to other pumps because the solvent compressibility is independent from the pump.

The Binary Pump SL and ChemStation come with predetermined solvent compressibility data for the most common HPLC solvents like water, acetonitrile, methanol, etc. Users can calibrate their own solvent mixtures with the help of an easy to use calibration procedure in the Agilent LC Diagnostic software.

Let us use the practical example from the last section once again to understand how compressibility compensation works:

Piston 1 draws solvent at ambient pressure. The movement direction is reversed and piston 1 now compresses the solvent until the operating pressure of the HPLC system is reached. The outlet ball valve opens, and solvent is pumped by piston 1 into pump chamber 2.

Without any compensation, the delivered volume at operating pressure would be too low. In addition, it would take a noticeable amount of time to recompress the solvent to operating pressure. During this time frame, no solvent would be delivered into the system and as a result a high pressure fluctuation (known as *pressure ripple*) would be observed.

When both solvent compressibility at the current operating pressure and pump elasticity are known, the pump can automatically correct for the missing volume by drawing the appropriate larger solvent volume at ambient pressure and speed up the piston during the recompression phase in the first pump chamber. As a result, the pump delivers the accurate volume with any (calibrated) solvent at any pressure at a greatly reduced pressure ripple. For applications that require lowest transition volume of the pump, damper and mixer can be bypassed.

For compatibility with older methods from G1312A binary pumps, the old one-point compressibility compensation is available, too. However, since the compressibility is a non-linear function, one single compressibility value per solvent will only give good results at one particular pressure (which is at 200 bar for the G1312A binary pump)

**CAUTION**

Incorrect pump elasticity calibration.

Solvent compressibility calibrations acquired with a miscalibrated pump will work, but they are not transferable to other pumps. A correct pump elasticity calibration is an essential prerequisite for successful solvent compressibility calibrations.

→ Calibrate the pump elasticity correctly.

---

### **How Does Variable Stroke Volume Work?**

The smaller the solvent volume in the pump chamber is, the faster it can be recompressed to operating pressure. The Binary Pump SL allows to manually or automatically adjust the pump stroke volume of the first piston in the range of 20 - 100  $\mu$ L. Due to the compression of the solvent volume in the first pump chamber, each piston stroke of the pump will generate a small pressure pulsation, influencing the flow ripple of the pump. The amplitude of the pressure pulsation is mainly dependent on the stroke volume and the compressibility compensation for the solvent in use. Small stroke volumes generate less pressure pulsation than larger stroke volumes at the same flow rate. In addition, the frequency of the pressure pulsation will be higher. This will decrease the influence of flow pulsations on quantitative results.

In gradient mode, smaller stroke volume results in less flow ripple and improves the composition ripple.

The Binary Pump SL uses a processor-controlled ball screw system to drive its pistons. The normal stroke volume is optimized for the selected flow rate. Small flow rates use a small stroke volume while higher flow rates use a higher stroke volume.

The stroke volume for the pump is by default set to AUTO mode. This means that the stroke is optimized for the flow rate in use. A change to larger stroke volumes is possible but not recommended.

## Electrical Connections

- The CAN bus is a serial bus with high-speed data transfer. The two connectors for the CAN bus are used for internal Agilent 1200 Series module data transfer and synchronization.
- One analog output provides a pressure signal for integrators or data handling systems.
- The REMOTE connector may be used in combination with other non 1100/1200 Series equipment if you want to use features such as common shut down, prepare, and so on.
- The RS-232 connector may be used to control the Binary Pump SL from a computer via RS-232 connection, using appropriate software. This connector needs to be activated by the configuration switch module at the rear of the pump. The software needs the appropriate drivers to support this communication. See your software documentation for further information.
- The power input socket accepts a line voltage of 100 – 120 or 220 – 240 volts AC  $\pm$  10 % with a line frequency of 50 or 60 Hz. Maximum power consumption is 220 VA (Volt-Amps). There is no voltage selector on your Binary Pump SL because the power supply has wide-ranging capability. There are no externally accessible fuses, because automatic electronic fuses are implemented in the power supply. The security lever at the power input socket prevents that the Binary Pump SL cover is taken off when line power is still connected.
- The interface board slot is used for external contacts, BCD output or the installation of a G1369A LAN interface.

## 1 Introduction to the Binary Pump SL

### Electrical Connections

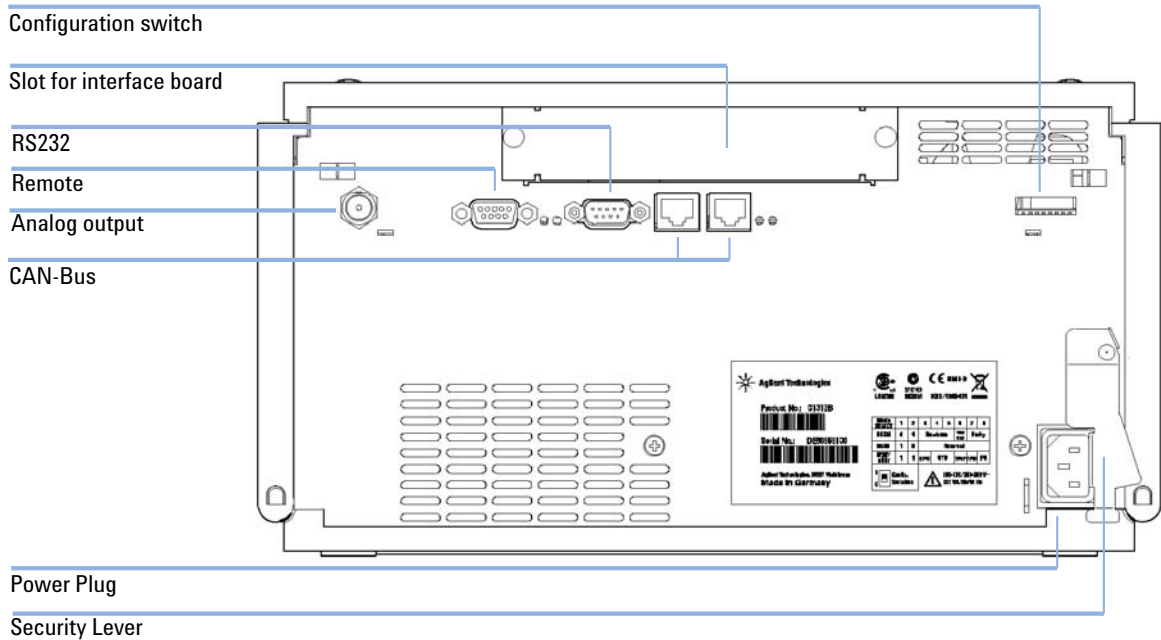

**Figure 3** Electrical Connections to the Binary Pump SL

### Interfaces

The Binary Pump SL provides the following interfaces:

- two CAN connectors as interface to other Agilent 1200 Series modules,
- one RS-232C as interface to a computer,
- one REMOTE connector as interface to other Agilent products,
- one analog output for pressure signal output, and
- one slot for optional interface boards

## The Electronics

The electronics are comprised of four main components:

- The Binary Pump SL main board (CSM), see Service Manual.
- Power supply, see Service Manual.

Optional:

- Interface board (BCD/external contacts), see Service Manual.
- Interface board (LAN), see Service Manual.

## Agilent 1200 Series Interfaces

The Agilent 1200 Series modules provide the following interfaces:

Interface Type	Pumps	Autosampler	DA Detector MW Detector FL Detector	DA Detector MW Detector (G1315C/G1365C)	VW Detector RI Detector	Thermostatted Column Compartment	Vacuum Deg.
CAN	Yes	Yes	Yes	Yes	Yes	Yes	No
LAN (on-board)	No	No	No	Yes	No	No	No
GPIB	Yes**	Yes	Yes	No	Yes	No	No
RS-232C	Yes	Yes	Yes	Yes	Yes	Yes	No
Remote	Yes	Yes	Yes	Yes	Yes	Yes	Yes
Analog	Yes	No	2 ×	2 ×	1 ×	No	Yes <sup>1</sup>
Interface board (LAN/BCD/Ext)	Yes	Yes	Yes	No	Yes	No	No

<sup>1</sup> The vacuum degassers have a special connector for specific use. For details see the degasser manual.\*\*)  
 The G1312B Binary Pump SL does not feature a GPIB connector.

- CAN connectors as interface to other Agilent 1200 Series modules,
- GPIB connector as legacy interface to the Agilent ChemStation,
- RS-232C as interface to a computer,
- REMOTE connector as interface to other Agilent products,
- analog output connector(s) for signal output, and
- interface slot for specific interfacing (external contacts, BCD, LAN, etc.).

For identification and location of the connectors see Figure 6 on page 33.



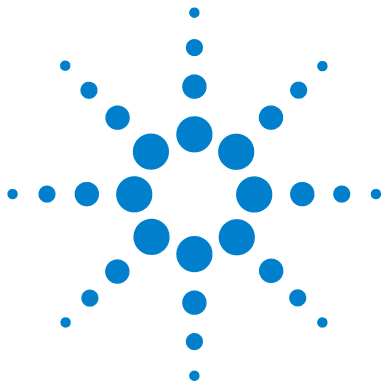

## 2 Site Requirements and Specifications

Site Requirements	26
Power Consideration	26
Power Cords	27
Bench Space	28
Environment	28
Physical Specifications	29
Performance Specifications	30

This chapter provides information about site requirements and specifications for the Binary Pump SL.



## Site Requirements

A suitable environment is important to ensure optimal performance of the pump.

### Power Consideration

The module power supply has wideranging capability (see [Table 2](#) on page 29). It accepts any line voltage in the range described in the above mentioned table. Consequently there is no voltage selector in the rear of the module. There are also no externally accessible fuses, because automatic electronic fuses are implemented in the power supply.

#### **WARNING**

##### **Incorrect line voltage at the instrument**

**Shock hazard or damage of your instrumentation can result, if the devices are connected to a line voltage higher than specified.**

→ Connect your instrument to the specified line voltage.

---

#### **WARNING**

**Module is partially energized when switched off, as long as the power cord is plugged in.**

**Repair work at the module can lead to personal injuries, e.g. shock hazard, when the cover is opened and the module is connected to power.**

→ Remove the power cable from the instrument before opening the cover.

→ Do not connect the power cable to the Instrument while the covers are removed.

---

**CAUTION**

Unaccessible power plug.

In case of emergency it must be possible to disconnect the instrument from the power line at any time.

- Make sure the power connector of the instrument can be easily reached and unplugged.
  - Provide sufficient space behind the power socket of the instrument to unplug the cable.
- 

## Power Cords

Different power cords are offered as options with the module. The female end of all power cords is identical. It plugs into the power-input socket at the rear of the module. The male end of each power cord is different and designed to match the wall socket of a particular country or region.

**WARNING**

**Absence of ground connection or use of unspecified power cord**

**The absence of ground connection or the use of unspecified power cord can lead to electric shock or short circuit.**

- Never operate your instrumentation from a power outlet that has no ground connection.
  - Never use a power cord other than the Agilent Technologies power cord designed for your region.
-

## Bench Space

The module dimensions and weight (see [Table 2](#) on page 29) allow to place the module on almost any laboratory bench. It needs an additional 2.5 cm (1.0 inches) of space on either side and approximately 8 cm (3.1 inches) in the rear for the circulation of air and electric connections.

If the bench should carry a complete Agilent 1200 Series system, make sure that the bench is designed to carry the weight of all the modules.

### NOTE

The module should be operated in a horizontal position!

---

## Environment

Your pump will work within the specifications at ambient temperature and relative humidity described in [Table 2](#) on page 29.

### CAUTION

Condensation within the module

Condensation will damage the system electronics.

- Do not store, ship or use your module under conditions where temperature fluctuations could cause condensation within the module.
  - If your module was shipped in cold weather, leave it in its box and allow it to warm slowly to room temperature to avoid condensation.
- 

### NOTE

The pump is designed to operate in a typical electromagnetic environment (EN61326-1) where RF transmitters, such as mobile phones, should not be used in close proximity.

---

## Physical Specifications

**Table 2** Physical Specifications

Type	Specification	Comments
Weight	15.5 kg (34 lbs)	
Dimensions (width × depth × height)	180 x 345 x 435 mm (7 x 13.5 x 17 inches)	
Line voltage	100 – 240 VAC, ± 10%	Wide-ranging capability
Line frequency	50 or 60 Hz, ± 5%	
Power consumption	220 VA, 74 W / 253 BTU	Maximum
Ambient operating temperature	0–55 °C (32–131 °F)	
Ambient non-operating temperature	-40–70 °C (-4–158 °F)	
Humidity	< 95%, at 25–40 °C (77–104 °F)	Non-condensing
Operating Altitude	Up to 2000 m (6500 ft)	
Non-operating altitude	Up to 4600 m (14950 ft)	For storing the module
Safety standards: IEC, CSA, UL	Installation Category II, Pollution Degree 2	For indoor use only. Research Use Only. Not for use in Diagnostic Procedures.

## Performance Specifications

**Table 3** Performance Specifications of the Agilent 1200 Series Binary Pump SL

Type	Specification	Comments
Hydraulic system	Two dual piston in series pumps with proprietary servo-controlled variable stroke drive, floating piston design and active inlet valve	
Setable flow range	Stipends 0.001 – 5 mL/min, in 0.001 mL/min increments	
Flow range	0.05 – 5.0 mL/min	
Flow precision	? 0.07% RSD or ? 0.02 min SD, whatever is greater	based on retention time at constant room temperature
Flow accuracy	± 1% or 10 µL/min, what ever is greater	measured with water
Pressure	Operating range 0 – 600 bar (0 – 7800 psi) up to 5 ml/min	
Pressure pulsation	<i>Standard delay volume configuration:</i> < 2% amplitude (typically < 1%) <i>Low delay volume configuration:</i> < 5% amplitude (typically < 2%)	at 1 mL/min water, at all pressures > 1 MPa
Compressibility compensation	Automatic, pre-defined, based on mobile phase compressibility	
Recommended pH range	1.0 – 12.5	Solvents with pH < 2.3 should not contain acids which attack stainless steel.
Gradient formation	High-pressure binary mixing	
Delay volume	<i>Standard delay volume configuration:</i> 600-800 µl, dependent on back pressure (includes 400 µl mixer) <i>Low delay volume configuration:</i> 120 µl	measured with water

**Table 3** Performance Specifications of the Agilent 1200 Series Binary Pump SL

Type	Specification	Comments
Composition range	settable range: 0 – 100% recommended range: 1 – 99% or 5 µl/min per channel, whatever is greater	
Composition precision	< 0.15 % RSD	at 1mL/min
Composition accuracy	± 0.35% absolute	(water/caffeine tracer)
Control	Agilent ChemStation for LC (32-bit) G4208A Handheld Controller EZ Chrom Elite	Revision B.02.00 or above
Analog output	For pressure monitoring, 1.33 mV/bar, one output	
Communications	Controller-area network (CAN), RS-232C, APG Remote: ready, start, stop and shut-down signals, LAN optional	
Safety and maintenance	Extensive diagnostics, error detection and display (through Agilent LC Diagnostics), leak detection, safe leak handling, leak output signal for shutdown of pumping system. Low voltages in major maintenance areas.	
GLP features	Early maintenance feedback (EMF) for continuous tracking of instrument usage in terms of seal wear and volume of pumped mobile phase with pre-defined and user-settable limits and feedback messages. Electronic records of maintenance and errors.	
Housing	All materials recyclable.	

**NOTE**

For use with flow rates below 500 µl/min or for use without damper and mixer a vacuum degasser is required.

All specification measurements are done with degassed solvents.

## **2 Site Requirements and Specifications**

### **Performance Specifications**





## 3 Installing the Pump

Unpacking the Binary Pump SL	34
Optimizing the Stack Configuration	36
Installing the Binary Pump SL	43
Flow Connections with Solvent Selection Valve	46
Flow Connections without Solvent Selection Valve	49
Priming the System	52
Initial Priming	52
Regular Priming	54
Changing Solvents	55

This chapter gives information about the preferred stack setup for your system and the installation of your Binary Pump SL.



## Unpacking the Binary Pump SL

### Damaged Packaging

If the delivery packaging shows signs of external damage, please call your Agilent Technologies sales and service office immediately. Inform your service representative that the detector may have been damaged during shipment.

#### CAUTION

"Defective on arrival" problems

If there are signs of damage, please do not attempt to install the module. Inspection by Agilent is required to evaluate if the instrument is in good condition or damaged.

- Notify your Agilent sales and service office about the damage.
  - An Agilent service representative will inspect the instrument at your site and initiate appropriate actions.
-

## Delivery Checklist

Compare the delivery checklist with the contents of the shipping boxes to ensure completeness of the shipment. The contents lists is shown in [Table 4](#) on page 35. For parts identification check the illustrated parts breakdown in “[Parts and Materials for Maintenance](#)” on page 145. Please report missing or damaged parts to your local Agilent Technologies sales and service office.

**Table 4** Binary Pump SL Delivery Checklist

Description	Part Number	Quantity
Binary Pump SL		1
Calibration capillary assembly	<b>G1312-67500</b>	1
Agilent LC Diagnostic CD-ROM	<b>G2173-64000</b>	1
1200 Binary Pump SL Start up Kit	<b>G1312-68700</b>	1
Syringe adapter luer/barb	<b>0100-1681</b>	1
Syringe	<b>9301-0411</b>	1
Solvent cabinet (4 bottles, for pumps with solvent selection valve), <i>or</i> Solvent cabinet (2 bottles, for pumps without solvent selection valve)	<b>5067-1531</b> <b>5067-1532</b>	1
Solvent bottle amber	<b>9301-1450930</b>	1
Solvent bottle transparent	<b>1-1420</b>	1 <i>or</i> 3
Bottle head assembly	<b>G1311-60003</b>	2 <i>or</i> 4
1200 Binary Pump SL User Manual	<b>G1312-90010</b>	1
SB-C18, 2.1x50mm, 1.8um, 600bar, <i>or</i>	<b>827700-902</b>	1, <i>or</i>
SB-C18, 4.6x50mm, 1.8um, 600bar, <i>or</i>	<b>827975-902</b>	1, <i>or</i>
Eclipse XDB-C18, 4.6x50mm, 1.8um, 600bar	<b>927975-902</b>	1
Power cable (matching your country’s power socket)		1
Accessory kit (see <a href="#">Table 22</a> on page 157)	<b>G1312-68725</b>	1

## Optimizing the Stack Configuration

### 1200 RRLC System in Standard Delay Volume Configuration

This configuration is typically used when using 4.6 mm and 3.0 mm ID columns. It is optimized for high flow rates and maximum sensitivity.

For a more detailed help on configuring your instrument, refer to the RRLC Configurator (**part number: 01200-60001**)

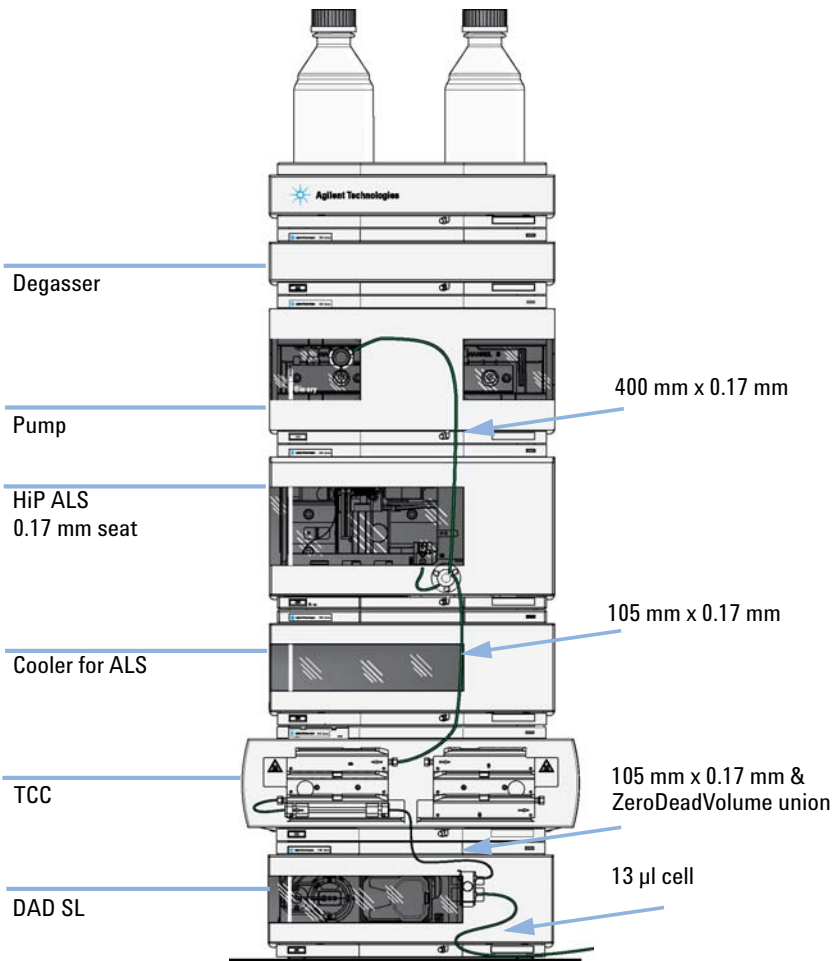
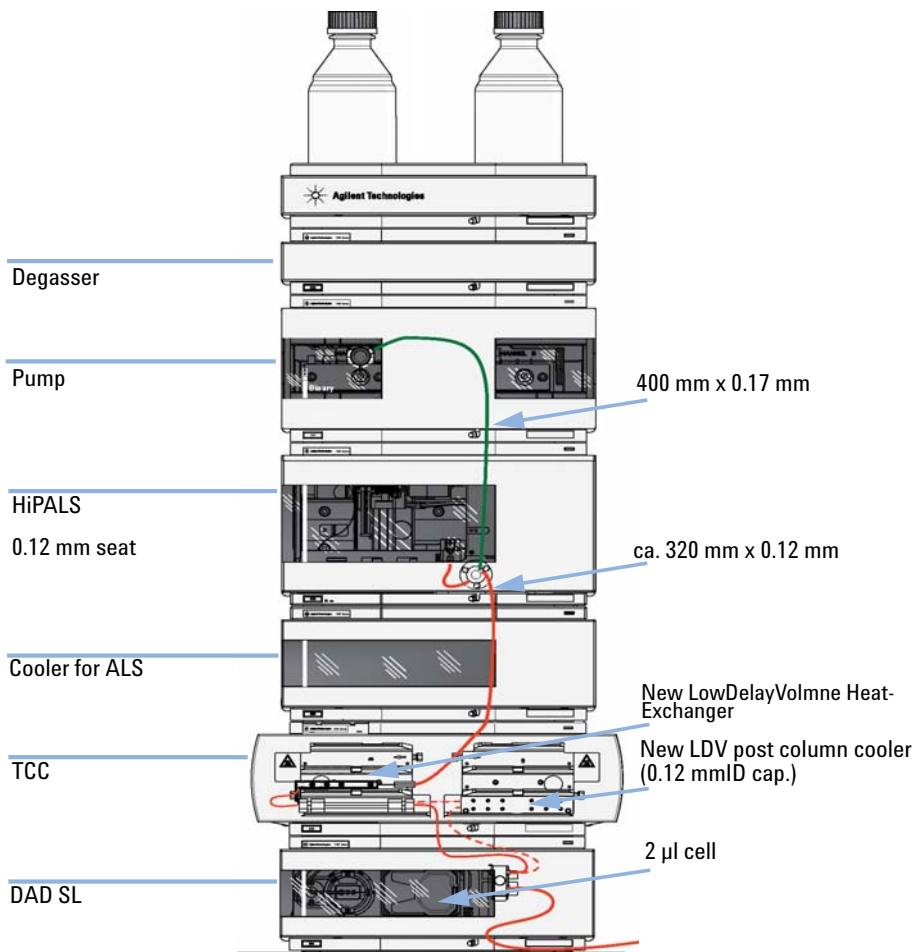

**Figure 4** 1200 RRLC system in standard delay volume configuration for 4.6 mm & 3.0 mm id columns

## 1200 RRLC in Medium Delay Volume Configuration

This setup is used for best Signal to noise ratio using 2.1 mm and 3.0 mm columns.

For a more detailed help on configuring your instrument, refer to the RRLC Configurator (**part number: 01200-60001**)



**Figure 5** 1200 RRLC system in low delay volume configuration for 2.1 mm & 3.0 mm id columns

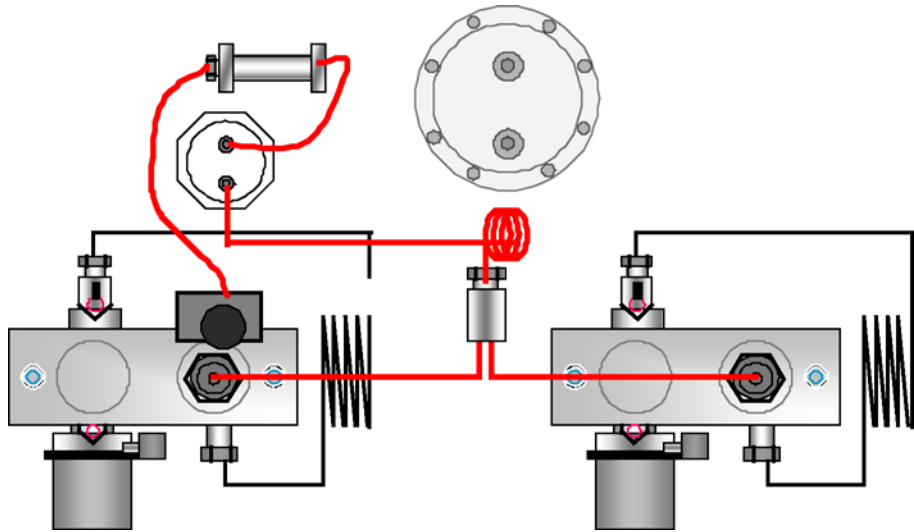
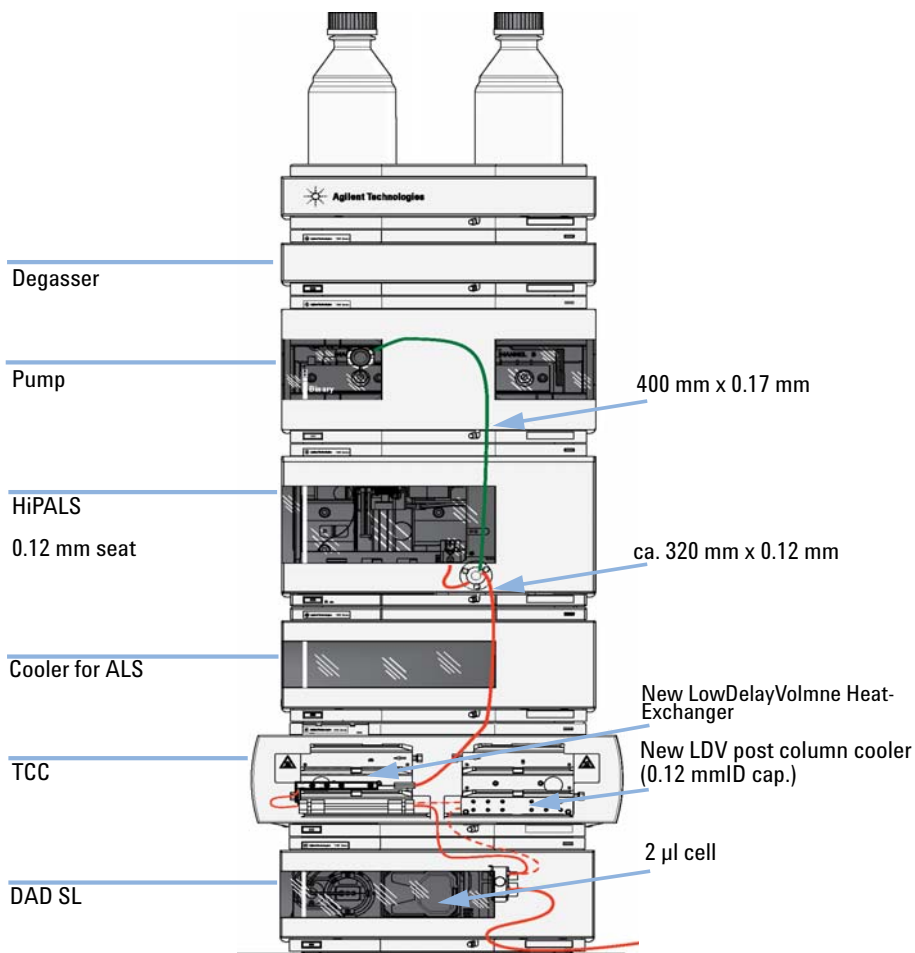

**Figure 6** Binary Pump SL in medium delay volume configuration

## 1200 RRLC in Low Delay Volume Configuration

In this configuration the RRLC is optimized for speed with the 2.1 mm columns.

For a more detailed help on configuring your instrument, refer to the RRLC Configurator (**part number: 01200-60001**)



**Figure 7** 1200 RRLC system in low delay volume configuration for 2.1 mm & 3.0 mm id columns



## 1200 RRLC in Low Delay Volume Configuration with Post Column Cooler

This configuration is usually used for short 2.1 and 3.0 mm columns optimized for high flow rates.

For a more detailed help on configuring your instrument, refer to the RRLC Configurator (**part number: 01200-60001**)

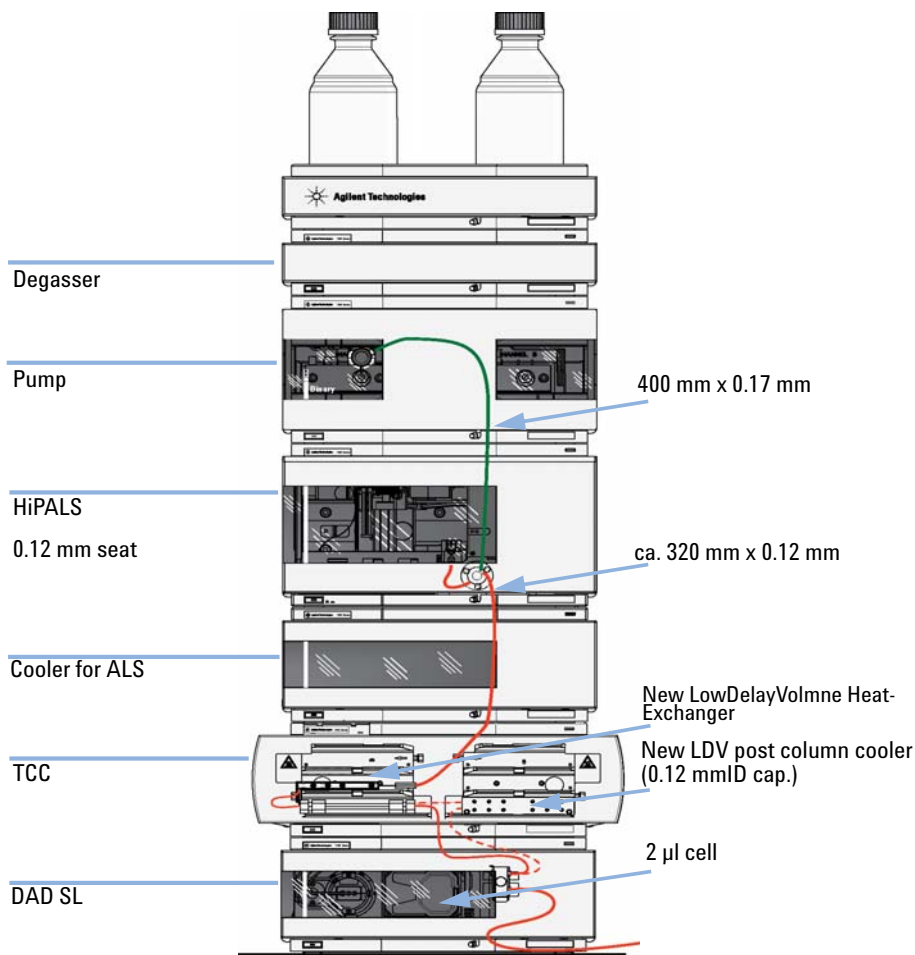
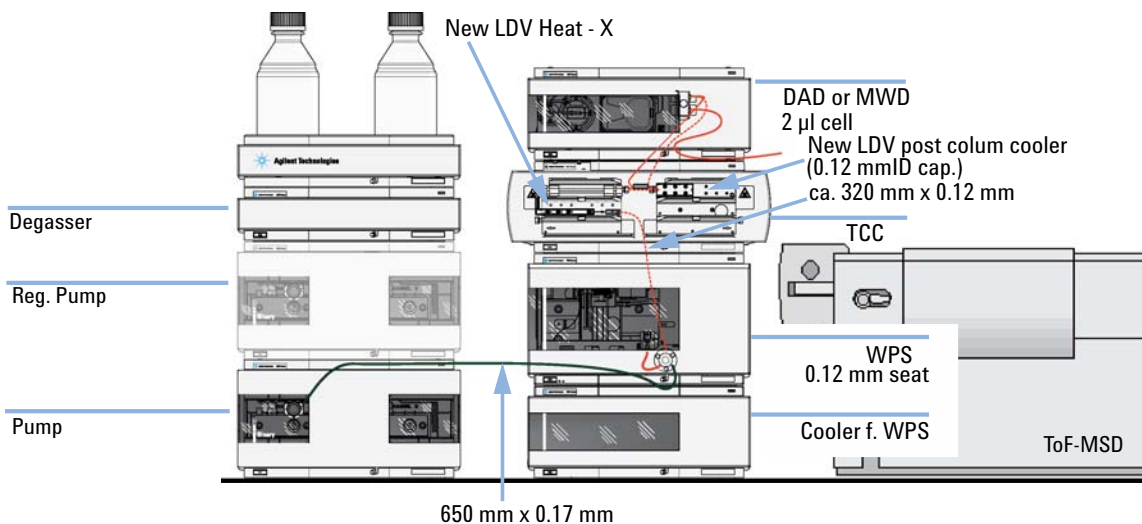

**Figure 8** 1200 RRLC system in low delay volume configuration for 2.1 mm & 3.0 mm id columns

## 1200 RRLC in Low Delay Volume Configuration with Automated Column Regeneration and MS

This is the recommended setup to achieve minimum cycle time using MS detection.

For a more detailed help on configuring your instrument, refer to the RRLC Configurator (**part number: 01200-60001**)

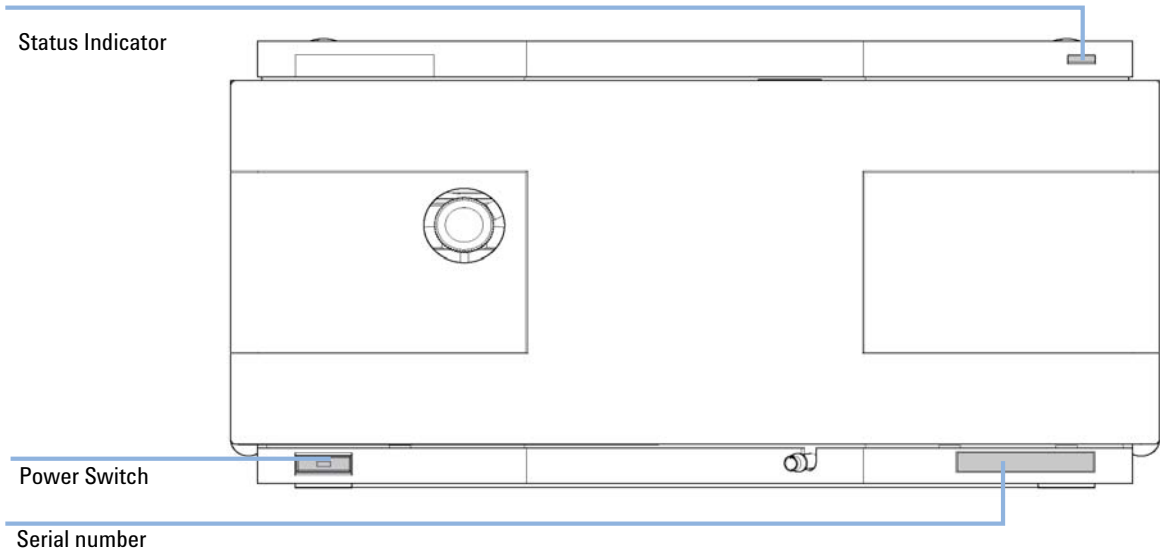

**Figure 9** 1200 RR with Automated column regeneration and TOF in low delay volume configuration

## Installing the Binary Pump SL

Parts required	#	Description
	1	Pump
	1	Power cord, for other cables see text below and <a href="#">“Cable Overview”</a> on page 162
	1	Agilent Control Software and/or Instant Pilot G4208A

- Preparations**
- Locate bench space
  - Provide power connections
  - Unpack the pump
- 1 Place the Pump horizontally on the bench.
  - 2 Ensure the power switch on the front of the pump is OFF (switch stands out).



**Figure 10** Front of Binary Pump SL

- 3 At the rear of the pump turn the security lever to expose the power inlet socket.

### 3 Installing the Pump

#### Installing the Binary Pump SL

- 4 Connect the power cable to the power connector at the back of the Binary Pump SL. The security lever prevents that the cover is opened while the power cord is connected to the pump.
- 5 Connect the required interface cables to the rear of the Binary Pump SL.

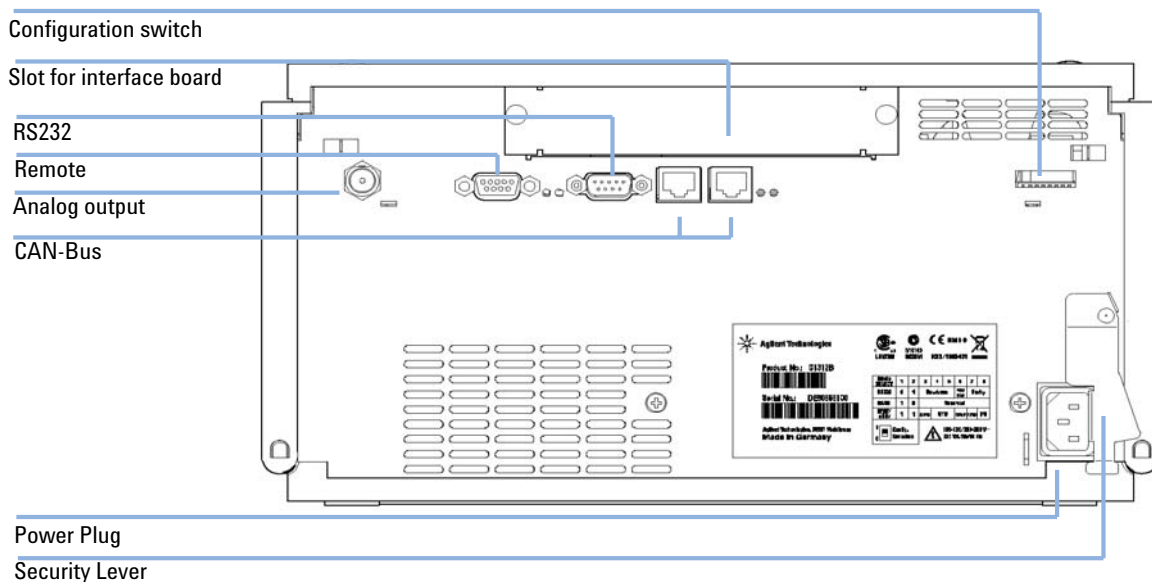

**Figure 11** Rear of the Binary Pump SL

#### NOTE

In an Agilent 1200 Series system, the individual modules are connected through CAN cables. The Agilent 1200 Series vacuum degasser is an exception. It can be connected via APG remote connector to the other modules in the stack. An Agilent 1200 Series Instant Pilot can be connected to the CAN bus at any of the modules in the system except for the degasser. Connection to an Agilent data systems is established through an optional LAN board or the built-in LAN port (DAD SL). Although the LAN board can be installed into all modules except for the degasser and the Thermostatted Column Compartment, the LAN port of the detector should be used as the detector generates the highest data rate of all modules. In case the system comprises a G1315C DAD SL, it is mandatory to connect the data system to the LAN port of the DAD SL. For more information about connecting the Instant Pilot or Agilent Data System refer to the respective user manual. For connecting the Agilent 1200 Series equipment to non-Agilent equipment, see Chapter 15, "Hardware Information" in the Binary Pump SL Service Manual.

- 6 Connect the capillary, solvent tubes and waste tubings (see “[Flow Connections with Solvent Selection Valve](#)” on page 46 or “[Flow Connections without Solvent Selection Valve](#)” on page 49).
- 7 Press the power switch to turn the pump on.

**NOTE**

The power switch stays pressed in and the green indicator LED in the power switch is on while the pump is turned on. When the line power switch stands out and the green light is off, the pump is turned off.

**WARNING**

**Module is partially energized when switched off, as long as the power cord is plugged in.**

**Repair work at the module can lead to personal injuries, e.g. shock hazard, when the cover is opened and the module is connected to power.**

- Make sure that it is always possible to access the power plug.
- Remove the power cable from the instrument before opening the cover.
- Do not connect the power cable to the Instrument while the covers are removed.

- 8 Purge the Binary Pump SL (see “[Initial Priming](#)” on page 52).

The pump is shipped with default configuration settings. To change these settings, refer to the Binary Pump SL Service Manual.

## Flow Connections with Solvent Selection Valve

Parts required	#	Description
	1	Other modules
	1	Parts from accessory kit (see Parts and Materials for Repairs in the Service Manual)
	1	Two wrenches 1/4 - 5/16 inch for capillary connections

**Preparations** Pump is installed in the LC system

### WARNING

**When opening capillary or tube fittings solvents may leak out.**

**The handling of toxic and hazardous solvents and reagents can hold health risks.**

→ Please observe appropriate safety procedures (for example, goggles, safety gloves and protective clothing) as described in the material handling and safety data sheet supplied by the solvent vendor, especially when toxic or hazardous solvents are used.

- 1 Remove the front cover by pressing the snap fasteners on both sides.

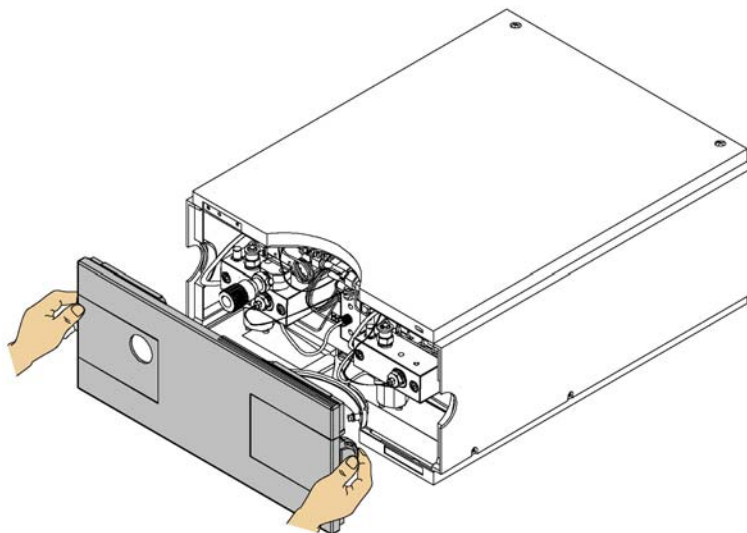

**Figure 12** Removing the Front Cover

- 2 If available, place the online degasser on top of the pump.
- 3 Place the solvent cabinet on top of the Binary Pump SL.
- 4 Set the four bottles into the solvent cabinet and screw a bottle head assembly onto each bottle.
- 5 Connect the solvent tubes from the bottle head assemblies to the inlet connectors A1, A2, B1 and B2 of the solvent selection valve. Make sure to use the brown bottle for the aqueous solvent (usually channel A1).
- 6 Label the tubes accordingly using the supplied stickers and fix the tubes in the clips of solvent cabinet and Binary Pump SL.
- 7 Hold the waste tubing with a piece of sandpaper and push it onto the purge valve outlet. Place the end into your waste system.
- 8 If the Binary Pump SL is not part of an Agilent 1200 Series system stack or placed at the bottom of a stack, connect the corrugated waste tube from the solvent leak drain of the pump to the leak handling system.
- 9 Connect the outlet capillary (pump to injection device) to the 1/4 inch Sawgelok outlet port of the purge valve.

### 3 Installing the Pump

#### Flow Connections with Solvent Selection Valve

**10** Purge your system prior to the first use (see “Initial Priming” on page 52).

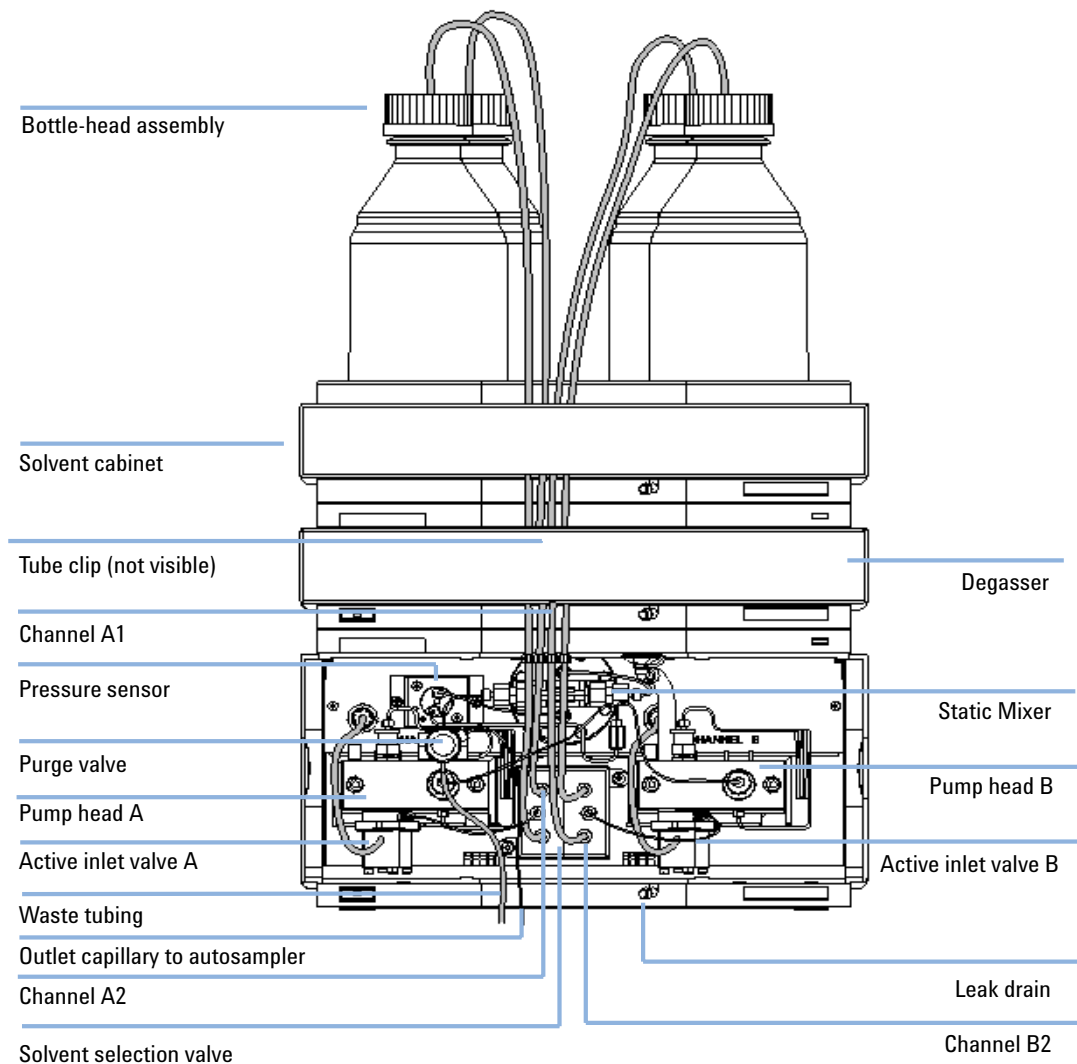

**Figure 13** Binary Pump SL with Solvent Selection Valve



## Flow Connections without Solvent Selection Valve

Parts required	Description
	Other modules
	Parts from accessory kit, see “Accessory Kit G1312-68725” on page 157

**Preparations** Pump is installed in the LC system

### WARNING

**When opening capillary or tube fittings solvents may leak out.**

**The handling of toxic and hazardous solvents and reagents can hold health risks.**

- Please observe appropriate safety procedures (for example, goggles, safety gloves and protective clothing) as described in the material handling and safety data sheet supplied by the solvent vendor, especially when toxic or hazardous solvents are used.

- 1 Remove the front cover by pressing the snap fasteners on both sides.

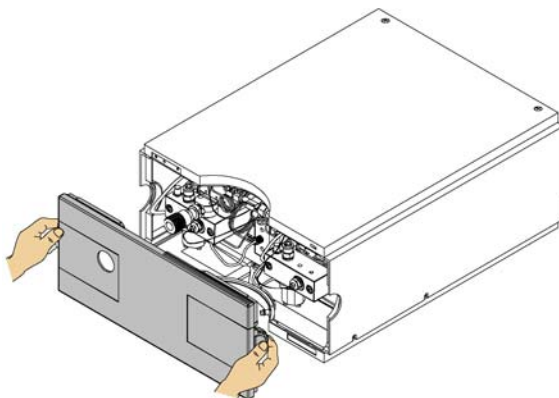

**Figure 14** Removing the Front Cover

- 2 Place the solvent cabinet on top of the Binary Pump SL.
- 3 Place the bottles into the solvent cabinet and place a bottle head assembly into each bottle.

### **3** Installing the Pump

#### Flow Connections without Solvent Selection Valve

- 4** Connect the solvent tubes from the bottle head assemblies to the inlet adapters of the active inlet valves. Fix the tubes in the clips of solvent cabinet and Binary Pump SL.
- 5** Hold the waste tubing with a piece of sandpaper and push it onto the purge valve outlet. Place the end into your waste system.
- 6** If the Binary Pump SL is not part of an Agilent 1200 Series system stack or placed at the bottom of a stack, connect the corrugated waste tube from the solvent leak drain of the pump to the leak handling system.
- 7** Connect the outlet capillary (pump to injection device) to the 1/4 inch Sawgelok outlet port of the purge valve.

8 Purge your system before first use (see “Initial Priming” on page 52)

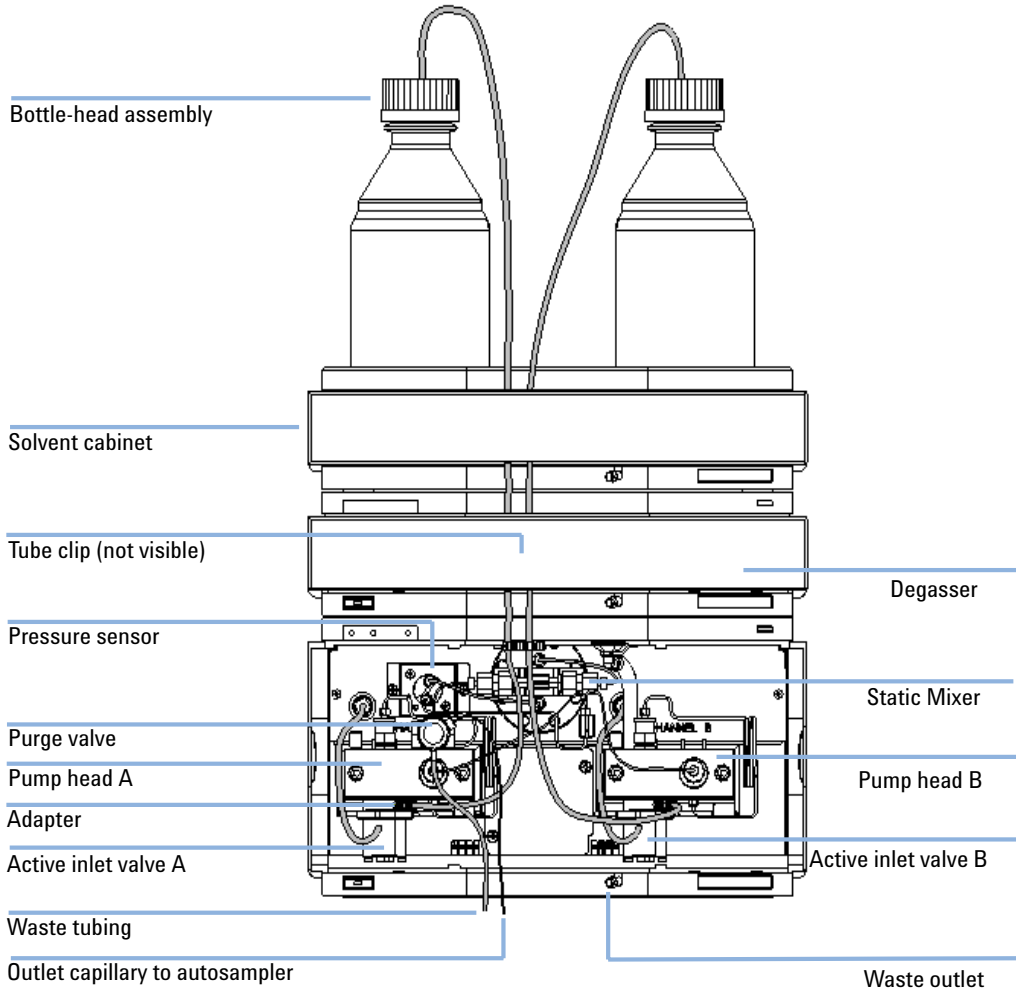

**Figure 15** Flow Connection of Binary Pump SL without Solvent Selection Valve

## Priming the System

### Initial Priming

**When** Before a new degasser or new solvent tubing can be used, it is necessary to prime the system. Isopropanol (IPA) is recommended as priming solvent due to its miscibility with nearly all HPLC solvents and its excellent wetting properties.

**Parts required**

#	Description
1	Isopropanol

**Preparations** Connect all modules hydraulically as described in the respective module manuals.  
Fill each solvent bottle with 100 mL isopropanol  
Switch the system on

#### WARNING

**When opening capillary or tube fittings solvents may leak out.**

**The handling of toxic and hazardous solvents and reagents can hold health risks.**

→ Please observe appropriate safety procedures (for example, goggles, safety gloves and protective clothing) as described in the material handling and safety data sheet supplied by the solvent vendor, especially when toxic or hazardous solvents are used.

#### NOTE

If the pump is not able to aspirate the solvent from the bottles, a syringe can be used to draw the solvent manually through tubing and degasser.

#### NOTE

When priming the vacuum degasser with a syringe, the solvent is drawn through the degasser tubes very quickly. The solvent at the degasser outlet will therefore not be fully degassed. Pump for approximately 10 minutes at your desired flow rate before starting an analysis. This will allow the vacuum degasser to properly degas the solvent in the degasser tubes.

- 1** Open the purge valve of the pump
- 2** Set the flow rate to 5 mL/min.
- 3** Select channel A1
- 4** Turn the flow on
- 5** Observe if the solvent in the tubing of channel A1 is advancing towards the pump. If it isn't, disconnect the solvent tubing from the solvent selection valve, attach a syringe with a syringe adapter and pull the liquid through the degasser. Reattach the tubing to the solvent selection valve.
- 6** Pump 30 mL isopropanol to remove residual air bubbles.
- 7** Switch to the next solvent channel and repeat steps 5 and 6 until all channels have been purged.
- 8** Turn the flow off and close the purge valve.

## Regular Priming

- When** When the pumping system has been turned off for a certain time (for example, overnight) air will rediffuse into the solvent channel between the vacuum degasser and the pump. Solvents containing volatile ingredients will slightly lose these if left in the degasser without flow for a prolonged period of time.
- Preparations** Switch the system on
- 1 Open the purge valve of your pump by turning it counterclockwise and set the flow rate to 5 mL/min.
  - 2 Flush the vacuum degasser and all tubes with at least 10 mL of solvent.
  - 3 Repeat step 1 and 2 for the other channel(s) of the Binary Pump SL.
  - 4 Set the required composition and flow rate for your application and close the purge valve.
  - 5 Pump for approximately 10 minutes before starting your application.

## Changing Solvents

**When** When the solvent of a channel is to be replaced by another solvent that is not compatible (solvents are immiscible or one solvent contains a buffer) it is necessary to follow the procedure below to prevent clogging of the pump by salt precipitation or residual liquid droplets in parts of the system.

**Parts required**

#	Description
1	Purging solvent(s), see <a href="#">Table 5</a> on page 56

**Preparations** Remove the column and replace it by a ZDV fitting.  
Prepare bottles with appropriate intermediate solvents (see [Table 5](#) on page 56)

- 1 If the channel is not filled with a buffer, proceed to step 4.
- 2 Place the solvent intake filter into a bottle of water.
- 3 Flush the channel at a flow rate suitable for the installed tubing (typically 3-5 mL/min) for 10 min.
- 4 Modify the flow path of your system as required for your application. For delay volume optimization see the Rapid Resolution System manual.

### CAUTION

*Buffer salt of aqueous buffers may precipitate in residual isopropanol.*

Capillaries and filter may be clogged by precipitating salt.

→ Don't perform steps 5 to 7 for channels run with aqueous buffer as solvent.

- 5 Replace the solvent bottle by a bottle of isopropanol.
- 6 Flush the channel at a flow rate suitable for the installed tubing (typically 3-5 mL/min) for 5 min.
- 7 Swap the bottle of isopropanol with a bottle of solvent for your application.
- 8 Repeat steps 1 to 7 for the other channel(s) of the Binary Pump SL.
- 9 Install the desired column, set the required composition and flow rate for your application and equilibrate the system for approx. 10 minutes prior to starting a run.

### 3 Installing the Pump

#### Priming the System

**Table 5** Choice of Priming Solvents for Different Purposes

<b>Activity</b>	<b>Solvent</b>	<b>Comments</b>
After an installation	Isopropanol	Best solvent to flush air out of the system
When switching between reverse phase and normal phase (both times)	Isopropanol	Miscible with almost all solvents
After an installation	Ethanol or methanol	Alternative to isopropanol (second choice) if no isopropanol is available
To clean the system when using buffers	HPLC grade water	Best solvent to re-dissolve buffer crystals
After changing aqueous solvents	HPLC grade water	Best solvent to re-dissolve buffer crystals
After the installation of normal phase seals (P/N 0905-1420)	Hexane + 5% isopropanol	Good wetting properties





## 4 Using the Pump

Hints for Successful Use of the Binary Pump SL	58
Setting up the Pump with the G4208A Instant Pilot	60
Setting up the Pump with Agilent ChemStation	61
Overview	61
Setup of Basic Pump Parameters	61
Pump Control	63
Pump Auxiliary Parameters	65
Data Curves	67
Bottle Filling	68
Early Maintenance Feedback (EMF)	70
EMF Counters	71
Using the EMF Counters	72

This chapter explains the operational parameters of the Binary Pump SL.



## Hints for Successful Use of the Binary Pump SL

- Place solvent cabinet with the solvent bottles always on top (or at a higher level) of the Binary Pump SL.
- When using the Binary Pump SL without vacuum degasser, shortly degas your solvents (for example, water vacuum pump for 15 – 30 s in an appropriate vessel) before using them in the pump. If possible apply solvent conditions that will decrease the gas solubility over time (for example, warming up the solvents).
- The use of a vacuum degasser is mandatory for flow rates below 0.5 mL/min and for configurations without damper and mixer.
- When using the binary pump with vacuum degasser, flush the degasser with at least 5 mL per channel before operating the Binary Pump SL, especially when the pumping system had been turned off for a certain length of time (for example, overnight) and volatile solvent mixtures are used in the channels (see “[Regular Priming](#)” on page 54).
- Prevent blocking of solvent inlet filters (never use the pump without solvent inlet filters). Growth of algae should be avoided (see “[Prevent Blocking of Solvent Filters](#)” on page 74).
- Check purge valve frit and column frit in regular time intervals. A blocked purge valve frit can be identified by black, yellow or greenish layers on its surface or by a pressure greater than 10 bar when pumping distilled water at a rate of 5 ml/min with an open purge valve.
- Whenever possible use a minimum flow rate of 5 µl/min per solvent channel to avoid crossflow of solvent into the unused pump channel.
- Whenever exchanging the pump seals, the purge valve frit should be exchanged, too.

- When using buffer solutions, flush the system with water before switching it off. The seal wash option should be used when buffer solutions with concentrations of 0.1 M or higher are being pumped for long periods of time.
- Check the pump plungers for scratches, grooves and dents when changing the piston seals. Damaged plungers cause micro leaks and will decrease the lifetime of the seals.
- After changing the plunger seals, apply the seal wear-in procedure (see [“Exchanging the Pump Seals”](#) on page 124).
- Place the aqueous solvent on channel A and the organic solvent on channel B. The default compressibility settings are set accordingly.

## 4 Using the Pump

### Setting up the Pump with the G4208A Instant Pilot

## Setting up the Pump with the G4208A Instant Pilot

Generic operation of the G4208A Instant Pilot is covered in the Instant Pilot User's Guide, part number G4208-90000. Details about setting up module specific parameters can be found in the Instant Pilot online help.

The pump parameters are described in depth in "[Overview](#)" on page 61.

# Setting up the Pump with Agilent ChemStation

## Overview

Most of these panels can be accessed in two different ways: Pulling down the *Instrument* menu or left-clicking on the icon the GUI.

## Setup of Basic Pump Parameters

The most important parameters of the pump are grouped in the **Set up Pump** panel. Open it either from the Instrument menu or by left-clicking the pump icon in the graphical user interface (GUI).

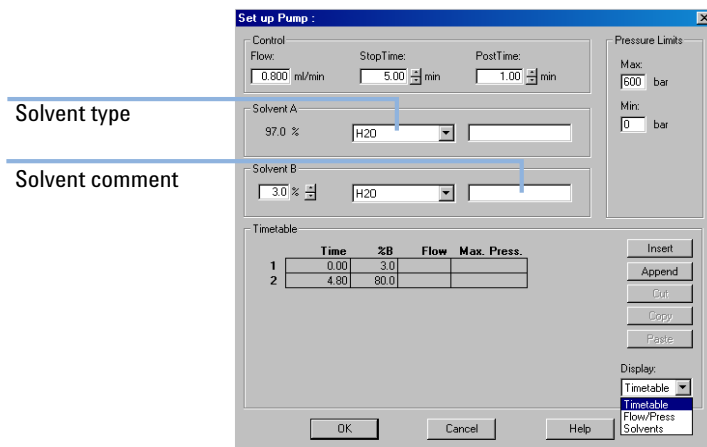

Figure 16 Set up Pump Panel

## 4 Using the Pump

### Setting up the Pump with Agilent ChemStation

**Table 6** Parameters of the Set up Pump Panel

Parameter	Limits	Description
• Flow	0.001 - 5 mL/min	Total flow rate of the pump. See <a href="#">“When to Remove Damper and Mixer”</a> on page 80 for pump hardware modifications to achieve lowest delay volume.
• Stop Time	0.01 min - no limit	The stop time of the pump usually controls the run time of the whole LC system. Use <i>no limit</i> to stop the run manually (useful for method development).
• Post Time	off - 99999 min	Time between the end of a run and the start of the next. Used for column equilibration after a gradient.
• Pressure Limits	Max: 0 - 600 bar Min: 0 - 600 bar	Max must be bigger than Min! Set max pressure to the maximum operating pressure of your column. A min pressure setting of e.g. 10 bar will turn off your pump automatically when running out of solvent. A smarter way, however, is to use the bottle fillings function (see <a href="#">“Bottle Filling”</a> on page 68).
• Solvent A	0 - 100%	Although channel A can be set to 0%, it cannot be turned off. This channel should be used for the aqueous phase (water).
• Solvent B	off - 100%	The percentage of channel B is automatically complemented by channel A to give 100%.
• (Solvent type)	H <sub>2</sub> O, ACN, MeOH, IPA	Select the solvent you are using in the respective solvent channel from the drop-down list. In case your solvent is not listed, perform a solvent compressibility calibration (see <a href="#">“Running the Solvent Compressibility Calibration”</a> on page 104. For details on solvent compressibility see <a href="#">“Binary Pump SL Solvent Calibration”</a> on page 103
• (Solvent Comment)		Free text field for a description of the solvent. This description will show up in method printouts, etc.
• Timetable	max. number of lines depends on free space in pump memory.	Use the timetable to build solvent gradients, flow gradients, or combinations of both. Gradients are always linear. Use multiple timetable entries to mimic exponential or parabolic gradients.
• Display		There are three ways to display the timetable: <ul style="list-style-type: none"> <li>• in tabular form</li> <li>• as flow/pressure graph</li> <li>• as solvent percentage plot</li> </ul> Values can only be changed in tabular view.

## Pump Control

The pump control panel is used to turn the pump on and off, operate the optional seal wash pump and define an error method.

### CAUTION

Upon initialization, the pump ignores the **Maximum Flow Gradient** value (see [Table 7](#) on page 66).

This can result in a rapid and uncontrolled pressure increase.

→ To prevent harm to the column, open the purge valve until the initialization is finished.

---

## 4 Using the Pump

### Setting up the Pump with Agilent ChemStation

- 1 Open menu **Instrument > More Pump > Control** or click on the pump icon in the GUI.

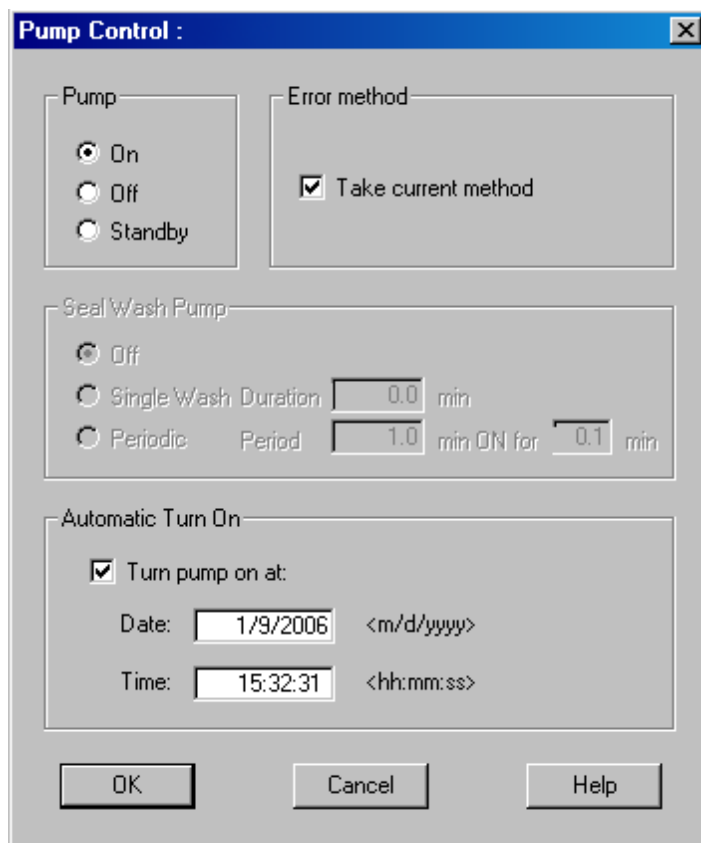

**Figure 17** Pump Control Panel

The pump group enables you to switch the pump **On**, **Off** to **Standby**. In Standby, the pump motor is still energized. When the pump is switched on again, it does not re-initialize.



## Pump Auxiliary Parameters

The parameters in this panel are pre-set to fit most applications. Adjustments should only be made when required. The **Pump Auxiliary** panel can be accessed by the menu via **Instrument > More Pump > Auxiliary** or by left-clicking the pump icon in the GUI.

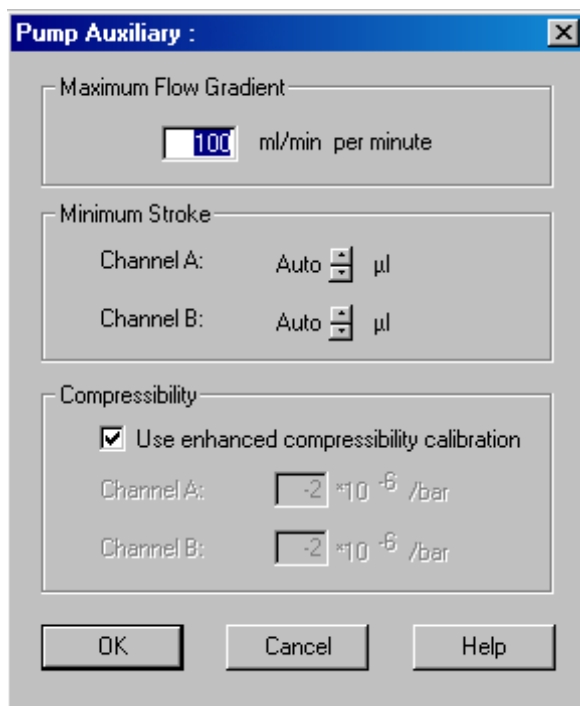

**Figure 18** Pump Auxiliary Parameter Panel

## 4 Using the Pump

### Setting up the Pump with Agilent ChemStation

**Table 7** Parameters of the Pump Auxiliary Panel

Parameter	Limits	Description
• Maximum Flow Gradient	0.1 - 100 mL/min <sup>2</sup> default: 100 mL/min <sup>2</sup>	<p>With this parameter flow rate changes can be ramped up and down slowly to avoid pressure shocks to the column. The default value is 100 ml/min<sup>2</sup> which in fact turns the function off.</p> <p>Caution! The flow is shut off immediately when the pump switched to standby. When the pump is turned <b>On</b> from the <b>Off status</b>, the pump drive initializes, thereby ignoring the maximum flow gradient setting. Depending on system delay volume and flow restriction, the system pressure may rise very quickly to a high value. To protect your column from damage, it is suggested to open the purge valve during initialization.</p>
• Minimum Stroke	20 µL - 100 µL default: Auto	<p>The volume one pump piston delivers per stroke. Generally, a smaller stroke volume results in lower pump ripple. The <b>Auto</b> setting adjusts the strokes dynamically to the lowest possible value.</p> <p>The strokes can be set individually for pump heads A and B.</p>
• Compressibility	0 - 150 E10 <sup>-6</sup> bar or enhanced compressibility calibration default: use enhanced comp. calibration	<p>It is highly recommended to tick the <b>Use enhanced compressibility calibration</b> box. This forces the pump to use either stored solvent compressibility data or user generated compressibility parameters from solvent compressibility calibrations.</p> <p>For legacy support, the solvent compressibility can still be set manually for each channel when the box is unticked.</p>

## Data Curves

The Binary Pump SL provides the possibility to store operational data in the data file of the Agilent data system.

Solvent percentage for each channel, pump flow and pressure are stored when the respective boxes are ticked.

Access the *Data Curves* panel either from the *Instrument - More Pump - Data Curves* menu or by left-clicking the pump icon in the GUI.

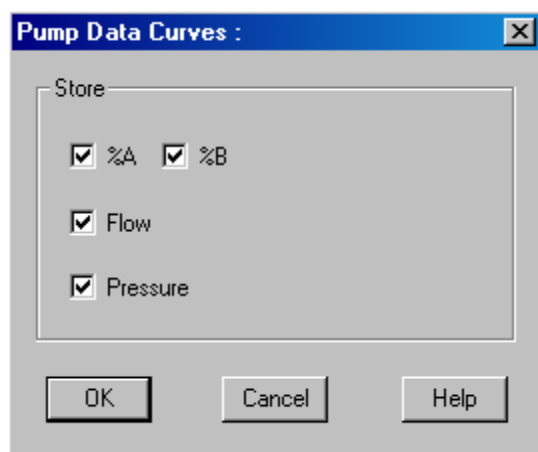

**Figure 19** Data Curves Panel

### NOTE

The pressure data curve is *generated* from the pressure sensor readings, while %A, %B and flow are *calculated* from the method settings of the pump.

## Bottle Filling

The pump offers a powerful feature to monitor the liquid level in the solvent bottles. With total bottle volume and initial filling volume set correctly, the pump subtracts the displaced volume continuously from the initial value and reacts before the system runs dry or an analysis is corrupted.

### CAUTION

The bottle filling feature will fail if multiple channels are fed from one solvent bottle!

→ In that case implement a minimum pressure limit (see [Table 6](#) on page 62) to avoid that the Binary Pump SL runs dry when solvents are empty.

- 1 Open menu **Instrument/More Pump/ Bottle Filling** or click on the solvent bottles below the pump icon in the GUI.

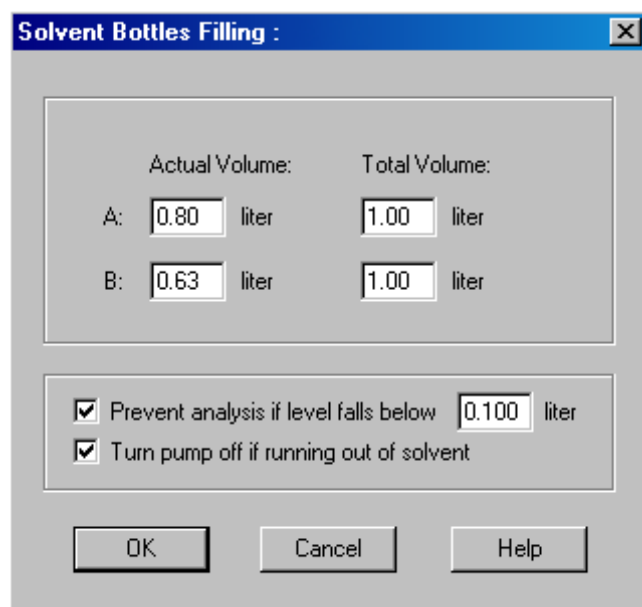

Figure 20 Bottle Filling Panel

**Table 8** Bottle Filling Parameters

Parameter	Limits	Description
• Total Volume	0 - 1000 L <small>default: 0 L</small>	Enter the total capacity of the solvent vessel in this box. Mind that the dimension is Liters!
• Actual Volume	0 - 1000 L <small>default: 0 L</small>	After filling the solvent bottles, enter the actual volumes into these boxes. The actual volume must not be larger than the total volume of the bottle.
• Prevent analysis.....	<small>default: turned off</small>	When ticked, the pump won't start a new run if the solvent level in one or more bottles is below the given value. When setting this parameter, consider the size and shape of the solvent vessel and make sure the pump does not draw air when coming close to the limit.
• Turn pump off...	<small>default: turned off</small>	When ticked, the pump will turn off before air is aspirated. However, the residual solvent volume has been calculated for 1 L solvent bottles and may be too small for large bottles or other vessels.

## Early Maintenance Feedback (EMF)

Maintenance requires the exchange of components in the flow path which are subject to mechanical wear or stress. Ideally, the frequency at which components are exchanged should be based on the intensity of usage of the instrument and the analytical conditions, and not on a predefined time interval. The early maintenance feedback (EMF) feature monitors the usage of specific components in the instrument, and provides feedback when the user-settable limits have been exceeded. The visual feedback in the user interface provides an indication that maintenance procedures should be scheduled.

## EMF Counters

The binary pump provides a series of EMF counters for the left and right pump heads. Each counter increments with pump use, and can be assigned a maximum limit which provides visual feedback in the user interface when the limit is exceeded. Each counter can be reset to zero after maintenance has been done. The binary pump provides the following EMF counters:

- liquimeter pump A,
- seal wear pump A,
- liquimeter pump B, and
- seal wear pump B.

### Liquimeters

The liquimeters display the total volume of solvent pumped by the left and right pump heads since the last reset of the counters. Both liquimeters can be assigned an EMF (maximum) limit. When the limit is exceeded, the EMF flag in the user interface is displayed.

### Seal Wear Counters

The seal wear counters display a value derived from pressure and flow (both contribute to seal wear). The values increment with pump usage until the counters are reset after seal maintenance. Both seal wear counters can be assigned an EMF (maximum) limit. When the limit is exceeded, the EMF flag in the user interface is displayed.

## Using the EMF Counters

The user-settable EMF limits for the EMF counters enable the early maintenance feedback to be adapted to specific user requirements. The wear of pump components is dependent on the analytical conditions, therefore, the definition of the maximum limits need to be determined based on the specific operating conditions of the instrument.

### Setting the EMF Limits

The setting of the EMF limits must be optimized over one or two maintenance cycles. Note the pumped volumes and the seal wear values of both pump heads when symptoms of excessive seal wear are observed. Perform pump maintenance and enter the noted EMF values minus a safety margin of 10% as new EMF limits. Reset the EMF counters to zero. The next time the EMF counters exceed the new EMF limits, the EMF flag will be displayed at the appropriate time, providing a reminder that maintenance needs to be scheduled



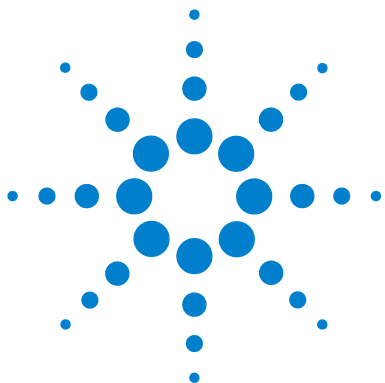

## 5 Optimizing Performance

Prevent Blocking of Solvent Filters	74
Checking the Solvent Filters	75
Cleaning the Solvent Filters	75
When to Use a Vacuum Degasser	76
Operational Hints for the Vacuum Degasser	76
When to Use the Active Seal Wash Option	77
When to Use Alternative Seals	78
When to Use the Low volume mixer	79
When to Remove Damper and Mixer	80
Convert the Binary Pump SL to Low Delay Volume Mode	81
How to Optimize the Compressibility Compensation Setting	83
Solvent Compressibility Calibration	83
Optimization of Legacy Compressibility Settings	84

This chapter gives information on how to optimize the performance of the Binary Pump SL under special operational conditions.



## Prevent Blocking of Solvent Filters

Contaminated solvents or algae growth in the solvent bottle will reduce the lifetime of the solvent filter and will influence the performance of the Binary Pump SL. This is especially true for aqueous solvents or phosphate buffers (pH 4 to 7). The following suggestions will prolong lifetime of the solvent filters and maintain the performance of the Binary Pump SL.

- Use a sterile, if possible amber, solvent bottle to slow down algae growth.
- Filter solvents through filters or membranes that remove algae.
- Exchange aqueous solvents every two days or refilter.
- If the application permits, add 0.0001 to 0.001 Molar sodium azide to the solvent.
- Place a layer of argon on top of your solvent.
- Avoid exposure of the solvent bottles to direct sunlight.

## Checking the Solvent Filters

The solvent filters are located on the low-pressure side of the Binary Pump SL. A blocked filter therefore does not necessarily affect the high pressure readings of the pump. The pressure readings cannot be used to check whether the filters are blocked or not. If the solvent cabinet is placed on top of the Binary Pump SL, the filter condition can be checked in the following way:

Remove the solvent inlet tube from the inlet port of the solvent selection valve or the adapter at the active inlet valve. If the filter is in good condition, the solvent will freely drip out of the solvent tube (due to hydrostatic pressure). If the solvent filter is partly blocked only very little solvent will drip out of the solvent tube.

### WARNING

**When opening capillary or tube fittings solvents may leak out.**

**The handling of toxic and hazardous solvents and reagents can hold health risks.**

→ Please observe appropriate safety procedures (for example, goggles, safety gloves and protective clothing) as described in the material handling and safety data sheet supplied by the solvent vendor, especially when toxic or hazardous solvents are used.

---

## Cleaning the Solvent Filters

- Remove the blocked solvent filter from the bottle-head assembly and place it in a beaker with concentrated nitric acid (35%) for one hour.
- Thoroughly flush the filter with HPLC-grade water (remove all nitric acid, some capillary columns can be damaged by nitric acid).
- Replace the filter.

### NOTE

Never use the system without solvent filter installed.

---

## When to Use a Vacuum Degasser

The Binary Pump SL does not necessarily require degassing. However, for the following conditions a vacuum degasser is mandatory:

- Your detector is used with maximum sensitivity in the low UV wavelength range,
- Your application requires highest injection precision, or
- Your application requires highest retention-time reproducibility (flow rates below 0.5 mL/min).
- The Binary Pump SL is used with bypassed damper and mixer.

### Operational Hints for the Vacuum Degasser

If you are using the vacuum degasser for the first time, if the vacuum degasser was switched off for any length of time (for example, overnight), or if the vacuum degasser chambers are empty, you have to prime the vacuum degasser before running an analysis. Priming is usually done by pumping at a high flow rate (3 - 5 mL/min). Alternatively, a syringe can be used to draw the solvent through the (empty) degasser if the pump does not aspirate the solvent by itself. For details see “[Initial Priming](#)” on page 52.

For more information see the *Manual* of the Agilent 1200 Series vacuum degasser.

## When to Use the Active Seal Wash Option

Concentrated buffer solutions will reduce the lifetime of the seals and plungers in your Binary Pump SL. The active seal wash option allows to maintain the seal lifetime by flushing the low pressure side of the seals with a wash solvent.

The seal wash option is strongly recommended if buffer concentrations of 0.1 M or higher are used regularly with the Binary Pump SL.

The active seal wash option kit can be ordered by quoting part number G1312-68712.

The seal wash option comprises a peristaltic pump, secondary seals, gaskets, seal keepers and tubing for both pump heads. A bottle of premixed water/isopropanol (90/10 vol%) is placed in the solvent cabinet and connected to the peristaltic pump as described in the technical note that comes with the active seal wash kit.

Always use a mixture of HPLC-water (90 %) and isopropanol (10 %) as wash solvent. This mixture prevents bacteria growth in the wash bottle and reduces the surface tension of the water.

The operation of the peristaltic pump can be controlled from the data system or the Instant Pilot.

### NOTE

The Binary Pump SL comes with pre-installed seal wash capable support rings. When the user decides to use seal wash it is recommended to replace the secondary seals and gaskets by new ones to ensure tightness.

For information on the installation of the continuous seal wash option refer to Installing the Active Seal Wash Option in the *Service Manual*.

## When to Use Alternative Seals

The standard seals for the Binary Pump SL can be used for most applications. However, normal phase applications (for example, hexane) are not compatible with the standard seals. They cause extremely high abrasion and significantly shorten seal life time.

For the use with normal phase applications special polyethylene pistons seals (yellow color), part number 0905-1420 (pack of 2) are available. These seals have less abrasion compared to the standard seals.

### **WARNING**

**The seal wear-in procedure causes problems to the normal phase seals (yellow). They will be destroyed by the procedure.**

→ DO NOT apply the seal wear-in procedure performed to normal phase seals.

---

- 1 Remove the standard seals from the pump head (“[Exchanging the Pump Seals](#)” on page 124).
- 2 Install normal phase seals.

### **NOTE**

Polyethylene seals have a limited pressure range of 0–200 bar. When used above 200 bar, their lifetime will be significantly reduced.

---

## When to Use the Low volume mixer

The low volume mixer is designed for use with the Rapid Resolution LC system in low delay volume mode. This configuration is typically used for 2.1 mm ID, 1.8 $\mu$ m particle size columns, where emphasis is put on S/N ratio. The low volume mixer helps mixing gradients starting with a low concentration of organic solvents, which can cause noise on the baseline. The maximum benefit of the mixer is achieved using the mixer together with FW revisions A.06.06 or higher.

## When to Remove Damper and Mixer

The Binary Pump SL is equipped with a pressure pulsation damper and a static mixer. The total delay volume of the pump is 600 – 800  $\mu\text{L}$  (depending on system pressure). The mixer has a volume of 400  $\mu\text{L}$ .

For applications that require lowest delay volume (e.g. fast gradient methods or gradient applications with low flow rates), damper and mixer can be bypassed.

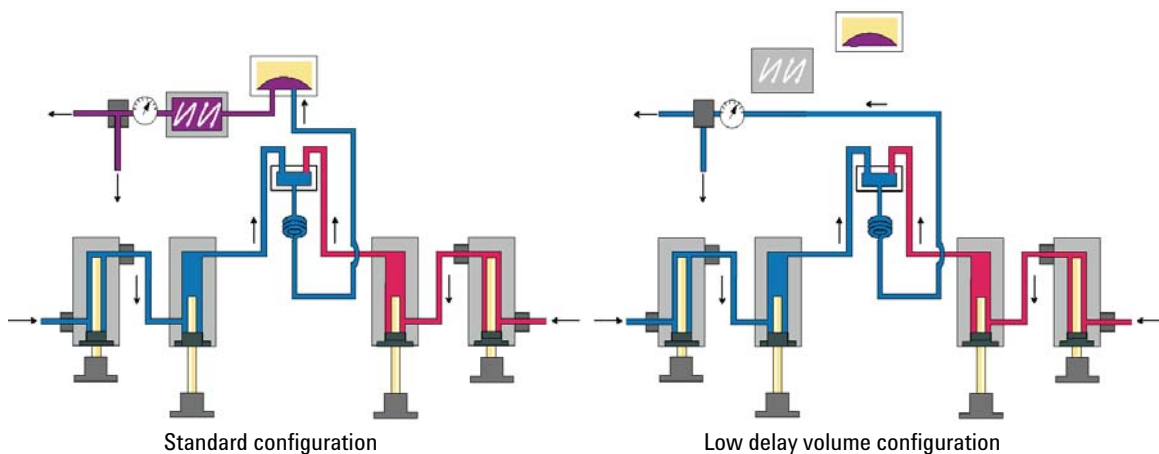

**Figure 21** Flow Path Modifications of the Binary Pump SL



## Convert the Binary Pump SL to Low Delay Volume Mode

The Binary Pump SL is delivered in standard configuration (damper and mixer connected). This paragraph shows how to bypass damper and mixer and convert the pump to low delay volume mode.

Configurations where only damper or mixer are disconnected while the other part is still in line are not supported by Agilent Technologies.

**Tools required** Wrench 1/4 – 5/16 inch, part no. **8710-0510**  
Wrench, 14 mm, part no. 8710-1924  
Hex driver open, 1/4 inch, part no. 5023-0240

**Preparations** Flush the system (water if buffers were used, otherwise IPA).  
Turn the flow off.

**1** Remove the front cover by pressing the clip fastener on both sides of the cover.

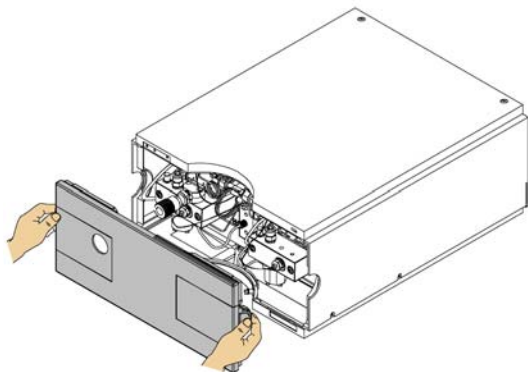

**2** Use the 1/4 inch hex driver to remove fitting *B* from port 2 of the pressure sensor.

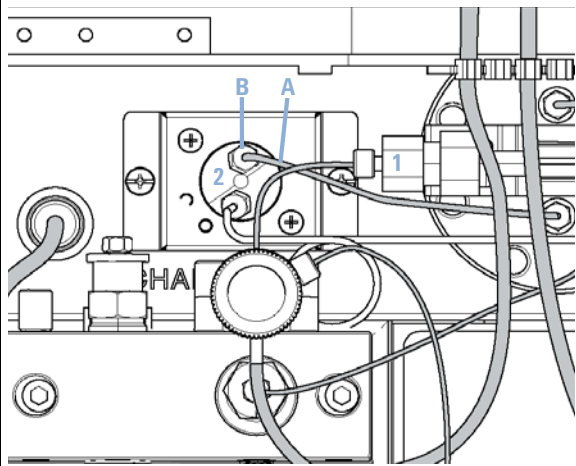

## 5 Optimizing Performance

### When to Remove Damper and Mixer

- 3** Fold capillary end *B* away. It remains unconnected. Disconnect fitting *A* from outlet *1* of the mixer.

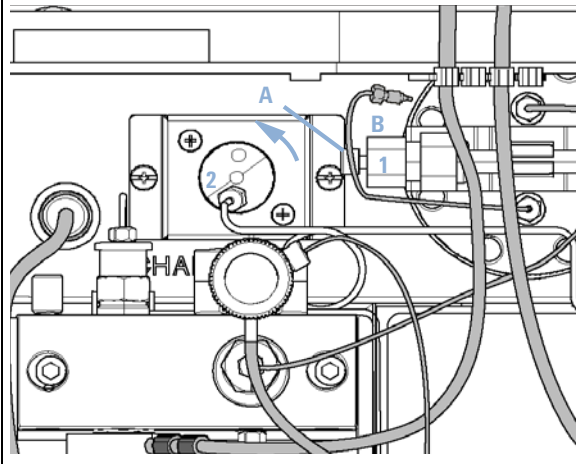

- 4** Connect fitting *A* to port 2 of the pressure sensor. Seal port *1* of the mixer with a plastic blank nut.

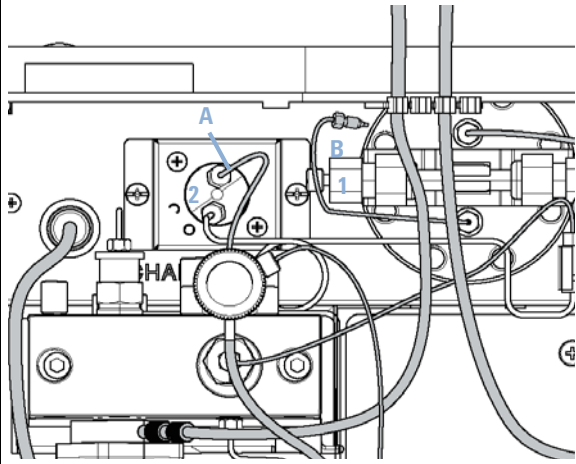

## How to Optimize the Compressibility Compensation Setting

When a solvent is metered at ambient pressure and compressed to a higher pressure, the volume decreases. This is due to an effect known as solvent compressibility. Solvent compressibility is a non-linear function of pressure and temperature. It is unique to every solvent.

In order to deliver the desired flow accurately at all pressures, Agilent pumps use a compressibility compensation. Usually, an average compressibility value for the solvent is used across the whole pressure range of the pump.

The G1312B Binary Pump SL introduces a new compressibility compensation concept. The compressibility of a solvent is determined at different pressures between 0 to 600 bar. The pump uses the obtained non-linear function to select the correct compressibility value for the actual pump pressure.

Compressibility data for the most common solvents is readily available in the pump firmware.

The compensation algorithm is so powerful that the damper and mixer can be removed from the pump flow path at low flow rate while the pressure ripple and composition ripple remain at low levels.

For method compatibility reasons, the legacy compressibility compensation is still available.

### Solvent Compressibility Calibration

Unlisted or premixed solvents can be calibrated with the Solvent Compressibility Calibration function. For a detailed description, see [“Binary Pump SL Solvent Calibration”](#) on page 103.

## Optimization of Legacy Compressibility Settings

The compressibility compensation default settings are  $50 \times 10^{-6}$  /bar (best for most aqueous solutions) for pump head A and  $115 \times 10^{-6}$  /bar (to suit organic solvents) for pump head B. The settings represent average values for aqueous solvents (A side) and organic solvents (B side). Therefore it is always recommended to use the aqueous solvent on the A side of the pump and the organic solvent on the B side. Under normal conditions, the default settings reduce the pressure pulsation to below 2 % of system pressure, which is sufficient for most applications. If the compressibility values for the solvents used differ from the default settings, it is recommended to change the compressibility values accordingly. Compressibility settings can be optimized by using the values for various solvents described in [Table 9](#) on page 85. If the solvent in use is not listed in the compressibility table, when using premixed solvents and if the default settings are not sufficient for your application, the following procedure can be used to optimize the compressibility settings:

- 1 Start channel A of the Binary Pump SL with the required flow rate.
- 2 Before starting the optimization procedure, the flow must be stable. Use degassed solvent only. Check the tightness of the system with the pressure test (see [“Pressure Test Description”](#) on page 96).
- 3 Your pump must be connected to a Chemstation or Instant Pilot, the pressure- and %-ripple can be monitored with one of these instruments, otherwise connect a signal cable between the pressure output of the isocratic pump and a recording device (for example, 339X integrator) and set following parameters.  
Zero 50 % Att 2<sup>3</sup> Chart Speed 10 cm/min
- 4 Start the recording device in plot mode.
- 5 Starting with a compressibility setting of  $10 \times 10^{-6}$  /bar, increase the value in steps of 10. Re-zero the integrator as required. The compressibility compensation setting that generates the smallest pressure ripple is the optimum value for your solvent composition.
- 6 Repeat step 1 through step 5 for the B channel of your Binary Pump SL.

**Table 9** Solvent Compressibility

<b>Solvent (pure)</b>	<b>Compressibility (<math>10^{-6}</math>/bar)</b>
Acetone	126
Acetonitrile	115
Benzene	95
Carbon tetrachloride	110
Chloroform	100
Cyclohexane	118
Ethanol	114
Ethyl acetate	104
Heptane	120
Hexane	150
Isobutanol	100
Isopropanol	100
Methanol	120
1-Propanol	100
Toluene	87
Water	46

## **5 Optimizing Performance**

### **How to Optimize the Compressibility Compensation Setting**



## 6 Troubleshooting and Diagnostics

Overview of the Pump's Indicators and Test Functions	88
Status Indicators	90
Power Supply Indicator	90
Status Indicator	91
User Interfaces	92
Agilent Lab Advisor software	93

Overview of the troubleshooting and diagnostic features.



## Overview of the Pump's Indicators and Test Functions

### Status Indicators

The pump is provided with two status indicators which indicate the operational state (pre-run, run, and error states) of the module. The status indicators provide a quick visual check of the operational status of the pump (see [“Status Indicator”](#) on page 91).

### Error Messages

In the event of an electronic, mechanical or hydraulic failure, the Binary Pump SL generates an error message in the user interface. For each message, a short description of the failure, a list of probable causes of the problem, and a list of suggested actions to fix the problem are provided (see Service Manual).

### Test Functions

A series of test functions are available for troubleshooting and operational verification after exchanging internal components (see [“Tests and Calibration Functions”](#) on page 95).

### Compressibility Calibration

Solvent compressibility is a function of solvent type and pressure. In order to optimize flow accuracy and pressure ripple, the compressibility of the solvent must be considered. The Binary Pump SL firmware contains compressibility parameters for most commonly used solvents. A compressibility calibration function is available to generate compressibility data for unlisted solvents (see [“Binary Pump SL Solvent Calibration”](#) on page 103). The compressibility data are stored in an XML file and can be transferred to other G1312B pumps.



## Elasticity Calibration

Various parts in the flow path of the Binary Pump SL have a certain elasticity which needs to be compensated for to obtain the lowest pressure-, flow- and composition ripple possible. This is done by running an elasticity calibration after maintenance and major repairs. For details see Service Manual

## Diagnostic Signals

The pump has several signals (pressure, voltages and piston movement) that can be used for diagnosing pressure stability, composition and flow problems (see [“Diagnostic Signals”](#) on page 105).

## Status Indicators

Two status indicators are located on the front of the Binary Pump SL. The lower left indicates the power supply status, the upper right indicates the operational status.

### Power Supply Indicator

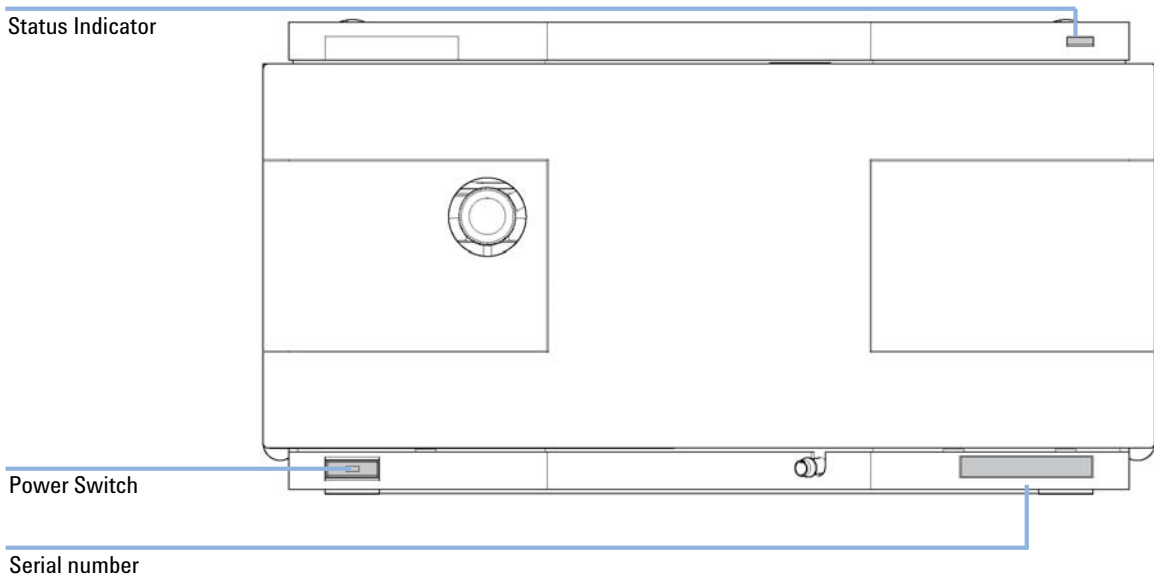

The power supply indicator is embedded into the main power switch. When the indicator is illuminated (*green*) the power is ON.

## Status Indicator

The pump status indicator indicates one of four possible instrument conditions:

- When the status indicator is OFF (and power switch light is on), the pump is in a *prerun* condition, and is ready to begin an analysis.
- A *green* status indicator indicates the pump is performing an analysis (*run* mode).
- A *yellow* indicator indicates a *not-ready* condition. The pump is in a not-ready state when it is waiting for a specific condition to be reached or completed (for example, immediately after changing a set point), or during initialization.
- An *error* condition is indicated when the status indicator is *red*. An error condition indicates the pump has detected an internal problem which compromises correct operation of the pump. Usually, an error condition requires attention (e.g. leak, defective internal components). An error condition always interrupts the analysis.
- A *red-blinking* indicator indicates that the module is in resident mode (e.g. during update of main firmware).

## User Interfaces

Depending on the user interface, the available tests vary. Some descriptions are only available in the Service Manual.

Test	ChemStation	Instant Pilot G4208A	Agilent LC Diagnostic Software
Pressure Test	No	Yes	Yes
Pump Test	No	No	Yes
Solvent compressibility calibration	No	No	Yes
Pump elasticity calibration	No	No	Yes

**NOTE**

The Agilent Control Module (G1323B) cannot be used with the G1312B pump!

## Agilent Lab Advisor software

The Agilent Lab Advisor software is a standalone product that can be used with or without data system. Agilent Lab Advisor software helps to manage the lab for high quality chromatographic results and can monitor in real time a single Agilent LC or all the Agilent GCs and LCs configured on the lab intranet.

Agilent Lab Advisor software provides diagnostic capabilities for all Agilent 1200 Series HPLC modules. This includes diagnostic capabilities, calibration procedures and maintenance routines for all the maintenance routines.

The Agilent Lab Advisor software also allows users to monitor the status of their LC instruments. The Early Maintenance Feedback (EMF) feature helps to carry out preventive maintenance. In addition, users can generate a status report for each individual LC instrument. The tests and diagnostic features as provided by the Agilent Lab Advisor software may differ from the descriptions in this manual. For details refer to the Agilent Lab Advisor software help files.

This manual provides lists with the names of Error Messages, Not Ready messages, and other common issues.

**6 Troubleshooting and Diagnostics**  
Agilent Lab Advisor software

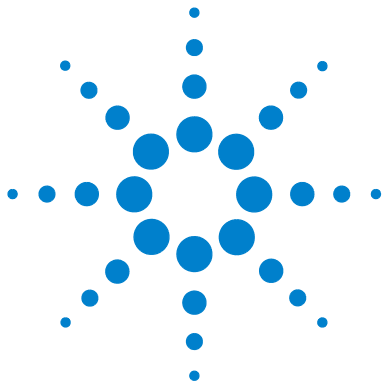

## 7 Tests and Calibration Functions

Pressure Test Description	96
Running the Pressure Test	98
Evaluating the Results	99
Pump Test	101
Running the Pump Test	102
Evaluating the Results	102
Binary Pump SL Solvent Calibration	103
Running the Solvent Compressibility Calibration	104

This chapter explains all test functions that are available for the Binary Pump SL.



## Pressure Test Description

### Description

The pressure test is a quick built-in test designed to demonstrate the leak tightness of the system. The test involves monitoring the flow profile while the pump delivers against a blank nut. The result is presented as the leak rate of the module and provides information about the leak tightness of the system between the outlet ball valves of the pump and the blank nut.

#### NOTE

The blank nut can be positioned anywhere between the purge valve of the pump and the detector inlet to pressure test the desired part of the system.

---

#### CAUTION

Blank not placed at the outlet of flow cell

The applied pressure may cause permanent leaks or bursting of the flow cell.

→ Never include the flow cell in the pressure test.

---

### Step 1

The test begins with the initialization of both pump heads. After initialization, the pump is starting the compression phase and the required flow rate is constantly monitored and adjusted. The pump continues to pump until a system pressure of around 600 bar is reached.

### Step 2

When the system pressure reaches 600 bar, the pump continues to pump at a flow rate that keeps the pressure constant. The flow that is needed to keep the pressure constant is directly translated into a leak rate.



### **Positioning the blank nut**

To test the complete system for pressure tightness, the blank nut should be positioned at the column compartment outlet (or the outlet of the last module in front of the detector).

If a specific component is suspected to cause the system leak, place the blank nut immediately in front of the suspected component, and run the pressure test again. If the test passes, the defective component is located behind the blank nut. Confirm the diagnosis by placing the blank nut immediately behind the suspected component. The diagnosis is confirmed if the test fails.

## Running the Pressure Test

Running the test from the Agilent LC Diagnostic Software

**When** The test should be used when problems with small leaks are suspected, or after maintenance of flow path components (e.g., pump seals, injection seal) to prove pressure tightness up to 600 bar

**Tools required**

- Wrench 1/4 - 5/16 inch, e.g. PN 8710-0510
- 1/16 inch blank nut, PN 01080-83202

**Preparations** Place two bottles of HPLC-grade water in channels A and B (A1 and B1 if the pump is equipped with a solvent selection valve)

### NOTE

Make absolutely sure that all parts of the flow path that are part of the test are very thoroughly flushed with water before starting to pressurize the system! Any trace of other solvents or the smallest air bubble inside the flow path definitely will cause the test to fail!

---

**1** Select the pressure test from the test selection menu.

**2** Start the test and follow the instructions.

### NOTE

Make sure to release the pressure by opening the purge valve when the test has finished completed. Otherwise the pump may generate an overpressure error.

---

## Evaluating the Results

The sum of all leaks between the pump and the blank nut will add up to the total leak rate. Note that small leaks may cause the test to fail, but solvent may not be seen leaking from a module.

### NOTE

Please notice the difference between an *error* in the test and a *failure* of the test! An *error* is caused by the abnormal termination during the operation of the test whereas a *failure* of a test indicates that the test results were not within the specified limits.

---

### If the pressure test fails:

- Ensure all fittings between the pump and the blank nut are tight. Repeat the pressure test.

### NOTE

Often it is only a damaged blank nut itself (poorly shaped from overtightening) that causes the test to fail. Before investigating on any other possible sources of failure make sure that the blank nut you are using is in good condition and properly tightened!

---

- If the test fails again, insert the blank nut at the outlet of the previous module in the stack (e.g. autosampler, port 6 of the injection valve), and repeat the pressure test. Exclude each module one by one to determine which module is leaking.
- If the pump is determined to be the source of the leak, run the pump test to identify the defective pump component.

### Potential Causes of Pressure Test Failure

After isolating and fixing the cause of the leak, repeat the pressure test to confirm the system is pressure tight.

**Table 10** Potential Cause (Pump)

Potential Cause (Pump)	Corrective Action
Purge valve open.	Close the purge valve.
Loose or leaky fitting.	Tighten the fitting or exchange the capillary.
Damaged pump seals or plungers.	Run the pump test to identify the defective component.
Loose purge valve.	Tighten the purge valve nut (14 mm wrench).

**Table 11** Potential Cause (Autosampler)

Potential Cause (Autosampler)	Corrective Action
Loose or leaky fitting.	Tighten or exchange the fitting or capillary.
Rotor seal (injection valve).	Exchange the rotor seal.
Damaged metering seal or plunger.	Exchange the metering seal. Check the plunger for scratches. Exchange the plunger if required.
Needle seat.	Exchange the needle seat.

**Table 12** Potential Cause (Column Compartment)

Potential Cause (Column Compartment)	Corrective Action
Loose or leaky fitting.	Tighten or exchange the fitting or capillary.
Rotor seal (column switching valve).	Exchange the rotor seal.

# Pump Test

## Description

The pump test provides a fast and accurate way to verify proper hydraulic operation of the Binary Pump SL. Problems related to defective valves, seals or pistons can be diagnosed and usually the defective part is identified.

## Step 1

The system is setup with water on both channels and a restriction capillary is attached to the outlet of the pump. Pump head A is delivering at 1 mL/min. The pressure signal is monitored and overlaid with the piston movement plot. The pressure pattern and the slope of the pressure signal are evaluated for the delivery strokes of both pistons.

## Step 2

The procedure from step 1 is repeated on pump head B.

## Step 3

The data from step 1 and 2 are evaluated. In case test failed, a conclusion about the defective part is made.

## Running the Pump Test

*Running the test from the Agilent LC Diagnostic Software*

**When** The test should be used to prove proper operation of the Binary Pump SL after repairs or when a the pressure test (see ["Pressure Test Description"](#) on page 96) determined a problem with the pump.

**Tools required**

- Wrench 1/4 - 5/16 inch, e.g. PN 8710-0510
- Restriction capillary, PN G1312-67500

**Preparations** Place two bottles of HPLC-grade water in channels A and B (A1 and B1 if the pump is equipped with a solvent selection valve)

### NOTE

Make absolutely sure that the pump is very thoroughly flushed with water before starting the test! Any trace of other solvents or the smallest air bubble inside the flow path definitely will cause the test to generate misleading results!

---

- 1 Select the pump test from the test selection menu.
- 2 Start the test and follow the instructions.

### NOTE

Make sure to release the pressure by opening the purge valve when the test has finished completed. Otherwise the pump may generate an overpressure error.

---

## Evaluating the Results

Refer to the help file of the Agilent LC Diagnostic Software for further details.

# Binary Pump SL Solvent Calibration

## Description

Each solvent or solvent mixture has unique compressibility at different pressures. In order to deliver accurate flow with minimal pressure- and composition ripple over the full operational pressure range, it is necessary that the Binary Pump SL compensates precisely for the compressibility of the solvents in use.

The Binary Pump SL comes with compressibility parameters for the most common HPLC solvents and solvent mixtures. If a solvent is not available in the list of pre-calibrated solvents, the solvent compressibility calibration allows the appropriate compressibility data to be generated.

## Technical background

The solvent compressibility calibration relies on an accurate elasticity calibration of the pump. With a proper elasticity calibration in place, the pump is switched into pressure control mode. A restriction capillary is connected to the purge valve outlet. By varying the flow rate, the pump maintains a certain pressure. The pump optimizes the compressibility value of the solvent until the lowest possible pump ripple is reached. The pump increases the flow rate and adjusts the pressure to the next calibration step where the pump ripple is minimized again. This process is repeated until solvent compressibility data for the whole operating pressure range of the pump are available.

The compressibility data set for this solvent is stored in an XML-file in C:\Documents and Settings\\Application Data\Agilent Technologies\Agilent Lab Advisor\2.02.0.0\data\. It can be shared with other G1312B pumps via the controlling data system.

## Running the Solvent Compressibility Calibration

*Running the Solvent Compressibility Calibration from the Agilent LC Diagnostic Software*

<b>When</b>	If a solvent is not available in the list of pre-calibrated solvents, the solvent compressibility calibration allows to generate appropriate compressibility data.
<b>Tools required</b>	<ul style="list-style-type: none"><li>• Wrench 1/4 - 5/16 inch, e.g. PN 8710-0510</li><li>• Restriction capillary, PN G1312-67500</li></ul>
<b>Preparations</b>	Place a bottles with solvent to be calibrated in channel A (resp. A1 if a solvent selection valve is installed).

### CAUTION

Avoid inaccurate pump elasticity calibration.

This would lead into invalid and not-portable solvent compressibility data.

→ Make sure to perform accurate pump elasticity calibration.

### NOTE

Make absolutely sure that the pump is very thoroughly flushed with the solvent to be calibrated before starting the procedure! Any trace of other solvents or the smallest air bubble inside the flow path definitely will cause the calibration to fail!

- 1 Select the solvent from the test selection menu.
- 2 Start the test and follow the instructions.

### NOTE

Make sure to release the pressure by opening the purge valve when the test has finished completed. Otherwise the pump may generate an overpressure error.



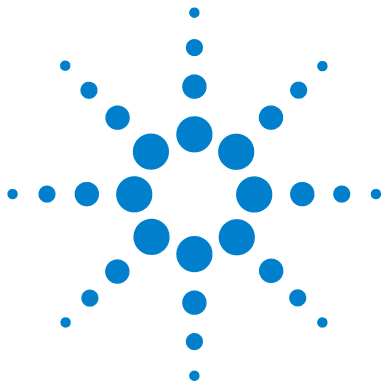

## 8 Diagnostic Signals

Analog Pressure Output	106
Description	106
Diagnostic Signals in the ChemStation Software	107
Directly Accessible Signals	107
Hidden Signals	107
Early Maintenance Feedback (EMF)	108
EMF Counters	109
Using the EMF Counters	109

This chapter explains all diagnostic signals and counter of the Binary Pump SL.



## Analog Pressure Output

### Description

A BNC connector at the rear of the Binary Pump SL provides the reading of the pressure sensor as analog value with a resolution of 1.33 mV/bar. The maximum reading of 660 bar equals 800 mV. The signal is available in real time and can be fed into an appropriate recording device (e.g. integrator or strip chart recorder) for troubleshooting purposes.

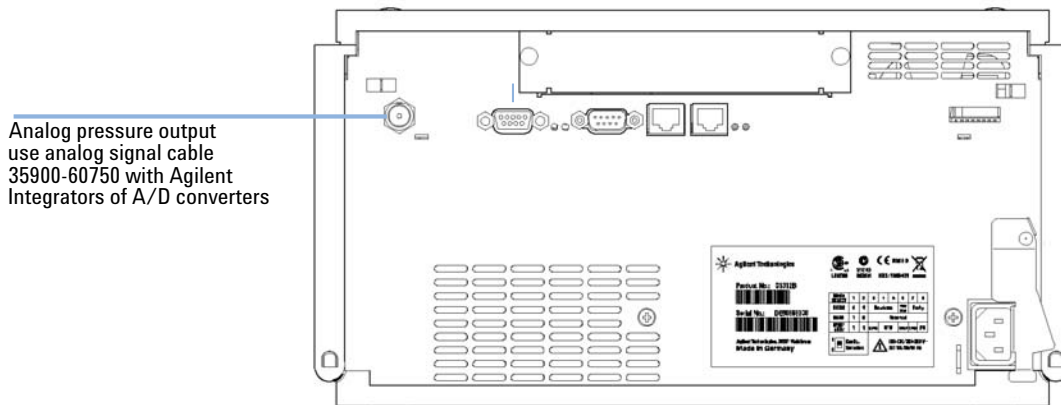

Figure 22 Location of Analog Output Connector

# Diagnostic Signals in the ChemStation Software

## Directly Accessible Signals

In ChemStation, the following instrument parameters are accessible during data acquisition and can be stored in the data file:

- actual pump pressure
- solvent composition (gradient)

## Hidden Signals

### Piston Movement

When overlaid with the pump pressure signal, this function allows to diagnose valve problems. However, it is recommended to use the pump test (see “[Pump Test](#)” on page 101) instead as it is optimized for use with the Binary Pump SL.

The piston movement signal needs to be turned on by typing the following command into the ChemStation command line:

```
lpmpdiagmode 1
```

ChemStation resets this function upon bootup. It is necessary to turn it back on every time ChemStation is restarted. If needed, the function can be manually disabled by typing the command below into the ChemStation command line.

```
lpmpdiagmode 0
```

## Early Maintenance Feedback (EMF)

Components in the flow path are subject to mechanical wear or stress and require regular maintenance. Ideally, the frequency at which components are exchanged should be based on the intensity of usage of the instrument and the analytical conditions, and not on a predefined time interval. The early maintenance feedback (EMF) feature monitors the usage of specific components in the instrument, and provides feedback when the user-settable limits are exceeded. The visual feedback in the user interface indicates when maintenance procedures should be scheduled.

## EMF Counters

The Binary Pump SL provides a series of EMF counters for the left and right pump heads. Each counter increments with pump use and can be assigned a maximum limit which provides visual feedback in the user interface when the limit is exceeded. Each counter can be reset to zero after maintenance has been done. The Binary Pump SL provides the following EMF counters:

- liquimeter pump A,
- seal wear pump A,
- liquimeter pump B, and
- seal wear pump B.

### Liquimeters

The liquimeters display the total volume of solvent pumped by the left and right pump heads since the last reset of the counters. Both liquimeters can be assigned an EMF (maximum) limit. When the limit is exceeded, the EMF flag in the user interface is displayed.

### Seal Wear Counters

The seal wear counters display a value derived from pressure and pumped volume (both contribute to seal wear). The values increment with pump usage until the counters are reset after seal maintenance. Both seal wear counters can be assigned an EMF (maximum) limit. When the limit is exceeded, the EMF flag in the user interface is displayed.

## Using the EMF Counters

The use of the EMF counter is described in “[Early Maintenance Feedback \(EMF\)](#)” on page 70

## **8 Diagnostic Signals**

### Early Maintenance Feedback (EMF)

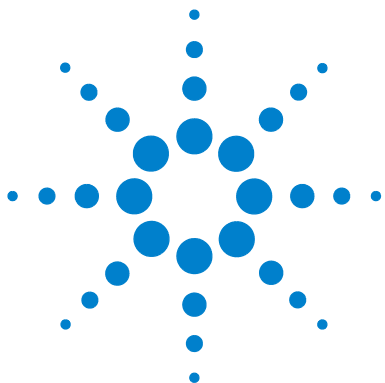

## 9 Maintenance

Introduction to Maintenance and Repair	112
Simple Repairs - Maintenance	112
Exchanging Internal Parts - Repair	112
Warnings and Cautions	113
Cleaning the module	114
Using the ESD Strap	115
Overview of Maintenance and Simple Repairs	116
Maintenance Procedures	117
Exchanging the Purge Valve Frit or the Purge Valve	118
Removing the Pump Head Assembly	121
Disassembling the pump head	123
Exchanging the Pump Seals	124
Seal Wear-in Procedure	126
Exchanging the Plungers	127
Exchanging the Wash Seals	128
Reinstalling the Pump Head Assembly	130
Simple Repair Procedures	132
Exchanging the Active Inlet Valve Cartridge	133
Exchanging the Active Inlet Valve Body	135
Exchanging the Outlet Ball Valve	138
Exchanging the Solvent Selection Valve	141
Exchanging the Optional Interface Board	143
Replacing the Pump's Firmware	144

This chapter describes all maintenance and simple repair procedures that can be performed without removing the pump from the system stack.



## Introduction to Maintenance and Repair

### Simple Repairs - Maintenance

The pump is designed for easy repair. The most frequent repairs such as piston seal replacement and purge valve frit exchange can be done from the front side without removing the pump from the system stack. These repairs are described in “[Overview of Maintenance and Simple Repairs](#)” on page 116 (part of the *User Manual* and *Service Manual*).

### Exchanging Internal Parts - Repair

Some repairs require the exchange of defective internal parts. Exchange of these parts involves removing the pump from the stack, removing the covers, and disassembling the module. The security lever at the power input socket prevents that the detector cover is taken off when line power is still connected. These repairs are described in the Binary Pump SL Service Manual.



## Warnings and Cautions

### WARNING

**Module is partially energized when switched off, as long as the power cord is plugged in.**

**Repair work at the module can lead to personal injuries, e.g. shock hazard, when the cover is opened and the module is connected to power.**

- Make sure that it is always possible to access the power plug.
  - Remove the power cable from the instrument before opening the cover.
  - Do not connect the power cable to the Instrument while the covers are removed.
- 

### WARNING

**When opening capillary or tube fittings solvents may leak out.**

**The handling of toxic and hazardous solvents and reagents can hold health risks.**

- Please observe appropriate safety procedures (for example, goggles, safety gloves and protective clothing) as described in the material handling and safety data sheet supplied by the solvent vendor, especially when toxic or hazardous solvents are used.
- 

### WARNING

**Sharp metal edges**

**Sharp-edged parts of the equipment may cause injuries.**

- To prevent personal injury, be careful when getting in contact with sharp metal areas.
-

## Cleaning the module

The module case should be kept clean. Cleaning should be done with a soft cloth slightly dampened with water or a solution of water and mild detergent. Do not use an excessively damp cloth as liquid may drip into the module.

### WARNING

**Liquid dripping into the electronic compartment of your module.**

**Liquid in the module electronics can cause shock hazard and damage the module.**

- Do not use an excessively damp cloth during cleaning.
  - Drain all solvent lines before opening any fittings.
-

## Using the ESD Strap

Electronic boards are sensitive to electrostatic discharge (ESD). In order to prevent damage, always use an ESD strap when handling electronic boards and components.

- 1 Unwrap the first two folds of the band and wrap the exposed adhesive side firmly around your wrist.
- 2 Unroll the rest of the band and peel the liner from the copper foil at the opposite end.
- 3 Attach the copper foil to a convenient and exposed electrical ground.

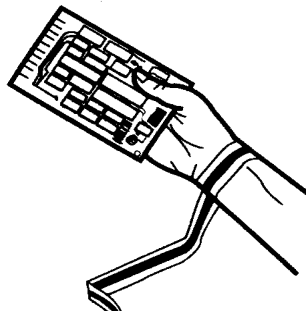

**Figure 23** Using the ESD Strap

## Overview of Maintenance and Simple Repairs

Figure 24 on page 116 shows the main user accessible assemblies of the Binary Pump SL. The pump heads and its parts do require normal maintenance (for example, seal exchange) and can be accessed from the front (simple repairs). Replacement of valve cartridges or filters don't require to remove the pump from the system stack.

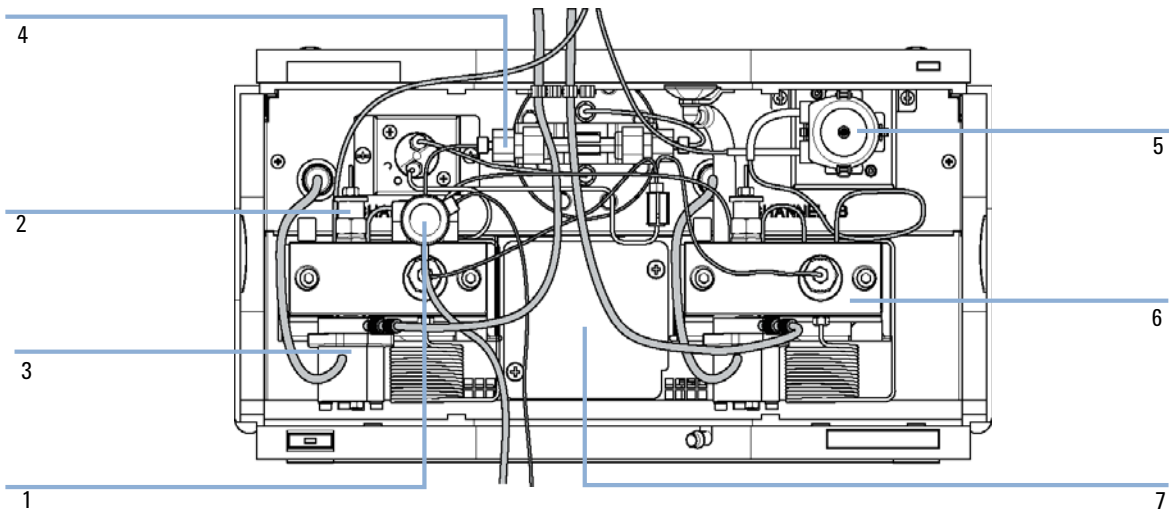

**Figure 24** Overview of Maintenance and Simple Repair Procedures

1	Purge valve “Exchanging the Purge Valve Frit or the Purge Valve” on page 118
2	Outlet ball valve “Exchanging the Outlet Ball Valve” on page 138
3	Active inlet valve “Exchanging the Active Inlet Valve Body” on page 135
4	Delay volume reduction
5	Seal wash option
6	Pump head “Removing the Pump Head Assembly” on page 121
7	Solvent selection valve “Exchanging the Solvent Selection Valve” on page 141

## Maintenance Procedures

The procedures described in this section can be done with the Binary Pump SL in place in the system stack.

**Table 13** Maintenance Procedures

Procedure	Typical Frequency	Notes
<a href="#">“Exchanging the Purge Valve Frit or the Purge Valve”</a> on page 118	Yearly, or if the frit shows indication of contamination or blockage	A pressure drop of > 10 bar across the frit (5 mL/min H <sub>2</sub> O with purge valve open) indicates blockage
<a href="#">“Removing the Pump Head Assembly”</a> on page 121	During yearly maintenance	Necessary to get access to pump seals and plungers.
<a href="#">“Disassembling the pump head”</a> on page 123	During yearly maintenance	Necessary to get access to pump seals and plungers.
<a href="#">“Exchanging the Pump Seals”</a> on page 124	Yearly, or if pump performance indicates seal wear	Leaks at lower pump head side, unstable retention times, pressure ripple unstable — run pump test for verification
<a href="#">“Exchanging the Plungers”</a> on page 127	If scratched or if dents are visible	Seal life time shorter than normally expected — check plungers while changing the seals
<a href="#">“Exchanging the Wash Seals”</a> on page 128	Yearly	Only necessary when Seal Wash Option is installed. Leaks at lower pump head side, loss of wash solvent

## Exchanging the Purge Valve Frit or the Purge Valve

**When** Frit - when plunger seals are exchanged or when contaminated or blocked (pressure drop of > 10 bar across the frit at a flow rate of 5 mL/min of H<sub>2</sub>O with purge valve opened)  
Purge valve - if purge valve cannot be closed leak tight

**Tools required** Wrench 1/4 inch  
Wrench 14 mm  
Pair of tweezers or toothpick

**Parts required**

#	Part number	Description
1	01018-22707	PTFE Frit (pack of 5)
1	G1312-60023	Purge valve

- 1 Using a 1/4 inch wrench disconnect the pump outlet capillary at the purge valve.
- 2 Disconnect the waste tube. Beware of leaking solvents due to hydrostatic pressure.
- 3 Using the 14 mm wrench, unscrew the purge valve and remove it from the purge valve holder.
- 4 Remove the plastic cap with the gold seal from the purge valve.

- 5 Use a pair of tweezers or a toothpick to remove the frit.

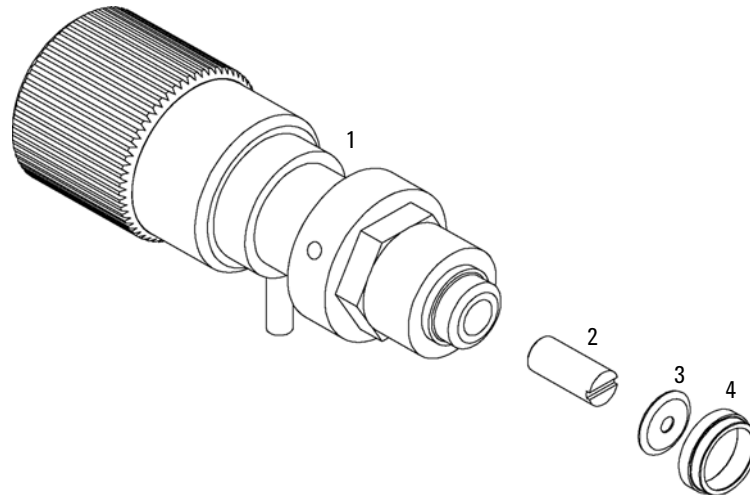

**Figure 25** Purge Valve Parts

1	Valve body
2	PTFE frit
3	Gold seal
4	Plastic cap

- 6 Place a new frit into the purge valve with the slit facing the gold seal (see [Figure 25](#) on page 119).
- 7 Replace the cap with the gold seal.

**NOTE**

Before reinstallation always check the gold seal. A deformed seal or a cracked cap should be replaced.

- 8 Insert the purge valve into the purge valve holder and orient the waste outlet nozzle downward as shown below.

## 9 Maintenance

### Maintenance Procedures

- 9 Tighten the purge valve and reconnect outlet capillary and waste tubing.

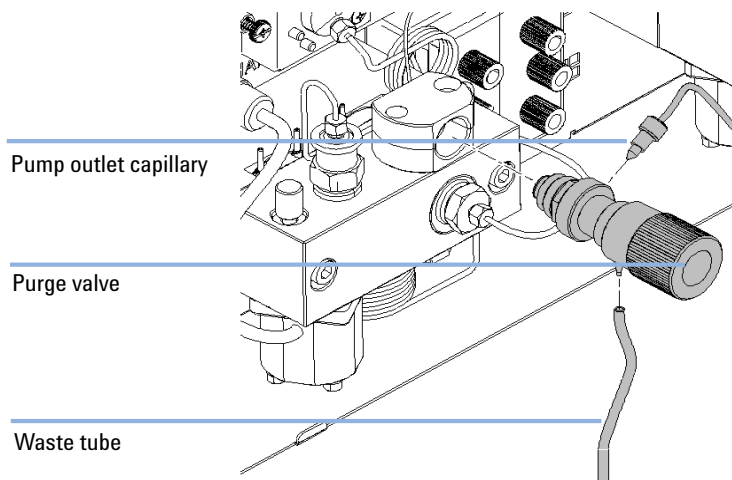

**Figure 26** Exchanging the Purge Valve



## Removing the Pump Head Assembly

**When** Exchanging pump seals  
Exchanging plungers  
Exchanging seals of the seal wash option

**Tools required** Wrench 1/4 inch  
3-mm hexagonal key  
4-mm hexagonal key  
1/4 inch slitted socket wrench

**Preparations** Switch off the Binary Pump SL at power switch

### CAUTION

Make sure that the pump head is not removed.

This may damage the pump drive.

→ Never start the pump when the pump head is removed.

### NOTE

Both pump head assemblies use the same internal components. In addition, pump head A is fitted with the purge valve. The following procedure describes the removal and disassembly of pump head A (left). For pump head B (right) proceed in the same way and skip steps that deal with the purge valve.

- 1 Remove the front cover.
- 2 Disconnect the capillary at the pump head adapter and the tube at the active inlet valve. Beware of leaking solvents.
- 3 Using a 3-mm hexagonal key loosen the purge valve holder and lift it up.
- 4 Disconnect the Active Inlet Valve cable.

**9 Maintenance**  
Maintenance Procedures

- 5 Using a 4-mm hexagonal key stepwise loosen and remove the two pump head screws

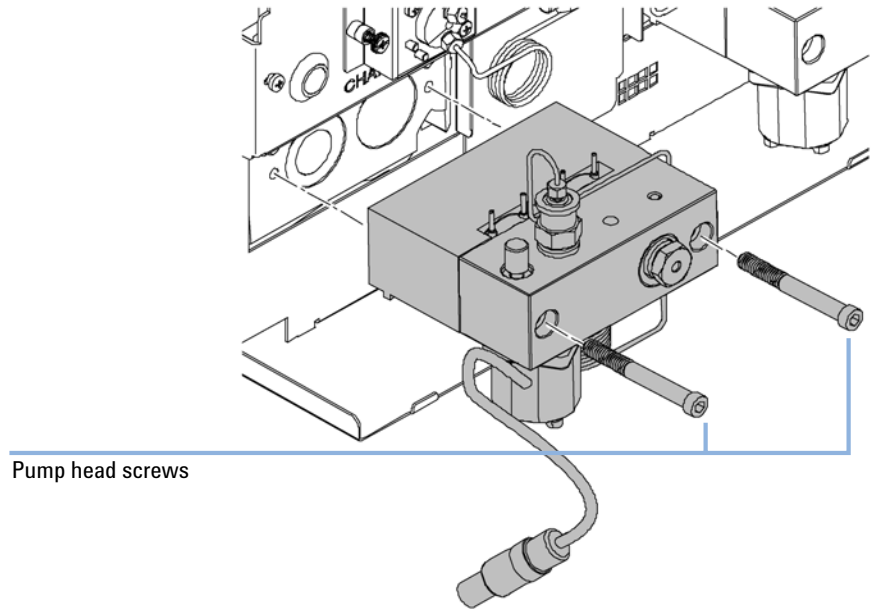

**Figure 27** Removing the Pump Head

## Disassembling the pump head

- 1 Place the pump head with the front face onto a bench.
- 2 Open the two hex screws on the rear side with a 3 mm hex driver.
- 3 Open the PEEK lock screw two to three turns.
- 4 Pull the spring housing up and remove it from the pump head.

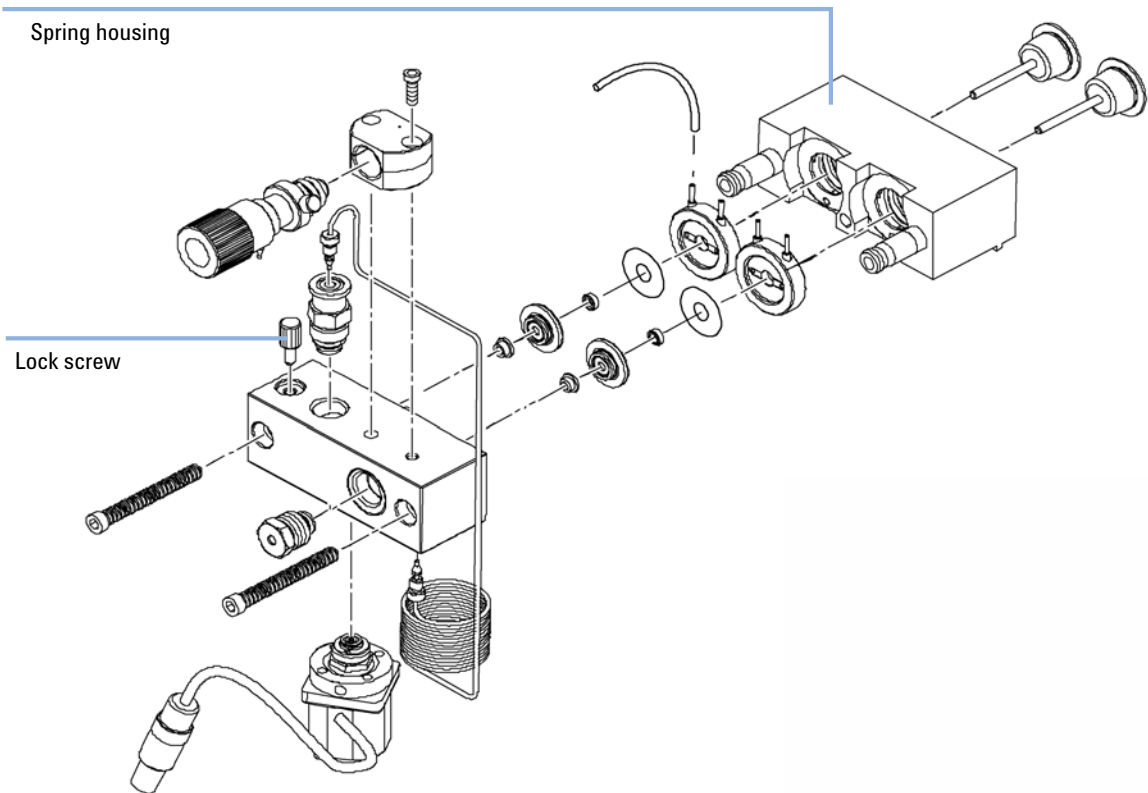

## Exchanging the Pump Seals

**When** Seals leaking, if indicated by the results of the pump test (check both pump heads individually!)

**Tools required** 3-mm hexagonal key  
4-mm hexagonal key  
1/4 inch wrench

<b>Parts required</b>	<b>#</b>	<b>Part number</b>	<b>Description</b>
	1	5065-6589	Seals (pack of 2) (standard) or <a href="#">Table 18</a> on page 152 (for normal phase application)
	1	5022-2159	Restriction capillary (for the seal wear-in procedure)

**Preparations** Switch off Binary Pump SL at power switch  
Remove the front cover to have access to the pump mechanics

- 1 Disassemble the pump head assembly, see “[Disassembling the pump head](#)” on page 123.
- 2 Use one of the plungers to carefully remove the seal from the pump head (be careful not to break the plunger).

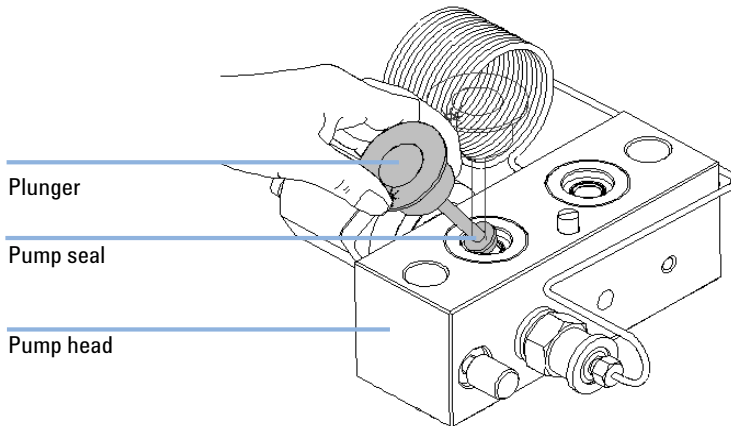

**Figure 28** Removing the Pump Seals from the Pump Head

- 3 Insert seals into the pump head and press firmly in position.

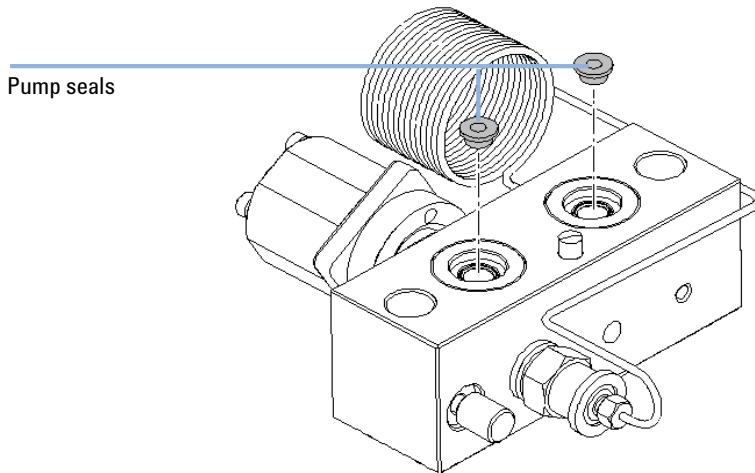

**Figure 29** Inserting of new Pump Seals

- 4 Reassemble the pump head assembly (see [“Reinstalling the Pump Head Assembly”](#) on page 130).

**NOTE**

Reset the seal wear counter and liquimeter with the in the Agilent LC Diagnostic software.

## Seal Wear-in Procedure

**NOTE**

This procedure is required for standard seals only (part no. 5063-6589), but it will definitely damage the normal phase application seals (part no. 0905-1420).

---

- 1** Put a bottle with 100 ml of isopropanol in the solvent cabinet and place the solvent intake filter of the pump head you want to wear in into this bottle.
- 2** Screw the PEEK adapter (part no. 0100-1847) onto the Active Inlet Valve and connect the inlet tube directly to it.
- 3** Connect the restriction capillary (part no. 5022-2159) to the purge valve. Put its other end into a waste container.
- 4** Open the purge valve and purge the system for 5 minutes with isopropanol at a flow rate of 2 mL/min.
- 5** Close the purge valve, set the flow to a value that gives a pressure of 350 bar. Pump 15 minutes at this pressure to wear the seals in. The pressure can be monitored on the analog output connector of the pump, with the Instant Pilot, Chemstation or any other controlling device connected to your pump.
- 6** Turn the pump *Off*, slowly open the purge valve to release the pressure from the system, disconnect the restriction capillary and reconnect the outlet capillary to the purge valve. Reconnect the intake tubing to the solvent selection valve and the connecting tube from solvent selection valve (if installed) to the AIV.
- 7** Purge your system with the solvent used for your next application.

## Exchanging the Plungers

**When** When scratched

**Tools required** 3-mm hexagonal key  
4-mm hexagonal key

Parts required	#	Part number	Description
	1	5063-6586	Plunger

**Preparations**

- Switch off Binary Pump SL at power switch
- Remove the front cover to have access to the pump mechanics
- [“Removing the Pump Head Assembly”](#) on page 121
- [“Disassembling the pump head”](#) on page 123

- 1 Check the plunger surface and remove any deposits or layers. Most suitable is polishing of the plunger rod with toothpaste. Replace the plunger if scratched or if dents are visible.

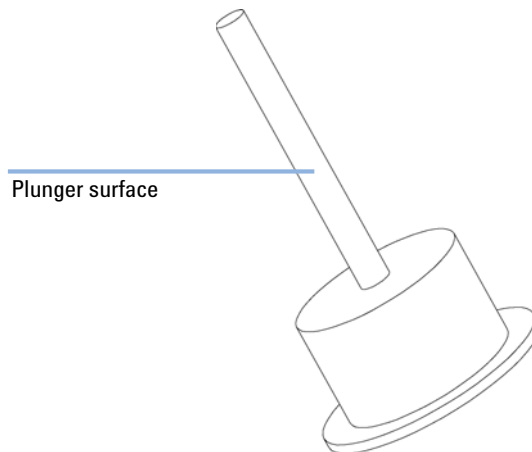

**Figure 30** Plunger

### NOTE

The best way to inspect a piston is to hold it up and watch e.g. a light bulb through the piston rod. The transparent sapphire acts as a very strong magnifier and even smallest surface abnormalities become visible.

## Exchanging the Wash Seals

**Tools required**

- 3-mm hexagonal key
- 4-mm hexagonal key
- Insert tool
- Small flat-head screwdriver

**Parts required**

#	Part number	Description
1	0905-1175	Wash seal
1	5062-2484	Gasket, seal wash (pack of 6)

**Preparations**

- Switch off Binary Pump SL at power switch
- Remove the front cover to have access to the pump mechanics
- ["Removing the Pump Head Assembly"](#) on page 121
- ["Disassembling the pump head"](#) on page 123

**1** Remove the seal keeper and the seal wash support rings from the plunger housing. Remove the seal keeper from the support ring assembly.

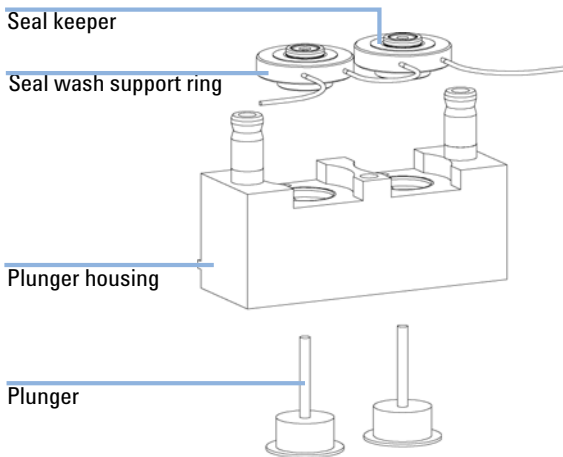

**2** Using the blade of a flat head screwdriver remove seal wash gasket and the secondary seal from the support ring.

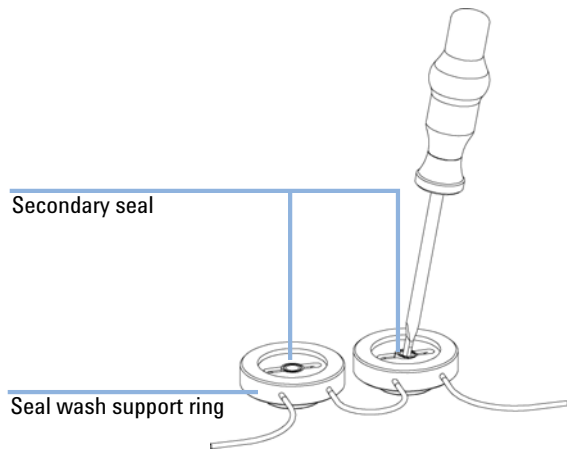



- 3** Using the insert tool press the seal (spring pointing upwards) into the recess of the support ring. Place a seal wash gasket in the recess of the support ring and replace the seal keeper.

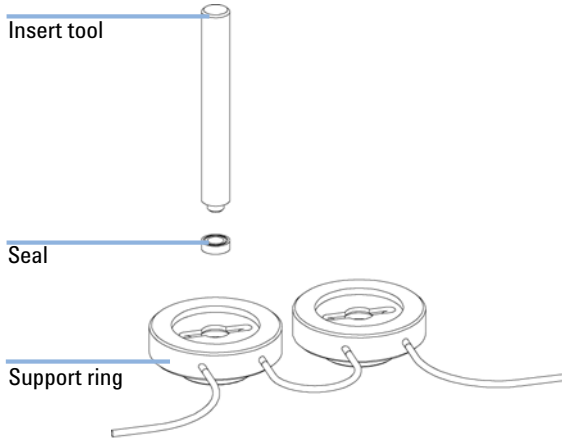

- 4** Reassemble the pump head assembly (see "Reinstalling the Pump Head Assembly" on page 130).

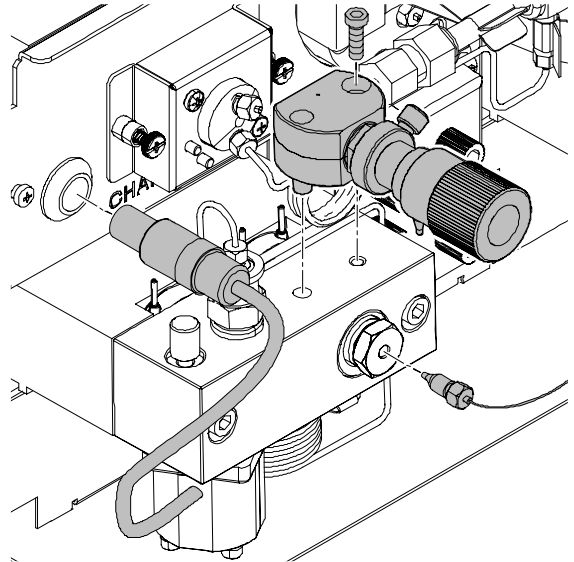

## Reinstalling the Pump Head Assembly

**When** When reassembling the pump

**Tools required** 3-mm hexagonal key  
4-mm hexagonal key

**Parts required**

#	Part number	Description
1	79841-65501	lubricant

- 1 Slide the pump head assembly onto the pump drive.

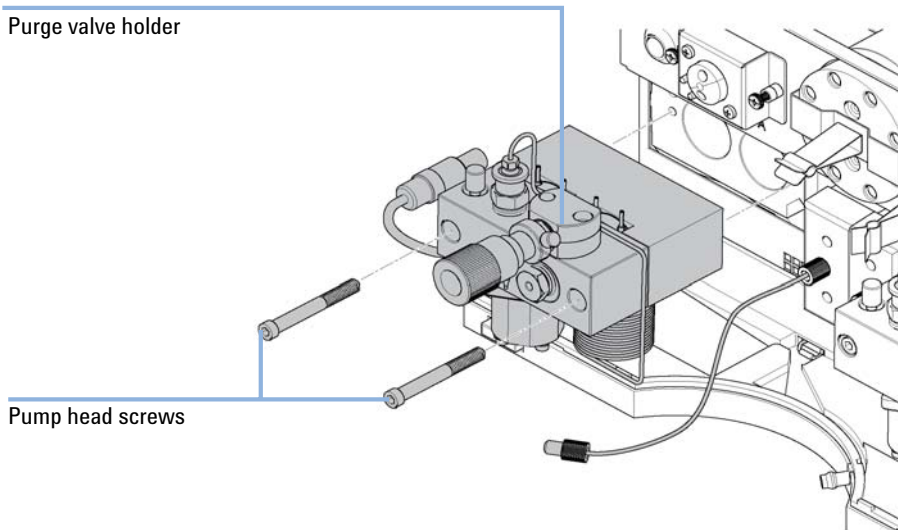

- 2 Using a 4 mm hexagonal key tighten the pump head screws stepwise with increasing torque.
- 3 Using a 3 mm hexagonal key fix the purge valve holder to the pump head.

- 4 Reconnect the capillaries, tubing and the active inlet valve cable to the connector.

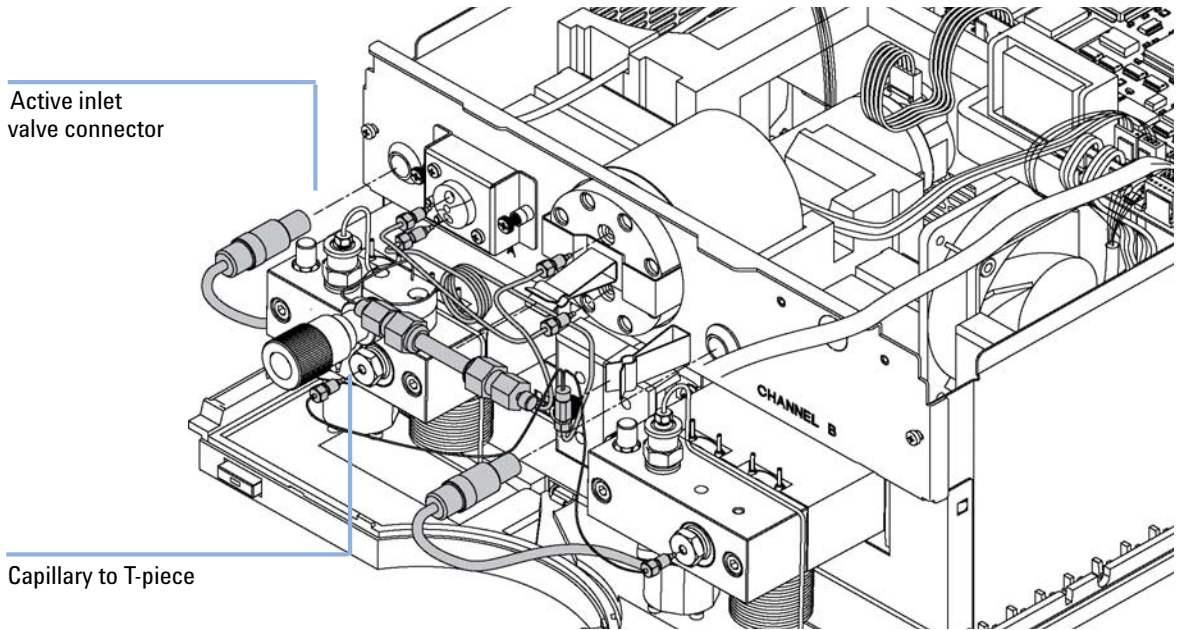

**Figure 31** Reinstallation of Pump head Capillaries and AIV Connector

## Simple Repair Procedures

The procedures described in this section can be done with the Binary Pump SL in place in the system stack.

**Table 14** Simple Repair Procedures

Procedure	Typical Frequency	Notes
"Exchanging the Purge Valve Frit or the Purge Valve" on page 118	If internally leaking	Solvent dripping out of waste outlet when valve is closed
"Exchanging the Active Inlet Valve Cartridge" on page 133	If internally leaking	Pressure ripple unstable, run leak test for verification
"Exchanging the Active Inlet Valve Body" on page 135	If leaking externally If solenoid is defective	Error messages "Inlet Valve Fuse" or "Inlet Valve Missing"
"Exchanging the Outlet Ball Valve" on page 138	If internally leaking	Pressure ripple unstable, run leak test for verification
"Exchanging the Solvent Selection Valve" on page 141	If internally leaking If solenoid is defective	Cross port flow Error message "Valve Failed"
Installing the Active Seal Wash Option (see Service Manual).	When upgrading to Active Seal Wash	Recommended if buffers of > 0.1M are used regularly.

## Exchanging the Active Inlet Valve Cartridge

**When** If internally leaking (backflow)

**Tools required** Wrench 14 mm

<b>Parts required</b>	<b>#</b>	<b>Part number</b>	<b>Description</b>
	1	G1312-60020	Cartridge for active inlet valve 600bar

**Preparations** Switch off Binary Pump SL at power switch

- 1 Remove the front cover.
- 2 Unplug the active inlet valve cable from the connector.
- 3 Disconnect the solvent inlet tube at the inlet valve (beware of leaking solvents).

### NOTE

Binary Pump SLs without the solvent selection valve (SSV) have an adapter installed between the solvent line and the active inlet valve (AIV). Disconnect the solvent tubes at the adapter and remove the adapter from the AIV.

- 4 Using a 14-mm wrench loosen the active inlet valve and remove the valve from the pump head.
- 5 With a pair of tweezers, remove the valve cartridge from the active inlet valve.
- 6 Clean the inside of the active inlet valve body. Flush the cartridge area thoroughly.
- 7 Push a new valve cartridge into the valve body. Make sure the valve cartridge is fully inserted.
- 8 Screw the valve into the pump head. Using the 14 mm wrench turn the nut until it is hand tight.
- 9 Position the valve so that the solvent inlet tube connection points towards the front.

### CAUTION

Ensure correct fit of the active inlet valve  
Overtightening will destroy the active inlet valve cartridge.

→ Tighten the active inlet valve properly.

## 9 Maintenance

### Simple Repair Procedures

- 10 Using the 14 mm wrench tighten the nut by turning the valve in its final position (do not overtighten the valve).
- 11 Reconnect the Active Inlet Valve cable to the connector in the Z-panel and the inlet tube to the valve.
- 12 Reinstall the front cover.

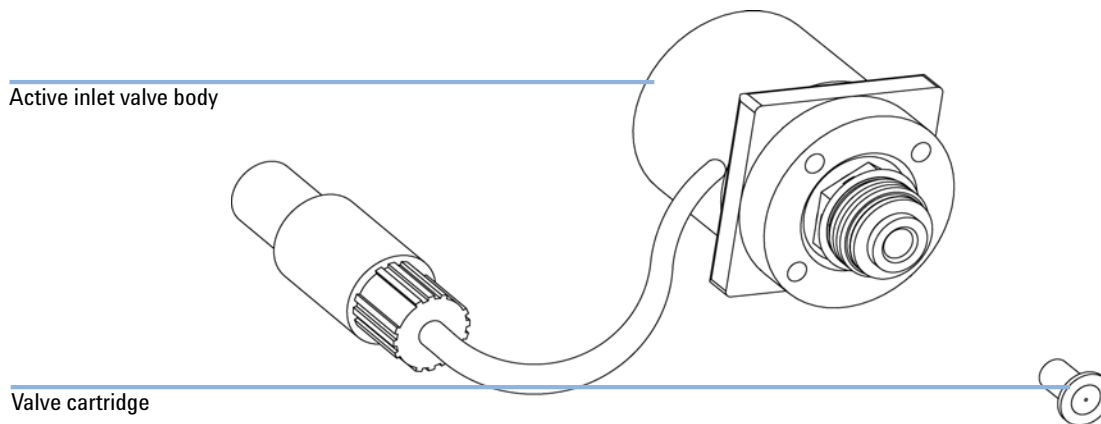

**Figure 32** Replacement of the Active Inlet Valve Cartridge

#### NOTE

After an exchange of the valve it may be required to pump several mL of solvent before the flow stabilizes at a pressure ripple as low as it used to be when the system was still working properly.

## Exchanging the Active Inlet Valve Body

- When**
- External leak (leak sensor is activated, or
  - Error message "Inlet Valve Fuse"
  - Error message "Inlet Valve Missing"

**Tools required** Wrench 14 mm

**Parts required**

#	Part number	Description
1	G1312-60025	Active inlet valve without cartridge

**Preparations** Switch off Binary Pump SL at power switch

- 1 Remove the front cover.
- 2 Unplug the active inlet valve cable from the connector.
- 3 Disconnect the solvent inlet tube at the inlet valve (beware of leaking solvents).

### NOTE

Binary Pump SLs without the solvent selection valve (SSV) have an adapter installed between the solvent line and the active inlet valve (AIV). Disconnect the solvent tubes at the adapter and remove the adapter from the AIV.

## 9 Maintenance

### Simple Repair Procedures

- Using a 14-mm wrench, loosen the active inlet valve and remove the valve from pump head.

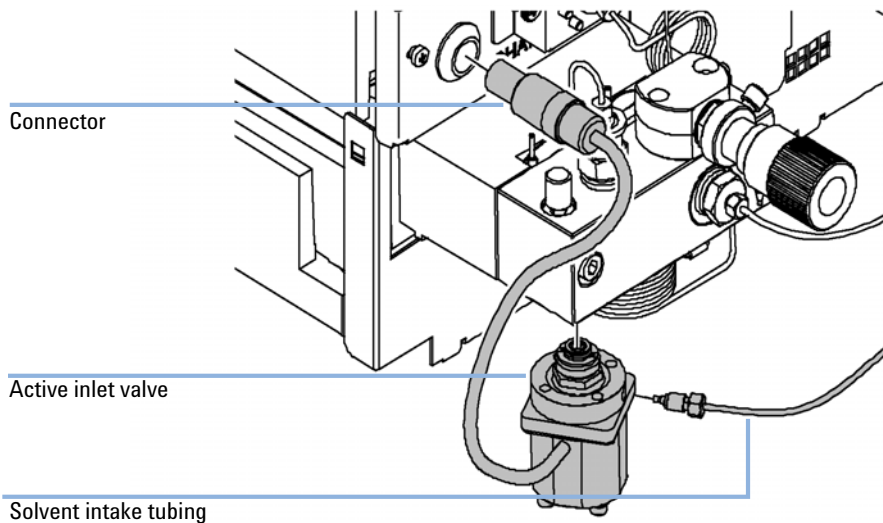

**Figure 33** Removal of Active Inlet Valve

- Using a pair of tweezers, remove the valve cartridge from the defective active inlet valve.
- Push the cartridge into the new active inlet valve.

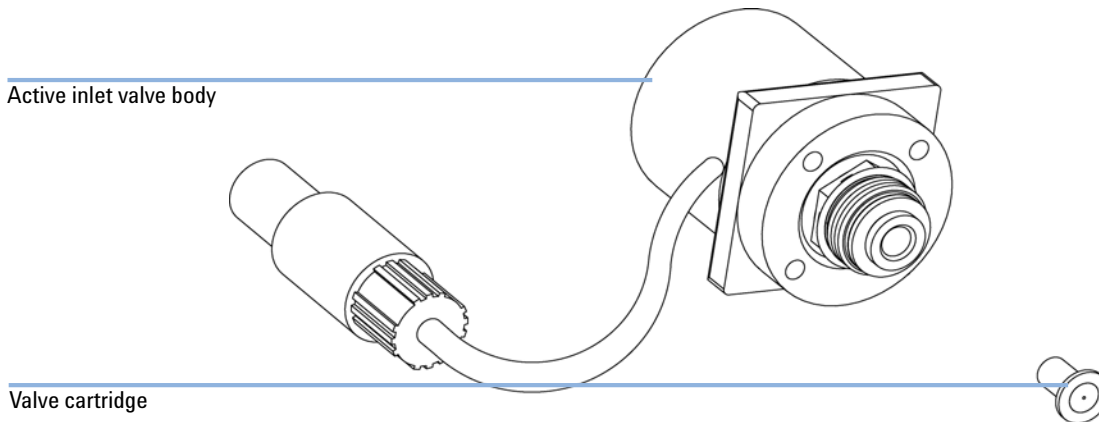

**Figure 34** Replacement of the Active Inlet Valve Cartridge



- 7 Insert the new valve into the pump head. With the 14 mm wrench turn the nut until it is hand tight.
- 8 Position the valve so that the solvent inlet tube connection points towards the front.

**CAUTION**

Ensure correct fit of the active inlet valve

Overtightening will destroy the active inlet valve cartridge.

→ Tighten the active inlet valve properly.

---

- 9 Using the 14 mm wrench tighten the nut by turning the valve in its final position (not more than a quarter turn). Do not overtighten the valve.
- 10 Reconnect the Active Inlet Valve cable to the connector in the Z-panel and the inlet tube to the valve.
- 11 Reinstall the front cover.

**NOTE**

After an exchange of the valve it may be required to pump several mL of the solvent used in the current application before the flow stabilizes at a pressure ripple as low as it used to be when the system was still working properly.

---

## Exchanging the Outlet Ball Valve

<b>When</b>	if leaking internally						
<b>Tools required</b>	tools:wrench 1/4 - 5/16 inchWrench 1/4 inch Wrench 14 mm						
<b>Parts required</b>	<table><thead><tr><th>#</th><th>Part number</th><th>Description</th></tr></thead><tbody><tr><td>1</td><td>G1312-60022</td><td>Outlet ball valve</td></tr></tbody></table>	#	Part number	Description	1	G1312-60022	Outlet ball valve
#	Part number	Description					
1	G1312-60022	Outlet ball valve					
<b>Preparations</b>	Switch off Binary Pump SL						

### NOTE

Before exchanging the outlet ball valve you can try to clean it in an ultrasonic bath. Remove the gold seal and put the plastic cap back on to protect the sealing surface from scratches. Place the valve in upright position (sitting on the plastic cap) in a small beaker with premixed water/isopropanol (50/50). Sonicate for 5 to 10 minutes. Replace the gold seal.

- 1 Using a 1/4 inch wrench disconnect the valve capillary from the outlet ball valve.
- 2 Unscrew the valve with the 14 mm wrench and remove it from the pump body.

- 3 In case you are only sonicating the valve, check the plastic cap and the gold seal for damage.

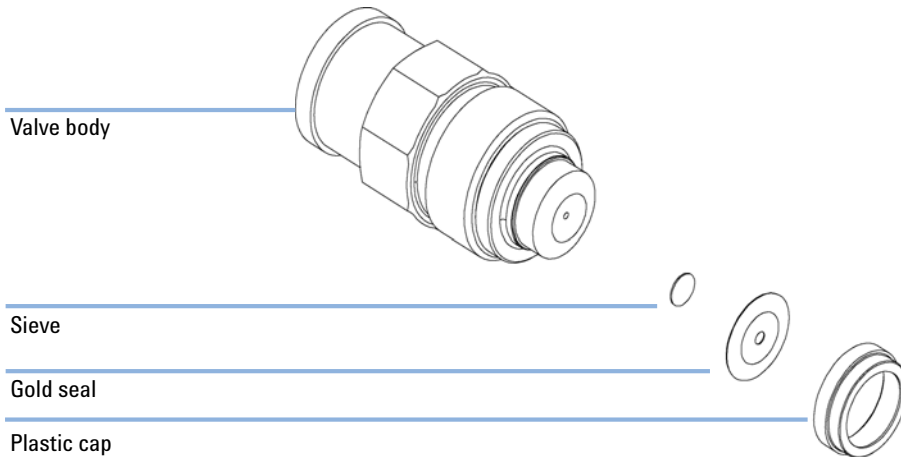

**Figure 35** Outlet Ball Valve

**NOTE**

Check the gold seal. It should be exchanged when heavily deformed. Inspect the cap and replace it with a new one if cracks are visible.

- 4 Reinstall the outlet ball valve and tighten it.

**9 Maintenance**  
Simple Repair Procedures

**5** Reconnect the valve capillary.

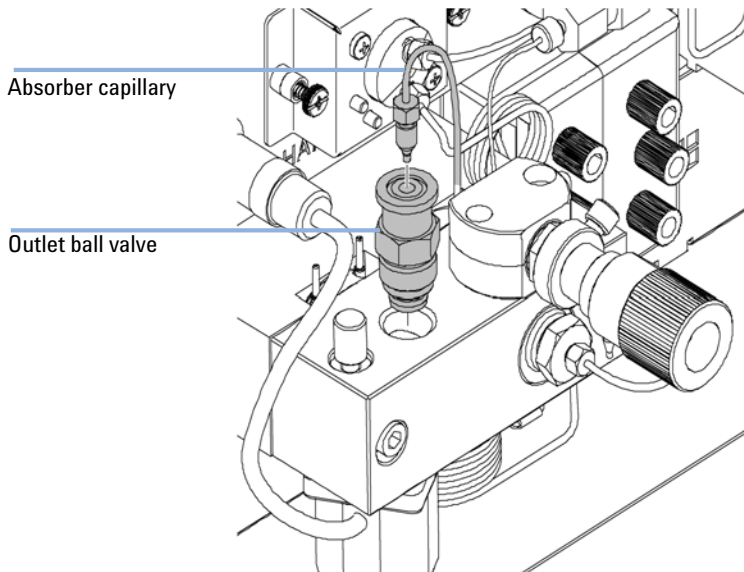

**Figure 36** Outlet Ball Valve Replacement

## Exchanging the Solvent Selection Valve

**When** If leaking internally ( crossflow between the ports), or if one of the channels is blocked

**Tools required** Screwdriver Pozidriv #1

**Parts required**

#	Part number	Description
1	G1312-60000	Solvent selection valve (PN gives half of a complete solvent selection block)

- 1** Lift solvent bottle A1 out of the solvent cabinet and place it on the table. Disconnect the solvent tube from channel A1 (upper left) of the solvent selection valve and empty the tube into the bottle. Place the bottle back into the solvent cabinet.
- 2** Repeat step 1) for the remaining solvent channels.
- 3** Disconnect the active inlet valve connection tubes from the solvent selection valve.
- 4** Using a Pozidrive screwdriver #1 loosen the holding screws of the valves.
- 5** Pull the valve module out.
- 6** Hold the two plastic bodies of the valves and pull the two solvent selection valves apart.
- 7** Exchange the defective solvent selection valve. Join the new valve (new half) and the properly working old one.
- 8** Push the valve module into the cutout of the pump body until the electrical connectors are properly seated and fix the assembly with the two holding screws.

## 9 Maintenance

### Simple Repair Procedures

9 Reinstall solvent tubes and the active inlet valve connection tubes.

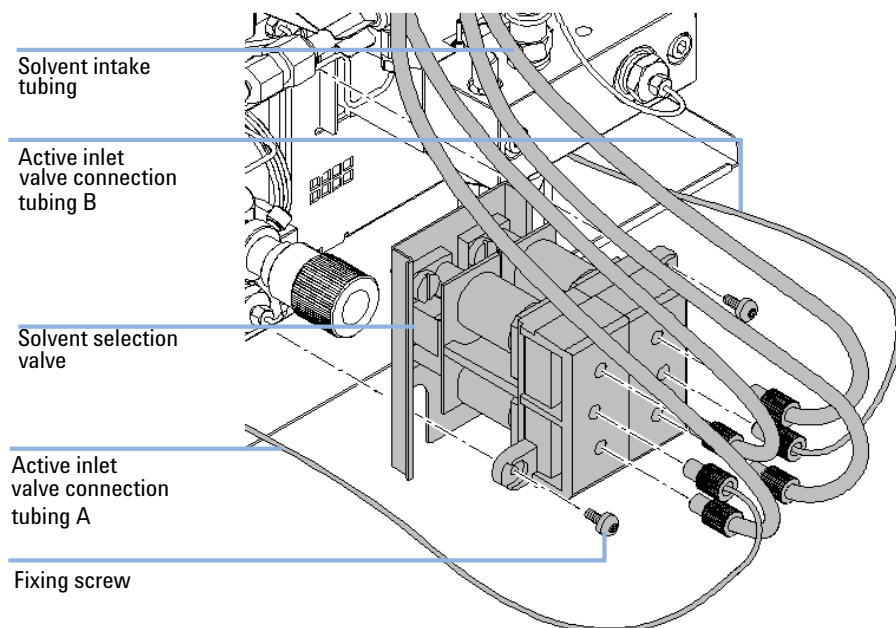

**Figure 37** Solvent Selection Valve Replacement

## Exchanging the Optional Interface Board

**When** Board defective

**Parts required**

#	Description
1	BCD (Interface) board, see service manual

### CAUTION

Electronic boards and components are sensitive to electrostatic discharge (ESD). ESD can damage electronic boards and components.

→ In order to prevent damage always use an ESD protection when handling electronic boards and components.

- 1 Switch OFF the module at the main power switch. Unplug the module from main power.
- 2 Disconnect cables from the interface board connectors.
- 3 Loosen the screws. Slide out the interface board from the module.
- 4 Install the new interface board. Secure screws.
- 5 Reconnect the cables to the board connector

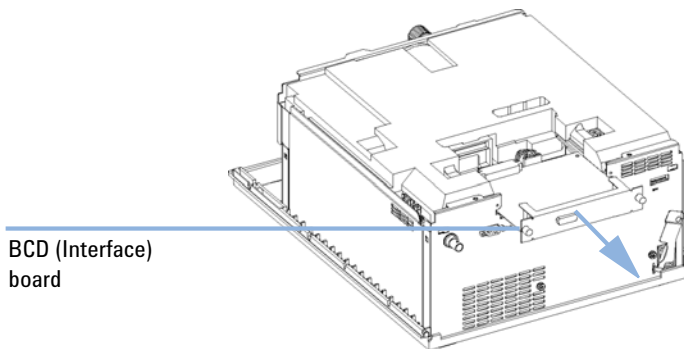

**Figure 38** Exchanging the Interface Board

## Replacing the Pump's Firmware

The installation of *older* firmware might be necessary:

- to keep all systems on the same (validated) revision, or
- if third part control software requires a special version.

To upgrade/downgrade the pumps's firmware the following steps have to be performed:

<b>When</b>	If a new version resolves problems of the currently installed version or if the firmware version of a new CSM board is different from the previous one.
<b>Tools required</b>	LAN/RS-232 Firmware Update Tool, or Instant Pilot G4208A
<b>Parts required</b>	<b>Description</b> Firmware, tools and documentation from Agilent web site
<b>Preparations</b>	Read update documentation provided with the Firmware Update Tool.  <ol style="list-style-type: none"><li>1 Download the module's firmware, the LAN/RS-232 FW Update Tool version 2.1 or above and the documentation from the Agilent web site:<ul style="list-style-type: none"><li>• <a href="http://www.chem.agilent.com/scripts/cag_firmware.asp">http://www.chem.agilent.com/scripts/cag_firmware.asp</a>.</li></ul></li><li>2 Load the firmware into the pump as described in the documentation.</li></ol>

### NOTE

The G1312B Binary Pump SL requires firmware revision A.06.02 or above (main and resident).



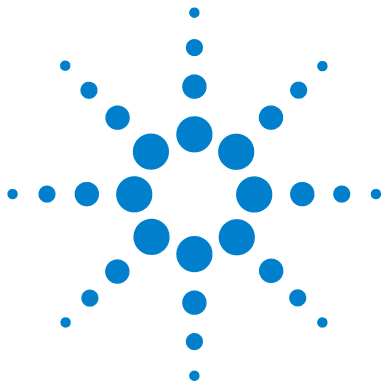

## 10 Parts and Materials for Maintenance

Bottle Head Assembly	146
Hydraulic Path with Solvent Selection Valve	148
Hydraulic Path without Solvent Selection Valve	150
Pump-Head Assembly SL	152
Outlet Ball Valve Assembly	154
Purge Valve Assembly	155
Active Inlet Valve Assembly	156
Accessory Kit G1312-68725	157
Active Seal Wash Option G1312-68721	158
G1316B SL Capillary System Kit	159

This chapter lists all parts and tools that are required for maintenance and simple repairs.



## Bottle Head Assembly

**Table 15** Bottle-Head Assembly Parts

<b>Item</b>	<b>Description</b>	<b>Part Number</b>
1	Bottle amber, volume 1L	<b>9301-1450</b>
2	Bottle transparent, volume 1L	<b>9301-1420</b>
3	Bottle-head assembly, complete (includes 1 ea. of parts 4 - 8)	<b>G1311-60003</b>
4	Ferrules with lock ring	<b>5063-6598 (10x)</b>
5	Tube screw	<b>5063-6599 (10x)</b>
6	Solvent tubing, 5 m	<b>5062-2483</b>
7	Inlet filter adapter (pack of 4)	<b>5062-8517</b>
8	Solvent inlet filter, 20 $\mu$ m	<b>5041-2168</b>

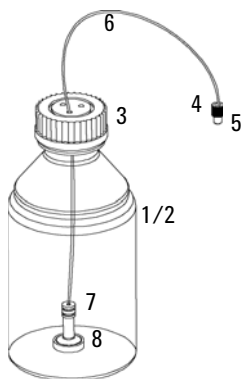

**Figure 39** Bottle-Head Assembly Parts

## Hydraulic Path with Solvent Selection Valve

**Table 16** Hydraulic Path with Solvent Selection Valve

<b>Item</b>	<b>Description</b>	<b>Part Number</b>
1	Solvent tubing, (kit of 4 ea. degasser to pump SSV)	<b>G1322-67300</b>
2	Solvent selection valve (SSV) (PN gives half of a complete solvent selection block)	<b>G1312-60000</b>
	Blank Plug for SSV	<b>5041-8365</b>
3	Connecting tube (solvent selection valve to active inlet valve)	<b>G1311-67304</b>
	Plug for unused SSV ports (not shown)	<b>5041-8365</b>
4	Active inlet valve, see <a href="#">“Active Inlet Valve Assembly”</a> on page 156	
5	Pump head, see <a href="#">“Pump-Head Assembly SL”</a> on page 152	
6	Outlet ball valve, see <a href="#">“Outlet Ball Valve Assembly”</a> on page 154	
7	Absorber capillary	<b>G1312-87300</b>
8	Mixing capillary	<b>G1312-67302</b>
9	Restriction capillary (mixing capillary to pressure sensor)	<b>G1312-87301</b>
10	Pressure sensor	see Service Manual
11	Capillary SSL, 0.17 x 150 mm (pressure sensor to damper)	<b>G1312-87305</b>
12	Damper	see Service Manual
13	Solvent mixer	<b>G1312-87330</b>
14	Capillary SSL, 0.17 x 105 mm (connections to solvent mixer)	<b>G1312-87306</b>
	Bracket for solvent mixer	<b>G1312-04100</b>
15	Purge valve SL, see <a href="#">“Purge Valve Assembly”</a> on page 155	
	Peristaltic pump cartridge (silicone tubing), not shown	<b>5042-8507</b>
	Tubing, 1 mm ID, 3 mm OD, silicone, 5 m, for seal wash option	<b>5065-9978</b>

**Table 16** Hydraulic Path with Solvent Selection Valve

Item	Description	Part Number
16	Capillary, pump to injector device (0.17 x 400 mm, SSL)	<b>G1312-87303</b>
	Capillary, pump to thermostatable autosampler (0.17 x 700 mm, SSL)	<b>G1312-87304</b>
17	Waste tube, 5 m	<b>5062-2461</b>

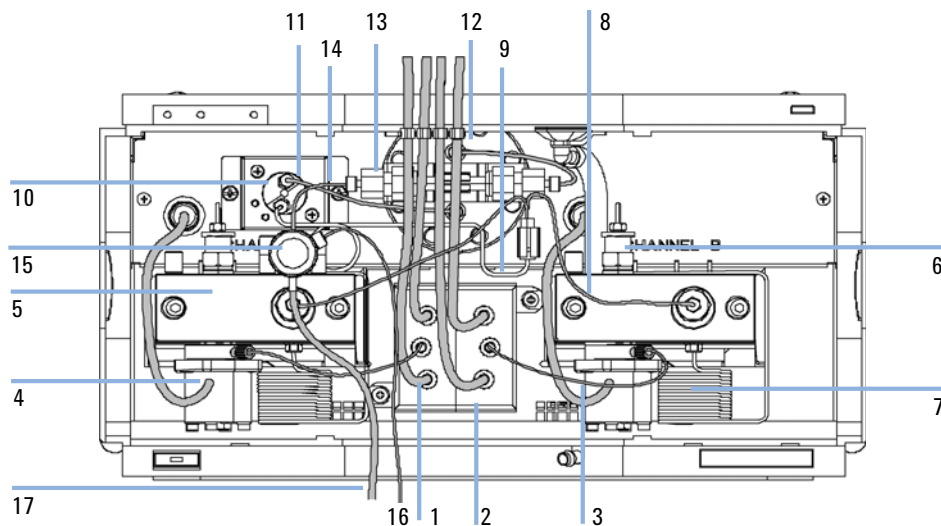
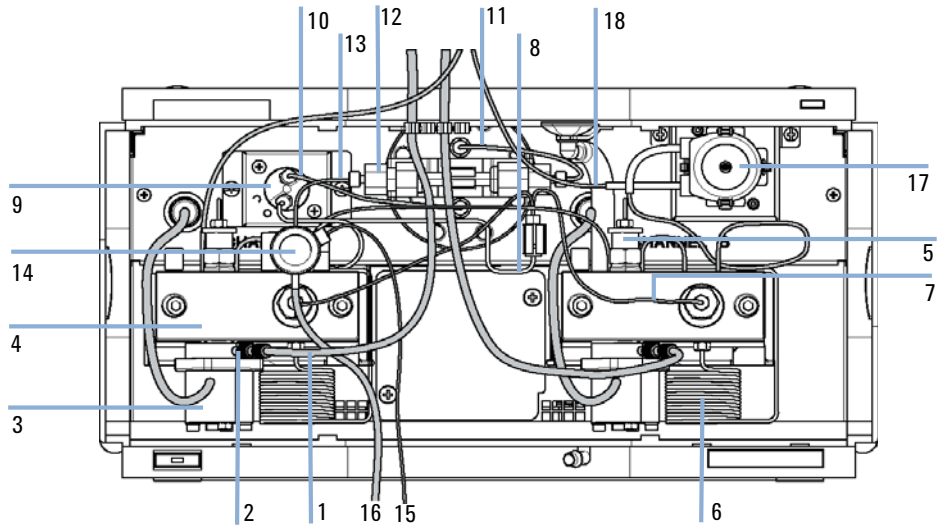

**Figure 40** Hydraulic Path with Solvent Selection Valve

## Hydraulic Path without Solvent Selection Valve

**Table 17** Hydraulic Path without Solvent Selection Valve, With Active Seal Wash

<b>Item</b>	<b>Description</b>	<b>Part Number</b>
1	Solvent tubing, (kit of 4 ea. degasser to pump SSV)	<b>G1322-67300</b>
2	PEEK adapter 1/4-28 to 10-32	<b>0100-1847</b>
3	Active inlet valve, see <a href="#">“Active Inlet Valve Assembly”</a> on page 156	
4	Pump head, see <a href="#">“Pump-Head Assembly SL”</a> on page 152	
5	Outlet ball valve, see <a href="#">“Outlet Ball Valve Assembly”</a> on page 154	
6	Absorber capillary	<b>G1312-87300</b>
7	Mixing capillary	<b>G1312-67302</b>
8	Restriction capillary (mixing capillary to pressure sensor)	<b>G1312-87301</b>
9	Pressure sensor	see Service Manual
10	Capillary SSL, 0.17 x 150 mm (pressure sensor to damper)	<b>G1312-87305</b>
11	Damper	see Service Manual
12	Solvent mixer	<b>G1312-87330</b>
13	Capillary SSL, 0.17 x 105 mm (connections to solvent mixer)	<b>G1312-87306</b>
	Bracket for solvent mixer	<b>G1312-04100</b>
14	Purge valve SL, see <a href="#">“Purge Valve Assembly”</a> on page 155	
15	Capillary, pump to injector device (0.17 x 400 mm, SSL)	<b>G1312-87303</b>
	Capillary, pump to thermostatable autosampler (0.17 x 700 mm, SSL)	<b>G1312-87304</b>
16	Waste tube, 5 m	<b>5062-2461</b>
17	Peristaltic pump (silicone tubing)	<b>5042-8507</b>
18	Tubing, 1 mm ID, 3 mm OD, silicone, 5 m, for seal wash option	<b>5065-9978</b>



**Figure 41** Hydraulic Path with Solvent Selection Valve, with Active Seal Wash

## Pump-Head Assembly SL

**Table 18** Pump-Head Assembly with Seal Wash

<b>Item</b>	<b>Description</b>	<b>Part Number</b>
	Complete assembly, included items marked with (*)	<b>G1312-60045</b>
1*	Sapphire piston Lubricant, black (apply to piston base)	<b>5063-6586</b> <b>79841-65501</b>
2*	Plunger housing (including springs)	<b>G1311-60002</b>
3*	Support ring (includes wash seal)	<b>5062-2465</b>
4*	Wash seal	<b>0905-1175</b>
5	Tubing for seal wash option (not shown) 1 mm ID, 3 mm OD, silicone, 5 m,	<b>5065-9978</b>
6*	Gasket, seal wash (pack of 6)	<b>5062-2484</b>
7*	Seal keeper (pack of 2)	<b>5042-8586</b>
8*	Seal (pack of 2) or Seal (pack of 2), for normal phase applications (optional)	<b>5063-6589</b> <b>0905-1420</b>
9	Absorber capillary	<b>G1312-87300</b>
10*	Pump chamber housing	<b>G1311-25200</b>
11	Active inlet valve body (without cartridge) Replacement cartridge for active inlet valve SL	<b>G1312-60025</b> <b>G1312-60020</b>
12*	Screw, purge-valve holder	<b>0515-0175</b>
13	Purge-valve holder	<b>G1312-23200</b>
14	Outlet ball valve SL	<b>G1312-60022</b>
15*	Screw lock	<b>5042-1303</b>
16	Adapter	<b>G1312-23201</b>
17	Purge valve assembly SL	<b>G1312-60023</b>
18	Screw M5 60 mm lg	<b>0515-2118</b>



**Table 18** Pump-Head Assembly with Seal Wash

Item	Description	Part Number
19	Seal wash pump assembly (includes item 20)	5065-9953
20	Peristaltic pump (silicone tubing)	5042-8507

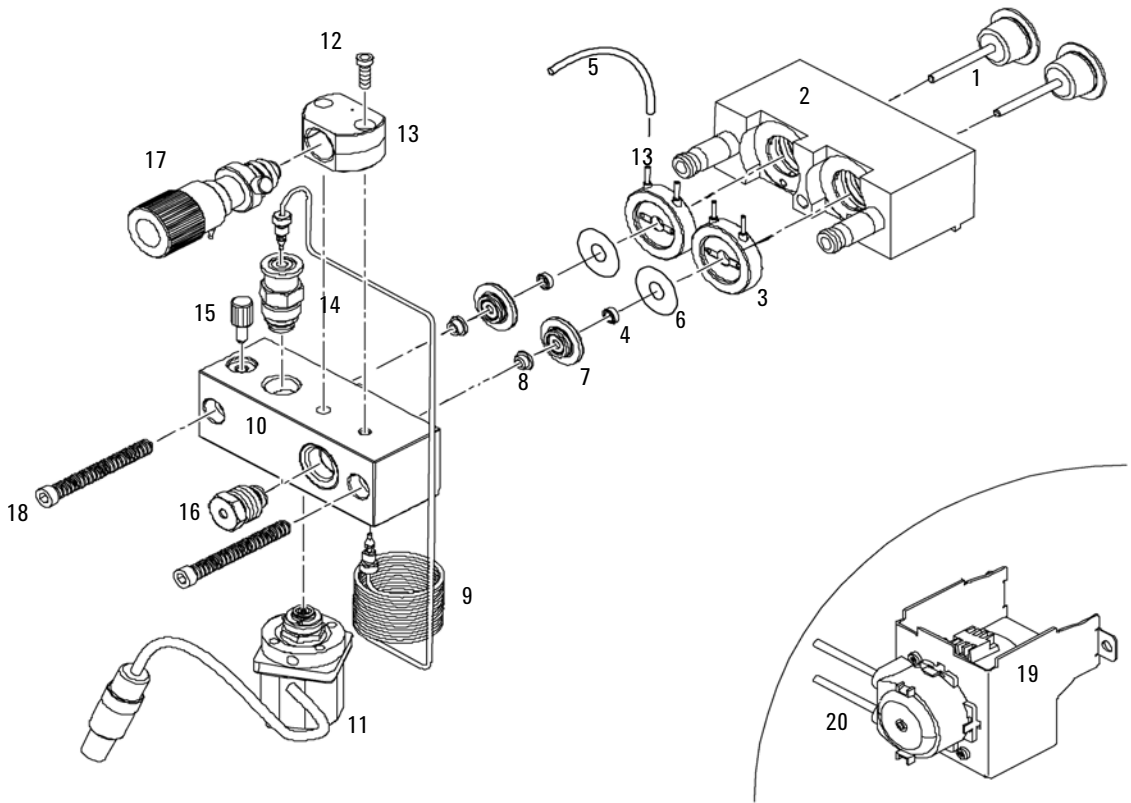
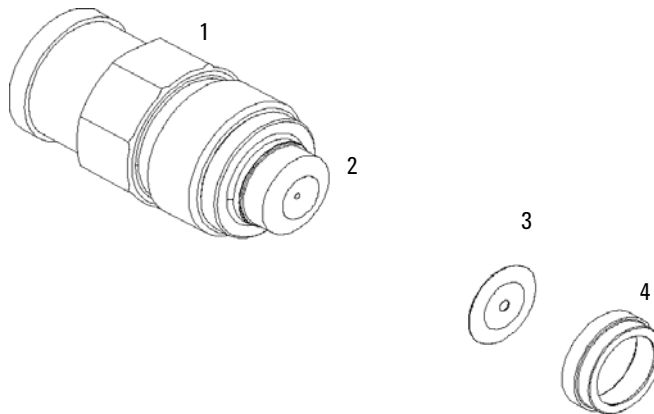

**Figure 42** Pump Head Assembly with Seal Wash Option

## Outlet Ball Valve Assembly

**Table 19** Outlet Ball Valve Assembly

Item	Description	Part Number
	Outlet ball valve SL — complete assembly	<b>G1312-60022</b>
1	Housing screw	<b>01018-22410</b>
2	Outlet valve cartridge	No part number
3	Gold seal, outlet	<b>5001-3707</b>
4	Cap (pack of 4, reorder number)	<b>5062-2485</b>

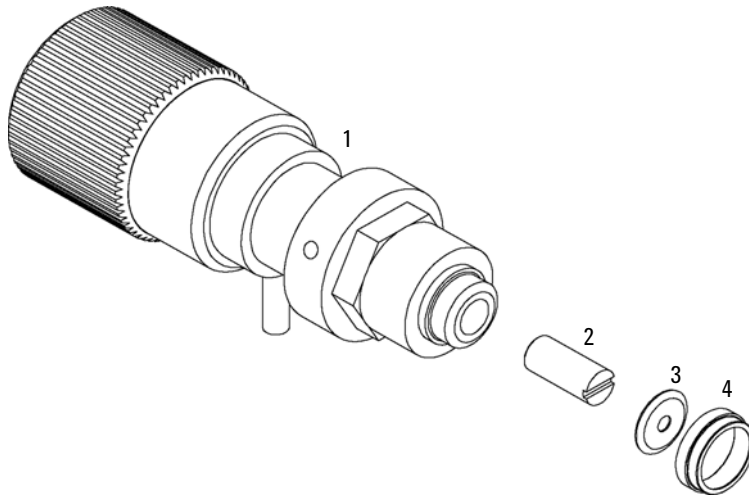

**Figure 43** Outlet Ball Valve Assembly

# Purge Valve Assembly

**Table 20** Purge-Valve Assembly

Item	Description	Part Number
	Purge valve SL — complete assembly	<b>G1312-60023</b>
1	Valve body	No part number
2	PTFE frit (pack of 5)	<b>01018-22707</b>
3	Gold seal	<b>5001-3707</b>
4	Cap (pack of 4, reorder number)	<b>5062-2485</b>

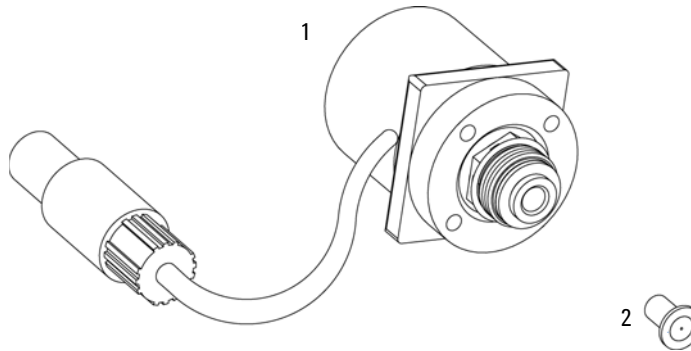

**Figure 44** Purge Valve

## Active Inlet Valve Assembly

**Table 21** Active Inlet Valve Assembly

Item	Description	Part Number
1	Active inlet valve body	G1312-60025
2	Valve cartridge SL	G1312-60020



**Figure 45** Active Inlet Valve Assembly

## Accessory Kit G1312-68725

**Table 22** Accessory Kit G1312-68725

<b>Description</b>	<b>Part Number</b>
Insert tool for wash seals	<b>01018-23702</b>
PTFE Frit (pack of 5)	<b>01018-22707</b>
PTFE tubing, 1.45 mm ID, length 2 m, purge valve to waste	not orderable
PTFE tubing, 1.45 mm ID, reorder (gives 5 m)	<b>5062-2461</b>
Waste tubing assembly	not orderable
Corrugated waste tube, reorder, (gives 5 m)	<b>5062-2463</b>
Hex key 4 mm, 15 cm long T-handle	<b>8710-2392</b>
Wrench 1/4 – 5/16 inch	<b>8710-0510</b>
Hex key 3 mm, 12 cm long	<b>8710-2411</b>
Wrench, 14 mm	<b>8710-1924</b>
Hex driver open, 1/4 inch	<b>5023-0240</b>
CAN cable, 1 m long	<b>5181-1519</b>
Capillary, pump to sampler, 400 mm lg, id 0.17 mm	<b>G1312-87303</b>
Capillary, pump to thermostatted sampler, 700 mm lg, id 0.17 mm	<b>G1312-87304</b>

## Active Seal Wash Option G1312-68721

**Table 23** Active Seal Wash Option Kit for Binary Pump SL

<b>Description</b>	<b>Part Number</b>
Seal wash pump assembly (includes peristaltic pump and pump motor)	<b>5065-9953</b>
Peristaltic pump, silicone tubing	<b>5042-8507</b>
Secondary seal (4 ea.)	<b>0905-1175</b>
Gasket, wash seal (4 ea) (reorder gives pack of 6)	<b>5062-2484</b>
Silicone rubber tubing 1mm I.D. (3m)	<b>0890-1764</b>
Seal (2 packs of 2 for Binary Pump SL)	<b>5063-6589</b>
Seal insertion tool	<b>01018-2370</b>

## G1316B SL Capillary System Kit

**Table 24** G1316B SL Capillary System Kit G1316-68744

Item	Description	Part Number
*	Carrier for Heater or Cooling Devices, QTY=2	<b>G1316-83200</b>
*	High Temperature Heater (0.12 mm i.d. 1.6 µl), QTY=1	<b>G1316-80002</b>
*	High Temperature Heater (0.12 mm i.d. 1.6 µl), QTY=1	<b>G1316-80003</b>
*	Cooler (0.12 mm i.d. 1.5 µl), QTY=1	<b>G1316-80004</b>
	Capillary System Kit, see <a href="#">Table 25</a> on page 159 for details	<b>G1316-68716</b>

For items \* see also “Heater and Cooler Devices for G1316B” in the G1316B User Manual.

**Table 25** Capillary System Kit G1316-68716

Item	Description	Part Number
	Seat Capillary 100 mm x 0.12 mm, 0.8 OD	<b>G1367-87303</b>
	DAD Heat Exchanger Capillary 310 mm x 0.12 mm	<b>G1315-87339</b>
	SST Capillary 340 mm x 0.12 mm, m/m	<b>G1316-87319</b>
	SST Capillary 300 mm x 0.12 mm, m/m	<b>G1316-87318</b>
	SST Capillary 210 mm x 0.12 mm, m/m	<b>G1316-87317</b>
	SST Capillary 170 mm x 0.12 mm, m/m	<b>G1316-87316</b>
	SST Capillary 130 mm x 0.12 mm, m/f	<b>G1316-87315</b>
	SST Capillary 90 mm x 0.12 mm, m/f	<b>G1316-87314</b>
	SST Capillary 70 mm x 0.12 mm, m/f	<b>G1316-87313</b>
	SST Capillary 50 mm x 0.12 mm, m/f	<b>G1316-87312</b>
	SST Capillary 170 mm x 0.12 mm, m/f	<b>G1316-87327</b>
	SST Capillary 500 mm x 0.12 mm, m/m	<b>G1316-87309</b>
	SST Capillary 500 mm x 0.12 mm, m/m	<b>G1315-87307</b>

**10 Parts and Materials for Maintenance**  
G1316B SL Capillary System Kit





## 11 Identifying Cables

Cable Overview	162
Analog Cables	164
Remote Cables	167
BCD Cables	173
External Contact Cable	175
CAN/LAN Cables	176
Auxiliary Cable	177
RS-232 Cables	178

This chapter provides information on cables.



## Cable Overview

**NOTE**

Never use cables other than the ones supplied by Agilent Technologies to ensure proper functionality and compliance with safety or EMC regulations.

Type	Description	Part Number
Analog cables	3390/2/3 integrators	<b>01040-60101</b>
	3394/6 integrators	<b>35900-60750</b>
	Agilent <b>35900A</b> A/D converter	<b>35900-60750</b>
	General purpose (spade lugs)	<b>01046-60105</b>
Remote cables	3390 integrator	<b>01046-60203</b>
	3392/3 integrators	<b>01046-60206</b>
	3394 integrator	<b>01046-60210</b>
	3396A (Series I) integrator	<b>03394-60600</b>
	3396 Series II / 3395A integrator, see details in section <a href="#">"Remote Cables"</a> on page 167	
	3396 Series III / 3395B integrator	<b>03396-61010</b>
	HP 1050 modules / HP 1046A FLD	<b>5061-3378</b>
	HP 1046A FLD	<b>5061-3378</b>
	Agilent <b>35900A</b> A/D converter	<b>5061-3378</b>
	HP 1040 diode-array detector	<b>01046-60202</b>
BCD cables	HP 1090 liquid chromatographs	<b>01046-60202</b>
	Signal distribution module	<b>01046-60202</b>
	3396 integrator	<b>03396-60560</b>
	General purpose (spade Lugs)	<b>G1351-81600</b>
Auxiliary	Agilent 1100 Series vacuum degasser	<b>G1322-61600</b>

<b>Type</b>	<b>Description</b>	<b>Part Number</b>
<i>CAN cables</i>	Agilent 1100/1200 module to module, 0.5m lg	<b>5181-1516</b>
	Agilent 1100/1200 module to module, 1m lg	<b>5181-1519</b>
<i>External contacts</i>	Agilent 1100/1200 Series interface board to general purpose	<b>G1103-61611</b>
<i>GPIB cable</i>	Agilent 1100/1200 module to ChemStation, 1 m	<b>10833A</b>
	Agilent 1100/1200 module to ChemStation, 2 m	<b>10833B</b>
<i>RS-232 cable</i>	Agilent 1100/1200 module to a computer This kit contains a 9-pin female to 9-pin female Null Modem (printer) cable and one adapter.	<b>34398A</b>
<i>LAN cable</i>	Twisted pair cross over LAN cable, (shielded 3m long) (for point to point connection)	<b>5023-0203</b>
	Twisted pair cross over LAN cable, (shielded 7m long) (for point to point connection)	<b>5023-0202</b>

## Analog Cables

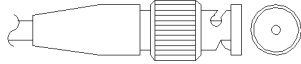

One end of these cables provides a BNC connector to be connected to Agilent 1100/1200 Series modules. The other end depends on the instrument to which connection is being made.

### Agilent 1100/1200 to 3390/2/3 Integrators

Connector 01040-60101	Pin 3390/2/3	Pin Agilent 1100/1200	Signal Name
	1	Shield	Ground
	2		Not connected
	3	Center	Signal +
	4		Connected to pin 6
	5	Shield	Analog -
	6		Connected to pin 4
	7		Key
	8		Not connected

### Agilent 1100/1200 to 3394/6 Integrators

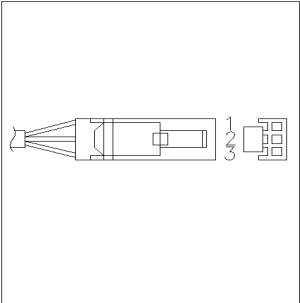
Connector 35900-60750	Pin 3 394/6	Pin Agilent 1100/1200	Signal Name
	1		Not connected
	2	Shield	Analog -
	3	Center	Analog +

### Agilent 1100/1200 to BNC Connector

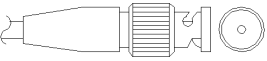
Connector 8120-1840	Pin BNC	Pin Agilent 1100/1200	Signal Name
	Shield	Shield	Analog -
	Center	Center	Analog +

## 11 Identifying Cables

### Analog Cables

#### Agilent 1100/1200 to General Purpose

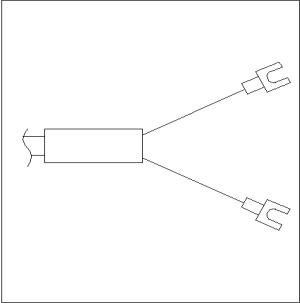
Connector 01046-60105	Pin 3394/6	Pin Agilent 1100/1200	Signal Name
	1		Not connected
	2	Black	Analog -
	3	Red	Analog +

## Remote Cables



One end of these cables provides a Agilent Technologies APG (Analytical Products Group) remote connector to be connected to Agilent 1100/1200 Series modules. The other end depends on the instrument to be connected to.

### Agilent 1100/1200 to 3390 Integrators

Connector 01046-60203	Pin 3390	Pin Agilent 1100/1200	Signal Name	Active (TTL)
	2	1 - White	Digital ground	
	NC	2 - Brown	Prepare run	Low
	7	3 - Gray	Start	Low
	NC	4 - Blue	Shut down	Low
	NC	5 - Pink	Not connected	
	NC	6 - Yellow	Power on	High
	NC	7 - Red	Ready	High
	NC	8 - Green	Stop	Low
	NC	9 - Black	Start request	Low

## 11 Identifying Cables

### Remote Cables

### Agilent 1100/1200 to 3392/3 Integrators

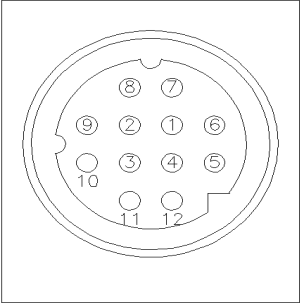
Connector 01046-60206	Pin 3392/3	Pin Agilent 1100/1200	Signal Name	Active (TTL)
	3	1 - White	Digital ground	
	NC	2 - Brown	Prepare run	Low
	11	3 - Gray	Start	Low
	NC	4 - Blue	Shut down	Low
	NC	5 - Pink	Not connected	
	NC	6 - Yellow	Power on	High
	9	7 - Red	Ready	High
	1	8 - Green	Stop	Low
	NC	9 - Black	Start request	Low

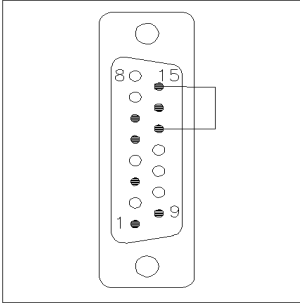

### Agilent 1100/1200 to 3394 Integrators

Connector 01046-60210	Pin 3394	Pin Agilent 1100/1200	Signal Name	Active (TTL)
	9	1 - White	Digital ground	
	NC	2 - Brown	Prepare run	Low
	3	3 - Gray	Start	Low
	NC	4 - Blue	Shut down	Low
	NC	5 - Pink	Not connected	
	NC	6 - Yellow	Power on	High
	5,14	7 - Red	Ready	High
	6	8 - Green	Stop	Low
	1	9 - Black	Start request	Low
	13, 15		Not connected	

**NOTE**

START and STOP are connected via diodes to pin 3 of the 3394 connector.

## 11 Identifying Cables

### Remote Cables

#### Agilent 1100/1200 to 3396A Integrators

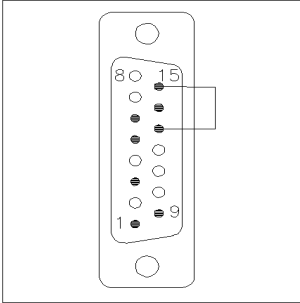
Connector 03394-60600	Pin 3394	Pin Agilent 1100/1200	Signal Name	Active (TTL)
	9	1 - White	Digital ground	
	NC	2 - Brown	Prepare run	Low
	3	3 - Gray	Start	Low
	NC	4 - Blue	Shut down	Low
	NC	5 - Pink	Not connected	
	NC	6 - Yellow	Power on	High
	5,14	7 - Red	Ready	High
	1	8 - Green	Stop	Low
	NC	9 - Black	Start request	Low
	13, 15		Not connected	

#### Agilent 1100/1200 to 3396 Series II / 3395A Integrators

Use the cable **part number: 03394-60600** and cut pin #5 on the integrator side. Otherwise the integrator prints START; not ready.

### Agilent 1100/1200 to 3396 Series III / 3395B Integrators

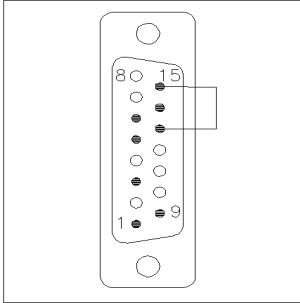
Connector 03396-61010	Pin 33XX	Pin Agilent 1100/1200	Signal Name	Active (TTL)
	9	1 - White	Digital ground	
	NC	2 - Brown	Prepare run	Low
	3	3 - Gray	Start	Low
	NC	4 - Blue	Shut down	Low
	NC	5 - Pink	Not connected	
	NC	6 - Yellow	Power on	High
	14	7 - Red	Ready	High
	4	8 - Green	Stop	Low
	NC	9 - Black	Start request	Low
	13, 15		Not connected	

### Agilent 1100/1200 to HP 1050, HP 1046A or Agilent 35900 A/D Converters

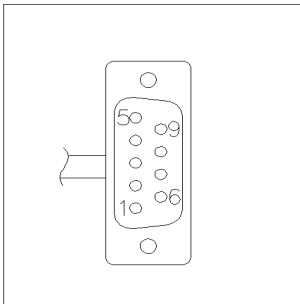
Connector 5061-3378	Pin HP 1050/....	Pin Agilent 1100/1200	Signal Name	Active (TTL)
	1 - White	1 - White	Digital ground	
	2 - Brown	2 - Brown	Prepare run	Low
	3 - Gray	3 - Gray	Start	Low
	4 - Blue	4 - Blue	Shut down	Low
	5 - Pink	5 - Pink	Not connected	
	6 - Yellow	6 - Yellow	Power on	High
	7 - Red	7 - Red	Ready	High
	8 - Green	8 - Green	Stop	Low
	9 - Black	9 - Black	Start request	Low

## 11 Identifying Cables

### Remote Cables

#### Agilent 1100/1200 to HP 1090 LC or Signal Distribution Module

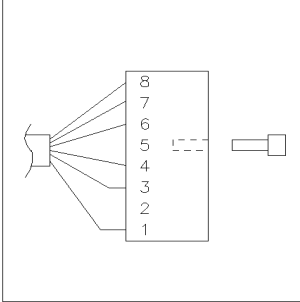
Connector 01046-60202	Pin HP 1090	Pin Agilent 1100/1200	Signal Name	Active (TTL)
	1	1 - White	Digital ground	
	NC	2 - Brown	Prepare run	Low
	4	3 - Gray	Start	Low
	7	4 - Blue	Shut down	Low
	8	5 - Pink	Not connected	
	NC	6 - Yellow	Power on	High
	3	7 - Red	Ready	High
	6	8 - Green	Stop	Low
	NC	9 - Black	Start request	Low

#### Agilent 1100/1200 to General Purpose

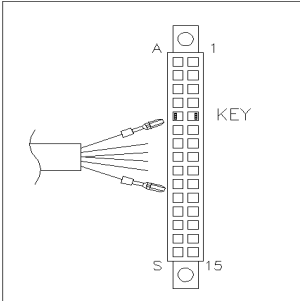
Connector 01046-60201	Pin Universal	Pin Agilent 1100/1200	Signal Name	Active (TTL)
		1 - White	Digital ground	
		2 - Brown	Prepare run	Low
		3 - Gray	Start	Low
		4 - Blue	Shut down	Low
		5 - Pink	Not connected	
		6 - Yellow	Power on	High
		7 - Red	Ready	High
		8 - Green	Stop	Low
		9 - Black	Start request	Low

## BCD Cables



One end of these cables provides a 15-pin BCD connector to be connected to the Agilent 1200 Series modules. The other end depends on the instrument to be connected to

### Agilent 1200 to General Purpose

Connector G1351-81600	Wire Color	Pin Agilent 1200	Signal Name	BCD Digit
	Green	1	BCD 5	20
	Violet	2	BCD 7	80
	Blue	3	BCD 6	40
	Yellow	4	BCD 4	10
	Black	5	BCD 0	1
	Orange	6	BCD 3	8
	Red	7	BCD 2	4
	Brown	8	BCD 1	2
	Gray	9	Digital ground	Gray
	Gray/pink	10	BCD 11	800
	Red/blue	11	BCD 10	400
	White/green	12	BCD 9	200
	Brown/green	13	BCD 8	100
	not connected	14		
	not connected	15	+ 5 V	Low

## 11 Identifying Cables

### BCD Cables

#### Agilent 1200 to 3396 Integrators

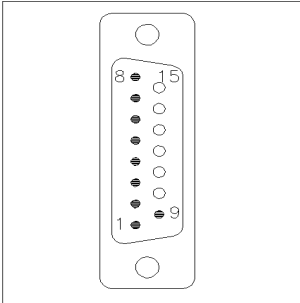
Connector 03396-60560	Pin 3392/3	Pin Agilent 1200	Signal Name	BCD Digit
	1	1	BCD 5	20
	2	2	BCD 7	80
	3	3	BCD 6	40
	4	4	BCD 4	10
	5	5	BCD0	1
	6	6	BCD 3	8
	7	7	BCD 2	4
	8	8	BCD 1	2
	9	9	Digital ground	
	NC	15	+ 5 V	Low

# External Contact Cable

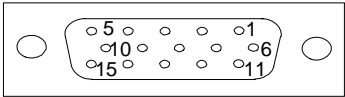

One end of this cable provides a 15-pin plug to be connected to Agilent 1200 Series module’s interface board. The other end is for general purpose.

## Agilent 1200 Series Interface Board to general purposes

Connector G1103-61611	Color	Pin Agilent 1200	Signal Name
	White	1	EXT 1
	Brown	2	EXT 1
	Green	3	EXT 2
	Yellow	4	EXT 2
	Grey	5	EXT 3
	Pink	6	EXT 3
	Blue	7	EXT 4
	Red	8	EXT 4
	Black	9	Not connected
	Violet	10	Not connected
	Grey/pink	11	Not connected
	Red/blue	12	Not connected
	White/green	13	Not connected
	Brown/green	14	Not connected
	White/yellow	15	Not connected

## CAN/LAN Cables

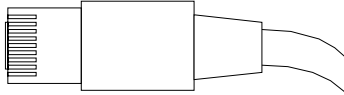

Both ends of this cable provide a modular plug to be connected to Agilent 1200 Series module's CAN or LAN connectors.

### CAN Cables

Agilent 1200 module to module, 0.5 m	<b>5181-1516</b>
Agilent 1200 module to module, 1 m	<b>5181-1519</b>
Agilent 1200 module to control module	<b>G1323-81600</b>

### LAN Cables

<b>Description</b>	<b>Part number</b>
Cross-over network cable (shielded, 3 m long), (for point to point connection)	<b>5023-0203</b>
Twisted pair network cable (shielded, 7 m long) (for hub connections)	<b>5023-0202</b>



## Auxiliary Cable

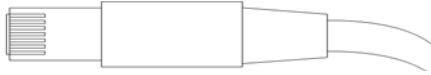

One end of this cable provides a modular plug to be connected to the Agilent 1100 Series vacuum degasser. The other end is for general purpose.

### Agilent 1100 Series Degasser to general purposes

Connector G1322-81600	Color	Pin Agilent 1100	Signal Name
	White	1	Ground
	Brown	2	Pressure signal
	Green	3	
	Yellow	4	
	Grey	5	DC + 5 V IN
	Pink	6	Vent

## RS-232 Cables

Description	Part number
RS-232 cable, instrument to PC, 9-to-9 pin (female) This cable has special pin-out, and is not compatible with connecting printers and plotters.	<b>24542U</b> <b>G1530-60600</b>
RS-232 cable kit, 9-to-9 pin (female) and one adapter 9-pin (male) 25-pin female. Suited for instrument to PC.	<b>34398A</b>
Cable Printer Serial & Parallel, is a SUB-D 9 pin female vs. Centronics connector on the other end (NOT FOR FW UPDATE).	<b>5181-1529</b>
This kit contains a 9-pin female to 9-pin female Null Modem (printer) cable and one adapter. Use the cable and adapter to connect Agilent Technologies instruments with 9-pin male RS-232 connectors to most PCs or printers.	<b>34398A</b>



## 12 Appendix

General Safety Information	180
The Waste Electrical and Electronic Equipment Directive	184
Lithium Batteries Information	185
Radio Interference	186
Sound Emission	187
Solvent Information	188
Agilent Technologies on Internet	190

This appendix provides general safety and environmental information.



## General Safety Information

### General Safety Information

The following general safety precautions must be observed during all phases of operation, service, and repair of this instrument. Failure to comply with these precautions or with specific warnings elsewhere in this manual violates safety standards of design, manufacture, and intended use of the instrument. Agilent Technologies assumes no liability for the customer's failure to comply with these requirements.

#### **WARNING**

**Ensure the proper usage of the equipment.**

**The protection provided by the equipment may be impaired.**

→ The operator of this instrument is advised to use the equipment in a manner as specified in this manual.

---

### Safety Standards

This is a Safety Class I instrument (provided with terminal for protective earthing) and has been manufactured and tested according to international safety standards.

## Operation

Before applying power, comply with the installation section. Additionally the following must be observed.

Do not remove instrument covers when operating. Before the instrument is switched on, all protective earth terminals, extension cords, auto-transformers, and devices connected to it must be connected to a protective earth via a ground socket. Any interruption of the protective earth grounding will cause a potential shock hazard that could result in serious personal injury. Whenever it is likely that the protection has been impaired, the instrument must be made inoperative and be secured against any intended operation.

Make sure that only fuses with the required rated current and of the specified type (normal blow, time delay, and so on) are used for replacement. The use of repaired fuses and the short-circuiting of fuse holders must be avoided.

Some adjustments described in the manual, are made with power supplied to the instrument, and protective covers removed. Energy available at many points may, if contacted, result in personal injury.

Any adjustment, maintenance, and repair of the opened instrument under voltage should be avoided whenever possible. When inevitable, this has to be carried out by a skilled person who is aware of the hazard involved. Do not attempt internal service or adjustment unless another person, capable of rendering first aid and resuscitation, is present. Do not replace components with power cable connected.

Do not operate the instrument in the presence of flammable gases or fumes. Operation of any electrical instrument in such an environment constitutes a definite safety hazard.

Do not install substitute parts or make any unauthorized modification to the instrument.

## 12 Appendix





### General Safety Information

Capacitors inside the instrument may still be charged, even though the instrument has been disconnected from its source of supply. Dangerous voltages, capable of causing serious personal injury, are present in this instrument. Use extreme caution when handling, testing and adjusting.

When working with solvents please observe appropriate safety procedures (e.g. goggles, safety gloves and protective clothing) as described in the material handling and safety data sheet by the solvent vendor, especially when toxic or hazardous solvents are used.

## Safety Symbols

Table 26 Safety Symbols

Symbol	Description
	The apparatus is marked with this symbol when the user should refer to the instruction manual in order to protect risk of harm to the operator and to protect the apparatus against damage.
	Indicates dangerous voltages.
	Indicates a protected ground terminal.
	Indicates eye damage may result from directly viewing the light produced by the deuterium lamp used in this product.
	The apparatus is marked with this symbol when hot surfaces are available and the user should not touch it when heated up.

### WARNING

#### A WARNING

alerts you to situations that could cause physical injury or death.

- Do not proceed beyond a warning until you have fully understood and met the indicated conditions.

### CAUTION

#### A CAUTION

alerts you to situations that could cause loss of data, or damage of equipment.

- Do not proceed beyond a caution until you have fully understood and met the indicated conditions.

## The Waste Electrical and Electronic Equipment Directive

### Abstract

The Waste Electrical and Electronic Equipment (WEEE) Directive (2002/96/EC), adopted by EU Commission on 13 February 2003, is introducing producer responsibility on all electric and electronic appliances starting with 13 August 2005.

#### NOTE

This product complies with the WEEE Directive (2002/96/EC) marking requirements. The affixed label indicates that you must not discard this electrical/electronic product in domestic household waste.

Product Category:

With reference to the equipment types in the WEEE Directive Annex I, this product is classed as a "Monitoring and Control Instrumentation" product.

---



#### NOTE

Do not dispose off in domestic household waste

To return unwanted products, contact your local Agilent office, or see [www.agilent.com](http://www.agilent.com) for more information.

---



## Lithium Batteries Information

### **WARNING**

Lithium batteries may not be disposed-off into the domestic waste. Transportation of discharged Lithium batteries through carriers regulated by IATA/ICAO, ADR, RID, IMDG is not allowed.

**Danger of explosion if battery is incorrectly replaced.**

- Discharged Lithium batteries shall be disposed off locally according to national waste disposal regulations for batteries.
- Replace only with the same or equivalent type recommended by the equipment manufacturer.



### **WARNING**

**Lithiumbatteri - Eksplosionsfare ved fejlagtig håndtering.**

**Udskiftning må kun ske med batteri af samme fabrikat og type.**

- Lever det brugte batteri tilbage til leverandøren.

### **WARNING**

**Lithiumbatteri - Eksplosionsfare.**

**Ved udskiftning benyttes kun batteri som anbefalt av apparatfabrikanten.**

- Brukt batteri returneres apparatleverandøren.

### **NOTE**

Bij dit apparaat zijn batterijen geleverd. Wanneer deze leeg zijn, moet u ze niet weggooien maar inleveren als KCA.

## **Radio Interference**

Cables supplied by Agilent Technologies are screened to provide optimized protection against radio interference. All cables are in compliance with safety or EMC regulations.

### **Test and Measurement**

If test and measurement equipment is operated with unscreened cables, or used for measurements on open set-ups, the user has to assure that under operating conditions the radio interference limits are still met within the premises.

## Sound Emission

### Manufacturer's Declaration

This statement is provided to comply with the requirements of the German Sound Emission Directive of 18 January 1991.

This product has a sound pressure emission (at the operator position) < 70 dB.

- Sound Pressure  $L_p < 70$  dB (A)
- At Operator Position
- Normal Operation
- According to ISO 7779:1988/EN 27779/1991 (Type Test)

## Solvent Information

### Flow Cell

To protect optimal functionality of your flow-cell:

- Avoid the use of alkaline solutions (pH > 9.5) which can attack quartz and thus impair the optical properties of the flow cell.
- If the flow cell is transported while temperatures are below 5 degree C, it must be assured that the cell is filled with alcohol.
- Aqueous solvents in the flow cell can built up algae. Therefore do not leave aqueous solvents sitting in the flow cell. Add a small % of organic solvents (e.g. acetonitrile or methanol ~5%).

### Use of Solvents

Observe the following recommendations on the use of solvents.

- Always filter solvents through 0.4 µm filters, small particles can permanently block the capillaries and valves.
- Brown glass ware can avoid growth of algae.
- Avoid the use of the following steel-corrosive solvents:
  - Solutions of alkali halides and their respective acids (for example, lithium iodide, potassium chloride, and so on),
  - High concentrations of inorganic acids like sulfuric acid and nitric acid, especially at higher temperatures (if your chromatography method allows, replace by phosphoric acid or phosphate buffer which are less corrosive against stainless steel),
  - Halogenated solvents or mixtures which form radicals and/or acids, for example:

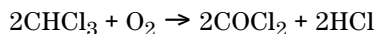

This reaction, in which stainless steel probably acts as a catalyst, occurs quickly with dried chloroform if the drying process removes the stabilizing alcohol,

## Solvent Information

- Chromatographic grade ethers, which can contain peroxides (for example, THF, dioxane, di-isopropylether) such ethers should be filtered through dry aluminium oxide which adsorbs the peroxides,
- Solvents containing strong complexing agents (e.g. EDTA),
- Mixtures of carbon tetrachloride with 2-propanol or THF.

## Agilent Technologies on Internet

For the latest information on products and services visit our worldwide web site on the Internet at:

<http://www.agilent.com>

Select Products/Chemical Analysis

It will provide also the latest firmware of the Agilent 1200 Series modules for download.

# Index

## A

absorber capillary 15  
 accessory kit 35  
 active inlet valve body 132  
 active inlet valve 156  
 active inlet valve 133, 135  
 Active seal wash, seal wash, active 8  
 active seal wash 77  
 adapter 50, 133, 135  
     inlet filter 146  
     syringe luer/barb 35  
 Agilent Diagnostic software 93  
 Agilent Lab Advisor software 93  
 Agilent Lab Advisor 93  
 Agilent LC Diagnostic SW 98  
 Agilent LC Diagnostic  
     CD-ROM 35  
 Agilent  
     on internet 190  
 algae 58, 74, 188, 188  
 alternative seal material 78  
 amber bottle 74  
 ambient operating temperature 29  
 ambient non-operating temperature 29  
 analog signal output 31  
 analog output 21  
 analog  
     cable 162, 164  
 APG remote connector 44  
 assembly  
     bottle head 146  
 AUTO mode 20  
 AUTO, pump stroke 13

auxiliary  
     cable 162, 177

## B

ball-screw drive 14  
 battery  
     safety information 185  
 BCD  
     board 143  
     cable 162, 173  
     output 21  
 bench space 28  
 blank nut, 1/16 inch 98  
 bottle head assembly 146, 146  
 bottle head assembly 35  
     inlet filter adapter 146  
     solvent inlet filter 146  
     solvent tubing 146  
     tube screw 146  
 bottles  
     transparent 146  
 buffer application 59  
 buffer solutions 8

## C

cable  
     analog 162, 164  
     auxiliary 162, 177  
     BCD 162, 173  
     CAN 44, 176  
     external contact 175  
     external contacts 163  
     GPIB 163  
     interface 44  
     LAN 163, 176

    power 35  
     remote 162, 167  
     RS-232 163, 178

cables  
     overview 162  
 Calibration capillary assembly 35  
 CAN cable 44  
 CAN  
     bus 21  
     cable 176  
 capillary  
     absorber 15  
     calibration 35  
 CD-ROM  
     Agilent LC Diagnostic 35  
 cleaning 114  
 column  
     Eclipse XDB-C18, 4.6x50mm, 1.8um,  
     600bar 35  
     SB-C18,  
     2.1x50mm, 1.8um, 600bar 35  
     SB-C18, 4.6x50mm, 1.8um,  
     600bar 35  
 compensation, compressibility 30  
 composition precision 31  
 composition ripple 103  
 compressibility compensation 30, 83  
 compressibility calibration 103  
 condensation 28  
 configuration  
     low flow rates 58  
 connections  
     flow 46, 49  
 connector  
     APG remote 44

## Index

- RS-232C 21
  - control and data evaluation 31
  - cover parts 152
  - CSM board 23
- ### D
- damaged parts 35, 35
  - damaged packaging 34
  - damper
    - when to remove 80
  - data evaluation and control 31
  - delay volume 11, 16, 80
  - delivery checklist 35
  - design 9
  - Diagnostic software 93
  - dimensions 29
  - dual-piston in-series design 9
- ### E
- early maintenance feedback (EMF) 8
  - early maintenance feedback 70
  - Eclipse XDB-C18, 4.6x50mm, 1.8um, 600bar 35
  - electrical connections 21
  - electronic fuses 21
  - electronic waste 184
  - electronics 23
  - electrostatic discharge (ESD) 143
  - EMF counter 109
  - EMF counters
    - (maximum) limit 71
    - liquimeter 71
    - seal wear 71
  - EMF flag 71, 109
  - EMF counters
    - setting limits 72
    - usage 72
  - EMF limits 72
- EMF 8
  - environment 28
  - error messages
    - overpressure 98, 102, 104
  - ESD (electrostatic discharge) strap 115
  - exchange
    - active inlet valve 133
  - exchanging
    - active inlet valve 132, 133, 135
    - interface board 143
    - internal parts 144
    - outlet ball valve sieve 138
    - outlet ball valve sieve 132
    - outlet ball valve 132, 138
    - pistons 117, 127
    - pump seals 124
    - pump seals 117
    - purge valve frit 132, 132
    - purge valve 132, 132
    - solvent selection valve 141
    - wash seals 128
    - wash seals 117
  - external contact
    - cable 163, 175
  - external contacts 21
- ### F
- features
    - GLP 31
    - instrument layout 8
    - safety and maintenance 31
  - ferrules with lock ring 146
  - filters
    - algae 74
  - filter
    - solvent inlet filter 146
    - solvent inlet 58
  - Filters
    - prevent blockages 74
  - firmware
    - updates 144
  - flow connections 46, 49
  - flow precision 30
  - flow range 8
    - operational 30
    - setable 30
  - flow cell 188
    - solvent information 188
  - flow rate
    - minimum 58
  - foam parts 152
  - frequency range 29
  - frequency range 21
  - fuse 21
- ### G
- gas solubility 58
  - GPIB
    - cable 163
  - gradient formation 30
- ### H
- hexagonal key 4 mm 127, 128, 130
  - hexagonal key, 3 mm 121, 124, 127, 128, 130
  - hexagonal key, 4 mm 121, 124, 127, 128, 130
  - high-pressure mixing 8
  - hints for successful use 58
  - humidity 29
  - hydraulic path with solvent selection valve 148
  - hydraulic path without solvent selection valve 150
  - hydraulic system 30
- ### I
- initialization 15
  - injection precision 76



## Index

inlet filter adapter 146  
insert tool 128, 130  
installation  
    damaged packaging 34  
    environment 28  
    power cords 27  
interface board 143  
interface cable 44  
interfaces 22  
internet 190  
introduction to the pump 8

## K

kit  
    accessory 35

## L

laboratory bench 28  
LAN  
    cable 163, 176  
leak parts 152  
line frequency 29  
line voltage 29  
line frequency 21  
line voltage 21  
liquimeter 71, 109, 125  
lithium batteries 185

## M

main assemblies, overview 116  
maintenance procedures 108  
maintenance procedures 70  
maintenance  
    replacing firmware 144  
minimum flow rate 58  
missing parts 35  
mixer 9  
    when to remove 80

## N

non-operating altitude 29  
non-operating temperature 29

## O

operating Altitude 29  
operating temperature 29  
outlet ball valve 154  
outlet ball valve 132, 138  
overpressure error 98, 102, 104

## P

parts identification  
    cables 161  
parts  
    active inlet valve 156  
    bottle head assembly 146  
    cover 152  
    damaged 35, 35  
    foam 152  
    hydraulic path with solvent selection valve 148  
    hydraulic path without solvent selection valve 150  
    leak handling 152  
    missing 35  
    outlet ball valve 154  
    pump head assembly with seal wash 152  
    purge valve 155  
    sheet metal kit 152  
performance  
    specifications 30  
pH range 30  
physical specifications 29  
piston 14, 117, 127  
plunger 14  
power switch 43  
power consumption 29

power cable 35  
power consideration 26  
power cords 27  
pressure pulsation 13  
pressure range 78  
pressure test  
    results 102  
pressure pulsation 20, 84  
pressure ripple 103  
pressure  
    operating range 30  
    pulsation 30  
priming  
    with a pump 54  
PTFE frit 155  
PTFE frit 132, 132  
pulsation  
    pressure 13, 20  
pump head assembly with seal wash 152  
pump seals  
    alternative material 78  
    for normal phase solvents 78  
pump stroke  
    AUTO mode 13  
pump seals 58, 117  
purge valve 155  
purge valve 58, 132, 132

## R

radio interference 186  
reassembling the pump head 130  
recommended pH range 30  
remote connector 21  
remote  
    cable 162, 167  
remove damper and mixer 80  
removing the pump head 121  
repair procedures 117

## Index

- repairs
  - definition of 112
  - introduction 112
  - using the ESD strap 115
  - warnings and cautions 112
- replacing
  - firmware 144
- results
  - pressure test 99, 102
- ripple
  - composition 103
  - pressure 103
- RS-232
  - cable 163
- RS-232C
  - cable 178
  - connector 21
- S**
- safety class I 180
- safety information
  - lithium batteries 185
- safety
  - general information 180, 180
  - standards 29
  - symbols 183
- sapphire piston 14
- SB-C18, 4.6x50mm, 1.8um, 600bar 35
- SB-C18, 2.1x50mm, 1.8um, 600bar 35
- screwdriver pozidriv #1 121, 124, 127, 128, 130
- screwdriver pozidriv #1 141
- screwdriver, flat-head 128
- seal wash
  - wash solvent 77
  - when to use 77
- seal wear counter 109
- seal wear counter 125
- seal wear 71
- seals
  - alternative material 78
  - normal phase 78
- security lever 43
- setable flow range 30
- sheet metal kit 152
- sieve 132, 138
- simple repair procedures 117
- simple repairs
  - exchanging active inlet valve cartridge 132
  - exchanging AVI cartridge 132
- Site Requirements 25
- snap fastener 46
- snap fastener 49
- solubility, gas 58
- solvent cabinet 47
- solvent compressibility calibration 103, 104
- solvent filters
  - checking 75
  - cleaning 75
- solvent inlet filter 58, 146
- solvent selection valve 46
- solvent selection valve 8, 35, 141
- solvent bottles
  - amber 35, 74
  - transparent 146
- Solvent bottle
  - transparent 35
- solvent cabinet 35, 58
- solvent filters
  - algae 74
  - prevent blockages 74
- solvent information 188
- solvent tubing 146
- solvents 188
- sonic bath 138
- sound emission 187
- specification
  - physical 29
- specifications
  - analog signal output 31
  - communications 31
  - control and data evaluation 31
  - performance 30
- status
  - indicators 88
- stroke volume 13, 15, 20
- Syringe
  - adapter luer/barb 35
- T**
- test functions 88
- tests
  - pressure test results 99
  - running the pressure test 98
  - solvent compressibility calibration 103, 104
- tools
  - blank nut, 1/16 inch 98
  - hexagonal key 4 mm 127, 128, 130
  - screwdriver pozidriv #1 121, 124, 127, 128, 130
  - screwdriver pozidriv #1 141
  - wrench 1/4 - 5/16 inch 98, 118
  - wrench 1/4 inch, slitted socket 121
  - wrench 1/4 inch 124
  - wrench 14 mm 102, 104, 118, 133, 135, 138
- troubleshooting
  - error messages 88
  - status indicators 88
- tube screw 146
- tubing PTFE 146
- tweezers 118
- tools 118

## Index

### U

unpacking the pump 34  
User Manual 35

### V

vacuum degasser 31  
    when to use 76  
vacuum degasser 8, 58, 58  
    operational hints 76  
valve  
    active inlet valve cartridge 133  
    active inlet valve 133  
    active inlet valve, replacement 132  
    solvent selection 141  
variable reluctance motor 15  
variable stroke volume 13  
variable stroke volume 20  
voltage range 29  
voltage  
    range 21  
    selector 21

### W

wash seals 128  
wash seals 117  
wash solvent 77  
waste  
    electrical and electronic  
    equipment 184  
WEEE directive 184  
weight 29  
wrench 1/4 - 5/16 inch 98  
wrench 1/4 inch, slitted socket 121  
wrench 1/4 inch 124  
wrench 14 mm 102, 104, 118, 133,  
135, 138

## In This Book

This manual contains technical reference information about the Agilent 1200 Series Binary Pump SL. The manual describes the following:

- introduction to the pump
- theory of operation
- installation
- optimizing performance
- diagnostics and troubleshooting
- maintenance
- parts and materials
- specifications.

© Agilent Technologies 2005, 2007-2009

Printed in Germany  
02/09



G1312-90011



**Agilent Technologies**