

G5562A, G5563A Bravo Platform

Safety and Installation Guide

**For Research Use Only. Not for use in
diagnostic procedures.**

Original Instructions

Notices

© Agilent Technologies, Inc. 2017

No part of this manual may be reproduced in any form or by any means (including electronic storage and retrieval or translation into a foreign language) without prior agreement and written consent from Agilent Technologies, Inc. as governed by United States and international copyright laws.

User Guide Part Number

G5563-90002

Edition

Revision A., October 2017

Contact Information

Agilent Technologies Inc.
Automation Solutions
5301 Stevens Creek Blvd.
Santa Clara, CA 95051
USA

Technical Support: 1.800.979.4811 (US) or
+1.408.345.8011 (rest of world)
service.automation@agilent.com

Customer Service: 800-227-9770 (US and
Canada)

By country: <http://www.agilent.com/en-us/contact-us/page>

Documentation feedback:
documentation.automation@agilent.com

Web:
<http://www.agilent.com/en-us/products/automation-solutions>

Acknowledgements

Microsoft® and Windows® are either registered trademarks or trademarks of the Microsoft Corporation in the United States and other countries.

Warranty

The material contained in this document is provided “as is,” and is subject to being changed, without notice, in future editions. Further, to the maximum extent permitted by applicable law, Agilent disclaims all warranties, either express or implied, with regard to this manual and any information contained herein, including but not limited to the implied warranties of merchantability and fitness for a particular purpose. Agilent shall not be liable for errors or for incidental or consequential damages in connection with the furnishing, use, or performance of this document or of any information contained herein. Should Agilent and the user have a separate written agreement with warranty terms covering the material in this document that conflict with these terms, the warranty terms in the separate agreement shall control.

Technology Licenses

The hardware and/or software described in this document are furnished under a license and may be used or copied only in accordance with the terms of such license.

Restricted Rights Legend

If software is for use in the performance of a U.S. Government prime contract or sub-contract, Software is delivered and licensed as “Commercial computer software” as defined in DFAR 252.227-7014 (June 1995), or as a “commercial item” as defined in FAR 2.101(a) or as “Restricted computer software” as defined in FAR 52.227-19 (June 1987) or any equivalent agency regulation or contract clause. Use, duplication or disclosure of Software is subject to Agilent Technologies’ standard commercial license terms, and non-DOD Departments and Agencies of the U.S. Government will receive no greater than Restricted Rights as defined in FAR 52.227-19(c)(1-2) (June 1987). U.S. Government users will receive no greater than Limited Rights as defined in FAR 52.227-14

(June 1987) or DFAR 252.227-7015 (b)(2) (November 1995), as applicable in any technical data.

Safety Notices

 **A WARNING notice denotes a hazard. It calls attention to an operating procedure, practice, or the like that, if not correctly performed or adhered to, could result in personal injury or death. Do not proceed beyond a WARNING notice until the indicated conditions are fully understood and met.**

A **CAUTION** notice denotes a hazard. It calls attention to an operating procedure, practice, or the like that, if not correctly performed or adhered to, could result in damage to the product or loss of important data. Do not proceed beyond a **CAUTION** notice until the indicated conditions are fully understood and met.

Contents

Preface	v
About this guide	vi
Reporting problems	viii
1. Safety guidelines	1
General safety information	2
Safety and regulatory compliance	3
Emergency stops	5
Mechanical hazards	6
Ergonomics	9
Cut hazard	10
2. Installing the Bravo Platform	11
Installation workflow	12
Laboratory setup requirements	13
Installing the platepads	17
Connecting the Bravo Platform	18
Installing the liquid-handling head	22
Bravo light curtains and shields	29
Installing the Standard Light Curtain and shields	36
Installing the rear shield	45
Installing the dust cover	48
Starting up and shutting down	49

Contents



Preface

This preface contains the following topics:

- “About this guide” on page vi
- “Reporting problems” on page viii

About this guide

Who should read this guide

This user guide is for people with the following job roles:

Job role	Responsibilities
Installer	Unpacks, installs, and tests the device before it is used.
Integrator	Configures hardware and writes software.
Lab manager, administrator, or technician	<ul style="list-style-type: none">• Manages the automation system that contains the device• Develops the applications that are run on the system• Develops training materials and standard operating procedures for operators
Operator	Performs the daily production work on the device and solves routine problems.

What this guide covers

This guide describes the following for the G5562A, G5563A Bravo Platform:

- Potential safety hazards of the Bravo Platform and how to avoid them
For general safety information, see the [Automation Solutions Products General Safety Guide](#).
- Site requirements for the Bravo Platform
Use this information to plan the space for the Bravo Platform. Make sure your site meets the requirements outlined in this guide before installing the device.
- Installation instructions for the Bravo Platform and the safety equipment

What is new in this revision

Revision description	See...
Updated the regulatory compliance standards.	“Safety and regulatory compliance” on page 3
Revised the light curtain description to include both the Standard and Wraparound Light Curtains.	“Bravo light curtains and shields” on page 29
Added a topic to describe the new Bravo dust cover.	“Installing the dust cover” on page 48

Related user instructions

Use this guide in conjunction with the following:

- *Automation Solutions Products General Safety Guide*. Provides general safety information and describes potential safety hazards that you might encounter when using Agilent Automation Solutions products. A copy of this safety guide is included with your shipment.
- *Bravo Platform Unpacking Guide*. Describes how to unpack the Bravo device from the shipping container.
- *Bravo Platform User Guide*. Describes how to set up, operate, and maintain the Bravo Platform and accessories.
- *Pump Module User Guide*. Describes how to install the Pump Module.
- *VWorks Automation Control Setup Guide*. Explains how to define labware and labware classes, liquid classes, and pipetting techniques, and how to track and manage labware in storage.
- *VWorks Automation Control User Guide*. Explains how to create protocols, set task parameters, and run protocols.

Note: For instructions on how to install and set up the G5571A AssayMAP Bravo Platform, Agilent service engineers should see the *AssayMAP Bravo Platform Installation Guide*.

Where to find user information

The Agilent Automation Solutions user information is available in the following locations:

- *VWorks knowledge base*. The help system that contains information about all the Agilent Automation Solutions products is available from the Help menu within the VWorks software.

To open the VWorks knowledge base:

- Within the software, select **Help > Knowledge Base** or press F1.
- From the Microsoft Windows **All Apps** menu, select **Agilent Technologies > VWorks Knowledge Base**.
- *PDF files*. The PDF files of the user guides are installed with the VWorks software and are on the software CD that is supplied with the product. A PDF viewer is required to open a user guide in PDF format. You can download a free PDF viewer from the internet. For information about using PDF documents, see the user documentation for the PDF viewer.
- *Agilent website*. You can search the online Automation Solutions knowledge base or download the latest version of any PDF file from the following website: www.agilent.com/chem/askb

Reporting problems

Contacting Automation Solutions Technical Support

If you find a problem with the Bravo Platform, contact Agilent Automation Solutions Technical Support. For contact information, see Notices on the back of the title page.

Reporting hardware problems

When contacting Agilent Technologies, make sure you have the serial number of the device ready. You can find the serial number on the Bravo serial number label located on the back of the device.

Reporting software problems

When you contact Automation Solutions Technical Support, make sure you provide the following:

- Short description of the problem
- Relevant software version number (for example, automation control software, diagnostics software, and firmware)
- Error message text (or screen capture of the error message dialog box)
- Relevant files, such as log files

Reporting user guide problems

If you find a problem with this user guide or have suggestions for improvement, send your comments in an email to documentation.automation@agilent.com.



1 Safety guidelines

This chapter contains the following topics:

- “General safety information” on page 2
- “Safety and regulatory compliance” on page 3
- “Emergency stops” on page 5
- “Mechanical hazards” on page 6
- “Ergonomics” on page 9
- “Cut hazard” on page 10

General safety information

Before installing and using the Bravo Platform

Before installing and using the Bravo Platform, make sure you are aware of the potential hazards and understand how to avoid being exposed to them. You must be properly trained in the correct and safe installation and operation of the device. For the intended product use statement and safety label descriptions, see the *Automation Solutions Products General Safety Guide*.



WARNING Changing or modifying the Bravo Platform safety equipment may prevent the safe operation of the Bravo Platform, invalidate its safety compliance, and lead to personal injury or property damage. Any customer who does not use the supplied safety equipment or who modifies the supplied safety equipment assumes full responsibility for providing an appropriate level of safety for its operators and for providing the applicable safety compliance marking and documentation.

The following figure shows the location of the warning labels on the Bravo Platform.

Figure Bravo Platform warning label location

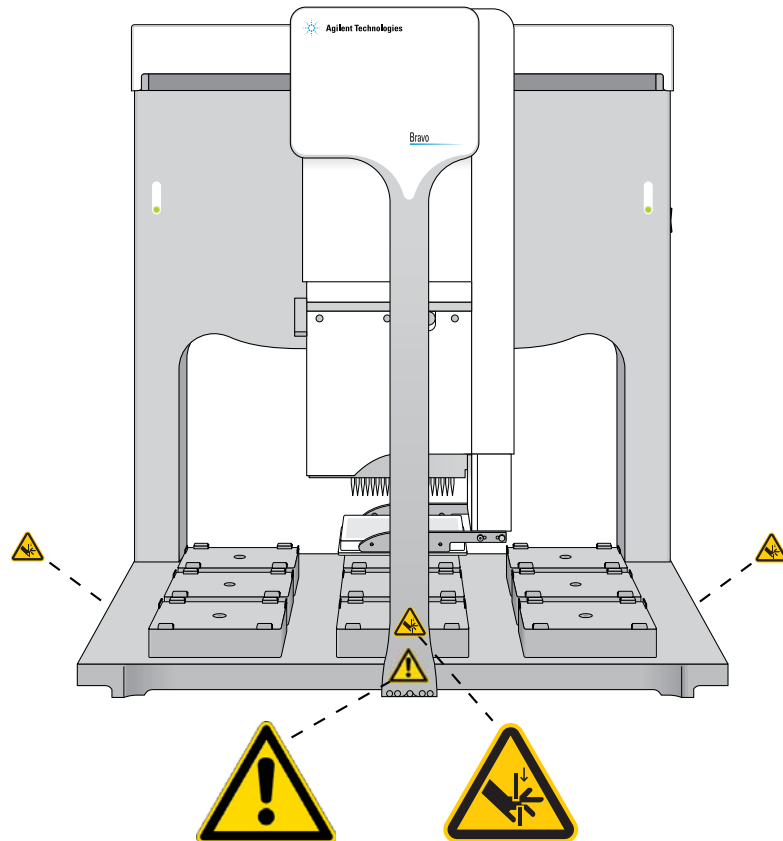

Safety and regulatory compliance

The Bravo Platform, when completely assembled with the liquid-handling head, the light curtain, and other components specified in the Declaration of Conformity, complies with the applicable EU Directives and bears the CE marking. The Bravo device alone, without the specified components, is considered a *partly completed machine*. In this case, the device has no CE marking and comes with a Declaration of Incorporation, because it is intended to be incorporated into a compliant system.

See the Declaration of Conformity or Declaration of Incorporation, as applicable, for details. The Bravo Platform is designed to comply with the regulations and standards listed in the following table.

Regulatory Compliance	Standard
EMC	
European Union	EMC Directive 2014/30/EU
	IEC 61326-1:2012/EN 61326-1:2013
Canada	ICES/NMB-001:2006
Australia/New Zealand	AS/NZS CISPR 11:2011
RoHS	
European Union	RoHS Directive 2011/65/EU
Safety	
European Union	Machinery Directive 2006/42/EC
	Low Voltage Directive 2014/35/EU
	IEC 61010-1:2010/EN61010-1:2010
	IEC 61010-2-081:2015/EN 61010-2-081:2015
Canada	CAN/CSA-C22.2 No. 61010-1-12
	CAN/CSA-C22.2 No. 61010-2-081-15
USA	ANSI/UL 61010-1-2012
	ANSI/UL 61010-2-081:2015

Electromagnetic compatibility

If the Bravo Platform causes interference with radio or television reception, which can be determined by turning the device off and on, try one or more of the following measures:

- Relocate the radio or television antenna.
- Move the device away from the radio or television.
- Plug the device into a different electrical outlet, so that the device and the radio or television are on separate electrical circuits.
- Make sure that all peripheral devices are also certified.

1 Safety guidelines

Safety and regulatory compliance

- Make sure that appropriate cables are used to connect the device to peripheral equipment.
- Consult your equipment dealer, Agilent Technologies, or an experienced technician for assistance.

Changes or modifications not expressly approved by Agilent Technologies could void the user's authority to operate the equipment.

South Korea EMC Declaration

The following EMC declaration applies to:

- 1 All models that were registered on or after 7 December 2016, but
- 2 Not to models included in a product family or series that was registered before 7 December 2016 (even if the model was added to the product family or series on or after 7 December 2016).

EMC declaration for South Korea

This equipment has been evaluated for its suitability for use in a commercial environment. When used in a domestic environment, there is a risk of radio interference.

EMC 선언

다음 EMC 선언은

- 1 2016년 12월 7일 자 또는 이후에 등록된 모든 모델은,
- 2 2016년 12월 7일 이전에 등록된 제품군 또는 시리즈를 포함한 모델은 2016년 12월 7일 자 또는 이후에 제품군 또는 시리즈에 추가되었을지라도 적용 되지 않습니다

사용자안내문

이 기기는 업무용 환경에서 사용할 목적으로 적합성평가를 받은 기기로서 가정용 환경에서 사용하는 경우 전파간섭의 우려가 있습니다.

※ 사용자 안내문은 " 업무용 방송통신기자재 " 에만 적용한다 .

Sound emission declaration

Sound pressure: $L_p < 70$ dB according to EN ISO 779:2010.

Schalldruckpegel: $L_p < 70$ dB nach EN ISO 779:2010.

Emergency stops

Procedure



WARNING If the Bravo Platform is integrated with other devices in a system, Agilent Technologies recommends that you install a main emergency stop button that will stop all devices simultaneously. In addition, all operators must be instructed in the emergency stop procedure.

CAUTION You might not be able to resume a protocol after an emergency stop. Do not use an emergency stop to pause a run. To pause and continue a run, use the appropriate commands in the VWorks software.

To stop in an emergency:

Press the red button on the emergency-stop pendant. The Bravo head stops immediately.

Figure Emergency-stop pendant

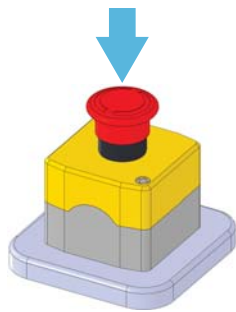

To recover from an emergency stop

- 1 Remove any labware that was dropped and clean up any spills.
- 2 Release the red button on the pendant by turning it clockwise.
- 3 In the VWorks software message box, select one of the options to abort, retry, or continue. This will re-enable the axes motors.

Mechanical hazards

Moving parts hazard

The Bravo Platform has moving parts that are accessible at the front, sides, and rear of the device, if not protected by shields and a light curtain.

The following figures and tables show the potential moving-parts hazards. Note that the moving parts hazard area includes a piercing hazard.

Figure Bravo Platform (top front view) showing moving-parts hazards

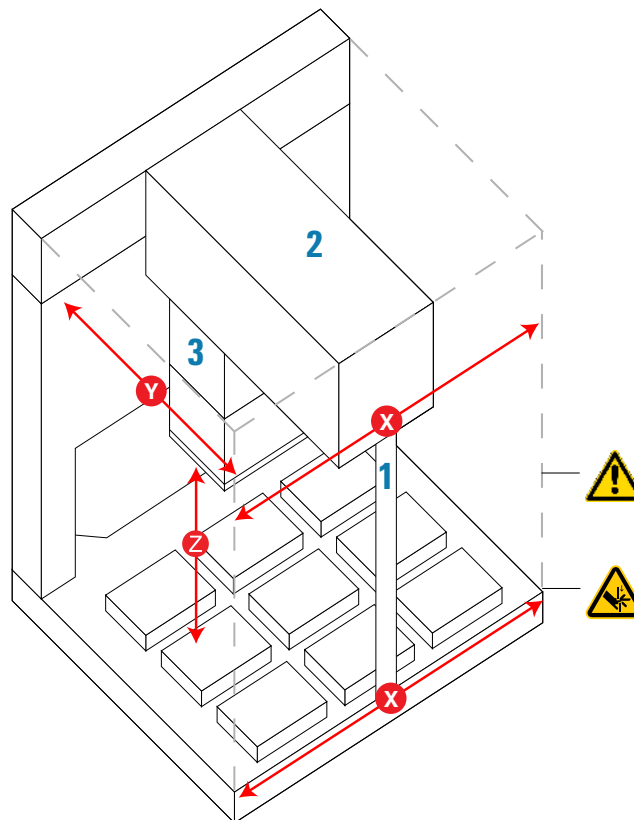

Item	Part	Axis of motion	Description
1	Tie bar	x -axis	The tie bar is attached to the arm and moves side to side across the front of the deck.
2	Arm	x -axis	The arm carries the head mount side to side across the deck.
3	Head mount	y -axis	The liquid-handling head attaches to the head mount, which moves back and forth on the arm between the back and front of the deck.
		z -axis	The head mount raises and lowers the liquid-handling head.

Figure Moving parts on Bravo gripper assembly

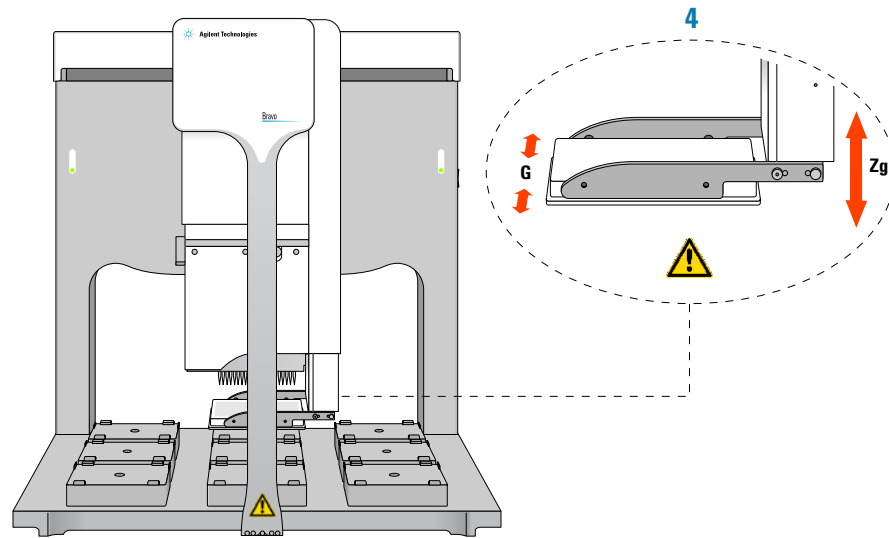

Item	Part	Axis of motion	Description
4	Gripper assembly	G-axis	The gripper fingers close and open to grip and release labware.
		Zg-axis	The gripper moves up to provide clearance when the head is moving across the deck, and down to extend beyond the liquid-handling head to pick and place labware.

Mitigating the risk to users



WARNING To reduce the risk of injury from moving parts, ensure that the Bravo safety interlock circuit is connected to a light curtain or an enclosure with an interlock switch.

The Bravo Platform has a safety interlock circuit that must be closed for the device to operate. Interrupting the safety interlock circuit will stop the motion of the robot head. Agilent Technologies highly recommends, and workplace safety laws in many countries require, that you connect the Bravo Platform safety interlock circuit to a Bravo light curtain or an enclosure with an interlock switch to mitigate the risk from moving parts.

If the Bravo Platform is operated outside an enclosure, a Bravo light curtain and safety shields are required to prevent operator access to moving-parts hazards. For instructions, see “[Bravo light curtains and shields](#)” on page 29.

It is the responsibility of every operator to follow the warnings and safety labels and to keep away from the Bravo Platform whenever the device is likely to move.



WARNING If you touch any of the moving parts or attempt to move labware while the Bravo Platform is in operation, the device could pinch, pierce, or bruise you. Keep your fingers, hair, clothing, and jewelry away from the device while it is in motion.



WARNING The Bravo head z-axis motor is particularly powerful. It might not stop immediately in a collision and a pipette tip could pierce your hand. Keep away from the Bravo Platform when the Bravo head is moving or about to move, especially in the z-axis direction.



WARNING When you initialize the Bravo Platform, the head and tie bar can move. To prevent injury, keep clear of the device while it is in motion.



WARNING Connecting the Bravo Platform to a company or general network can potentially cause injury. Remote computer operators might accidentally initiate an operation that causes the robot to move unexpectedly, possibly injuring nearby lab personnel. Avoid connecting the Bravo Platform to a company or general network. Ensure that anyone with access to the Bravo Platform is trained in the potential hazards and how to avoid them.

Ergonomics

About lifting the Bravo Platform



WARNING The Bravo device weighs approximately 52.1 kg (114.9 lb). Attempting to move the Bravo device without assistance could cause personal injury. Request assistance and use proper lifting techniques when moving the Bravo device.

Figure Correct lifting technique

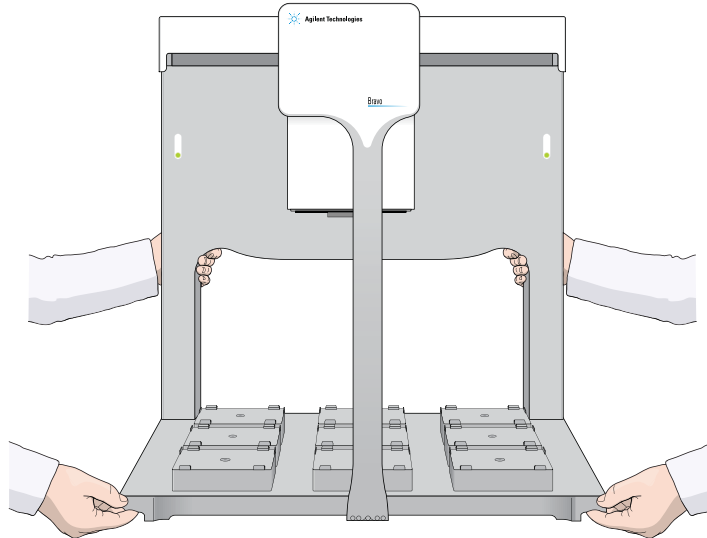

CAUTION Tugging on the tie bar or using it to lift the device can damage the device.

Figure Incorrect lifting or handling technique

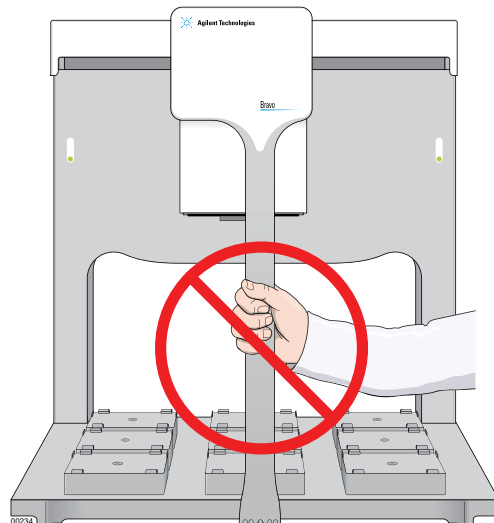

Cut hazard



WARNING The probes of the AssayMAP Bravo 96AM Head are sharp and can scratch you if they brush across your hand. A probe scratch can expose you to any contaminants remaining on the probes. Wear gloves and use extreme caution to avoid brushing against the probes.

Figure AssayMAP Bravo 96AM Head

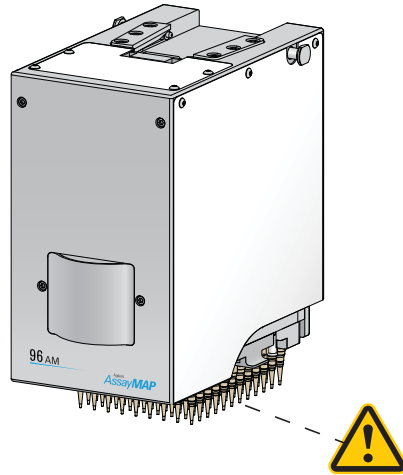

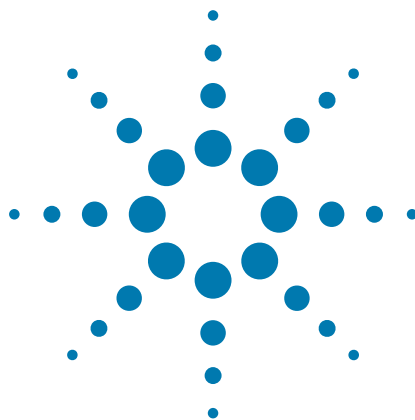

2 Installing the Bravo Platform

This chapter contains the following topics:

- “Installation workflow” on page 12
- “Laboratory setup requirements” on page 13
- “Connecting the Bravo Platform” on page 18
- “Installing the platepads” on page 17
- “Installing the liquid-handling head” on page 22
- “Bravo light curtains and shields” on page 29
- “Installing the rear shield” on page 45
- “Installing the dust cover” on page 48
- “Starting up and shutting down” on page 49

Installation workflow

Before you begin

The Bravo Platform can be installed as a single device controlled by a computer or integrated with other devices in a lab automation workstation. For either configuration, ensure that you connect the Bravo safety interlock circuit to a Bravo light curtain or an enclosure with an interlock switch to mitigate the risk to users from moving parts.

If the Bravo Platform will be operated outside of an enclosure, install the Bravo safety equipment, as described in the following workflow.



WARNING To reduce the risk of injury from moving parts, ensure that the Bravo safety interlock circuit is connected to a Bravo light curtain or an enclosure with an interlock switch.

Workflow

Step	For this task...	See...
1	Verify that the installation location meets the site requirements.	“Laboratory setup requirements” on page 13
2	Unpack the computer and connect the monitor, power, mouse, and keyboard.	Manufacturer’s instructions
3	Install the VWorks software.	Software release notes or <i>VWorks Automation Control Setup Guide</i>
4	Unpack the Bravo Platform.	<i>Bravo Platform Unpacking Guide</i>
	IMPORTANT If you are installing risers (step 5), do not remove the <i>y</i> -axis shipping stop from the head mount until after you have installed the risers.	
5	If required, install the risers to elevate the height of the deck. Ensure the <i>y</i> -axis shipping stop is removed from the Bravo head mount.	Agilent Automation Solutions Technical Support
6	Install the platepads on the Bravo deck.	“Installing the platepads” on page 17
7	If applicable, install the deck accessories.	<i>Bravo Platform User Guide</i>
8	Connect the Bravo Platform.	“Connecting the Bravo Platform” on page 18
9	Install the liquid-handling head.	“Installing the liquid-handling head” on page 22
10	Install the safety equipment.	“Bravo light curtains and shields” on page 29

Step	For this task...	See...
11	<i>Optional.</i> Install the dust cover.	“Installing the dust cover” on page 48
12	Set up the Bravo device profile and set the teachpoints.	<i>Bravo Platform User Guide</i>

Laboratory setup requirements

About this topic

This topic describes the lab requirements for the Bravo Platform. Read this topic before you unpack and install the Bravo Platform.

Space and bench requirements

Device dimensions and weight

The Bravo Platform has the following physical specifications:

Table Standard Bravo Platform

Dimension	Bravo Platform	Bravo Platform with Standard Light Curtain	Bravo Platform with Wraparound Light Curtain
Height	69.7 cm (27.4 in)	69.7 cm (27.4 in)	69.7 cm (27.4 in)
with risers	84.3 cm (33.2 in)	84.3 cm (33.2 in)	84.3 cm (33.2 in)
Width	64.8 cm (25.5 in)	66.5 cm (26.2in)	78.0 cm (30.7 in)
Depth	43.8 cm (17.2 in)	52.5 cm (20.7in)	47.4 cm (18.7in)
Weight	52.1 kg (114.9 lbs)	60.7 kg (133.5 lbs)	61.9 kg (136 lbs)

2 Installing the Bravo Platform

Laboratory setup requirements

Figure Dimensions of a standard Bravo Platform (left) and the SRT Bravo Platform (right)

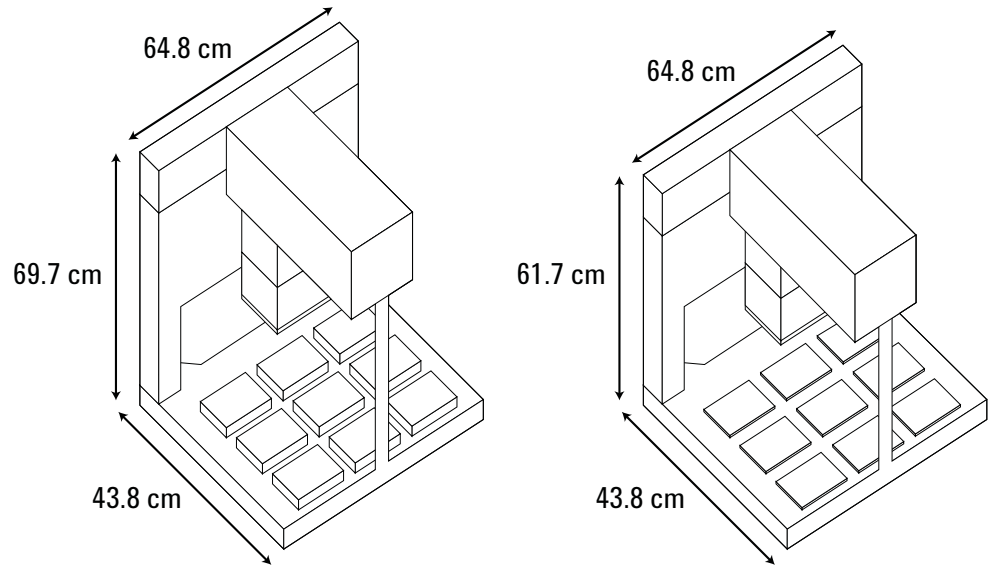

Figure Example of Standard Bravo Platform on risers

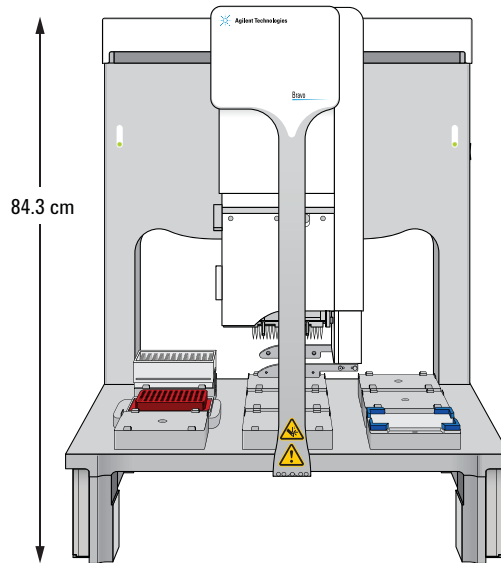

Table SRT Bravo Platform

Dimension	SRT Bravo Platform	SRT Bravo Platform with Standard Light Curtain	SRT Bravo Platform with Wraparound Light Curtain
Height	61.7 cm (24.3 in)	61.7 cm (24.3 in)	61.7 cm (24.3 in)
with risers	76.3 cm (30 in)	76.3 cm (30 in)	76.3 cm (30 in)
Width	64.8 cm (25.5 in)	66.5 cm (26.2in)	78.0 cm (30.7 in)
Depth	43.8 cm (17.2 in)	52.5 cm (20.7in)	47.4 cm (18.7in)
Weight	51.5 kg (113.5 lb)	60.1 kg (132.5 lb)	61.3 kg (135 lb)

Laboratory table or bench requirements

The laboratory table must:

- Have enough space to accommodate the Bravo Platform, computer, monitor, pendant, and accessories.
- Support the weight of the Bravo Platform and other components without excessive shaking or movement.
- Be fixed in place, for example, casters that lock.
- Have proximity to a power outlet, and allow rear access to enable quickly disconnecting the power to the Bravo Platform if the need arises.

The supplied power cord is 1.83 m (6 ft) long.

- Allow access to the rear of the Bravo Platform for maintenance.

Note: If the Bravo Platform is outside an enclosure, the Bravo rear shield prevents rear access to the device's moving parts while still allowing easy access to the rear power connections.

The table must be level in the direction of the width and the depth of the platform. Using a traditional bubble level, the table should be leveled such that the bubble is centered between the two limit lines of the level.

The table surface must have a thickness relative to the material that will prevent warping when the Bravo Platform and computer are set upon the table.

The table surface must be attached to the table frame.

The table frame must have:

- A leveling mechanism in the feet or casters.
- Dimensions that enable support of the table surface without overhang.

Electrical requirements

The Bravo Platform has the following electrical requirements:

Requirement	Value
Voltage	100–240 V~
Frequency	50/60 Hz
Power, maximum	300 VA
Fuse	250 V, 6.3 A, 5 mm x 20 mm, time delay

Environmental operating requirements

The Bravo Platform is for indoor use only. The following table lists the operating specifications.

If you have integrated devices, your system might require additional cooling depending on the number and types of integrated devices.

Operating	Specification
Pollution degree	2
Installation category	II
Temperature	4–40 °C
Humidity	10–90% RH, non-condensing
Altitude	1–2000 m

Computer requirements

Ensure that the computer contains the following software versions at a minimum.

- Microsoft Windows 10 64-bit operating system
- VWorks Automation Control software v13.1

See the VWorks software release notes for installation instructions and additional computer requirements. You can also go to the VWorks knowledge base at www.agilent.com/chem/askb.

Installing the platepads

The Bravo deck has nine labware locations. A platepad or accessory is installed at each of the nine locations to hold the labware in position. Several types of platepads are available for the Bravo Platform: standard, tall, and short. Each platepad has a crosshairs in one corner, which is used to set the pipettor teachpoint for the deck location. The following figure shows a standard platepad.

Figure Standard platepad with crosshairs

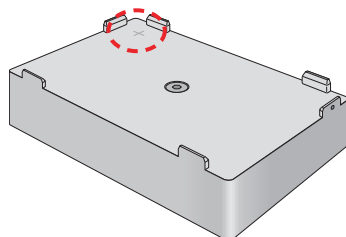

Before you start

Make sure you have the following:

- Platepad
- Flathead cap screw, M6 x 40 mm

IMPORTANT Debris on the bottom surface of the platepad can prevent it from sitting level on the deck. Ensure that the platepad is clean before you install it.

Procedure

To install a platepad:

- 1 With the crosshairs toward the back side of the device, align the pins in the bottom of the platepad with the holes on the deck.

Figure Platepad crosshairs orientation on the Bravo deck (top view)

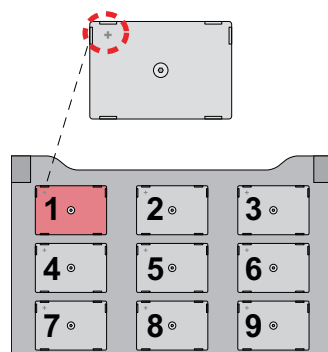

Make sure the pins are inserted correctly and the accessory sits level on the deck.

- 2 Secure the platepad to the deck using the screw provided.

- 3 Ensure that the setscrews in the platepad tabs are recessed and not protruding into the plate nest. Use a 1.5-mm hex wrench to back out any protruding setscrews.

IMPORTANT A protruding setscrew will prevent proper seating of the labware in the platepad.

Figure Setscrew in platepad tab

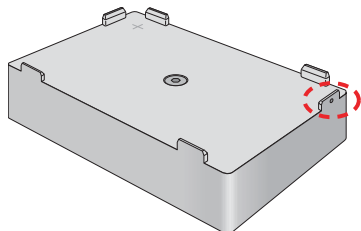

Connecting the Bravo Platform

About this topic

This topic provides basic connection instructions for the Bravo Platform.

Figure Example of Bravo Platform basic connections

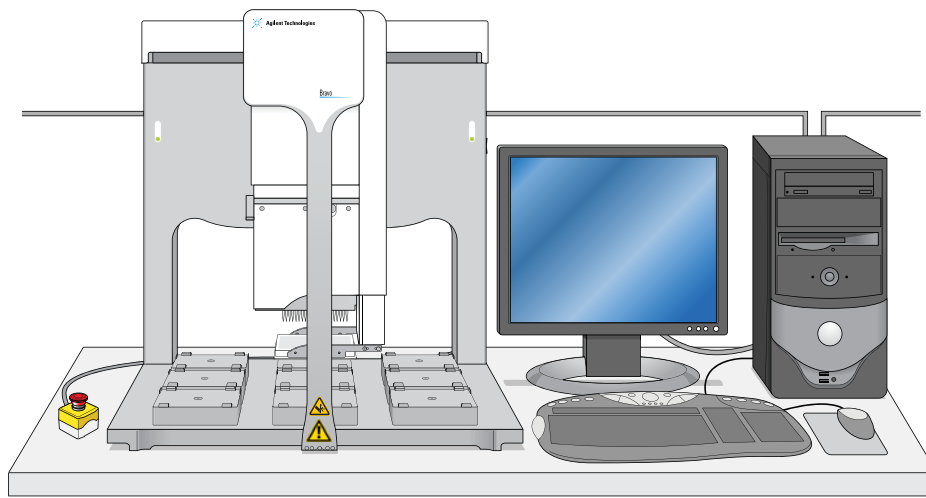

Before you start

- Make sure the laboratory setup requirements have been met.
- Determine the placement of the Bravo Platform and computer. If the Bravo Platform is integrated in a workstation, determine the Bravo deck location for the external robot to hand off labware.

- Follow the instructions included with the computer for setting up the computer. Ensure that the computer and Bravo Platform are turned off.
- Make sure you have the supplied Ethernet cables.

Bravo rear connection panel

The following figure and table describe the connection panel at the rear of the Bravo Platform.

Figure Connection panel on back of Bravo Platform

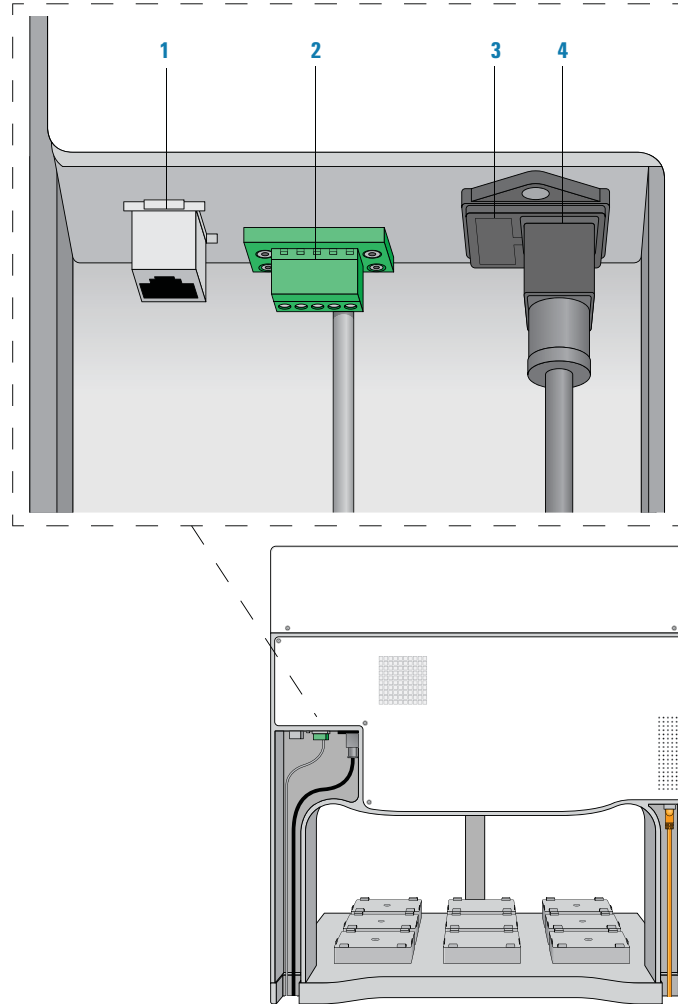

Item	Feature	Description
1	Ethernet port	Connects the Ethernet card in the controlling computer to the Bravo Platform.

Item	Feature	Description
2	Pendant port	Connects the emergency-stop pendant and a Bravo light curtain to the Bravo safety interlock circuit. The connection is made through the junction box for a standalone Bravo Platform. For an integrated Bravo Platform, the connection is made through a main emergency-stop control, such as the Agilent Automation Control Unit or Robot Disable Hub. IMPORTANT The safety interlock circuit must be closed for the Bravo Platform to operate.
3	Fuse holder	Houses the AC inlet fuse and a spare fuse for the Bravo Platform.
4	AC power entry	Connects the Bravo power cord to an AC outlet with a grounded circuit.

Pump I/O port

The following figure shows the Pump I/O port on the back of the Bravo Platform. The table below describes the Pump I/O port in detail.

Figure Pump I/O port (Bravo Platform back view)

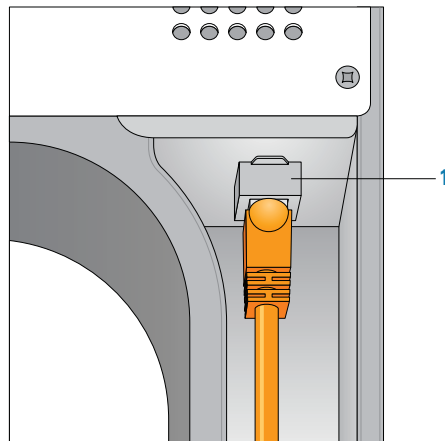

Item	Feature	Description
1	Pump I/O port	An RJ-45 I/O port that connects the Pump Module to the Bravo Platform. The connection is made with a straight-through shielded Cat-5 or Cat-6 (Ethernet) cable. IMPORTANT This is not an Ethernet port.

Connecting the power and pendant



WARNING To reduce the risk of injury from moving parts, ensure that the Bravo safety interlock circuit is connected to a light curtain or an enclosure with an interlock switch.

You will reconnect the power cord and pendant during the Bravo light curtain installation procedure. However, you should connect the power cord and pendant at this step to ensure that the Bravo Platform functions before installing a Bravo light curtain.

To connect the power cord and pendant without a light curtain:

- 1 Connect one end of the power cord to the AC power entry on the back of the Bravo Platform. Connect the other end of the cord into an AC outlet with a grounded circuit.
- 2 Connect the pendant into the pendant port on the back of the Bravo Platform.

Connecting the Bravo Platform to the controlling computer

You use Ethernet to connect a Bravo Platform to the computer in one of the following ways:

- Directly
- Through an Ethernet switch

If you are setting up a standalone Bravo Platform, you can use either method. If you are setting up a local area network (LAN) that has other devices on it, use an Ethernet switch.

The Agilent configured computer has two Ethernet ports. You use one port to connect to the Bravo Platform. The second Ethernet port may be used to connect to your LAN. Verify the computer LAN connection to the Bravo Platform before connecting any other networks.



WARNING Connecting the Bravo Platform to a company or general network can potentially cause injury. Remote computer operators might accidentally initiate an operation that causes the robot to move unexpectedly, possibly injuring nearby lab personnel. Avoid connecting the Bravo Platform to a company or general network. Ensure that anyone with access to the Bravo Platform is trained in the potential hazards and how to avoid them.

Connecting directly to the computer

To connect directly to the computer using Ethernet:

- 1 Connect one end of the Ethernet cable to the Ethernet port on the Bravo Platform.
- 2 Connect the other end of the cable to the Ethernet port on the computer.

Connecting through an Ethernet switch

To connect through an Ethernet switch:

- 1 Connect the switch to the computer as follows:
 - a Connect the power cord to the switch.
 - b Connect one end of the Ethernet cable (black) into any Ethernet port on the switch, and connect the other end of the cable to an Ethernet port on the computer.

- 2** Connect the Bravo Platform to the switch as follows:
 - a** Connect one end of a second Ethernet cable to a port on the Ethernet switch.
 - b** Connect the other end of the cable to the Ethernet port on the Bravo Platform.

You can connect as many devices to the network as there are Ethernet ports available.

About configuring the computer's network card (Ethernet only)

For the Agilent-configured computer, no change is required to the network card IP address.

If you are using a computer other than an Agilent-configured computer, make sure the value of the network card IP address and subnet mask are as follows:

- IP address: 192.168.0.1
- Subnet mask: 255.255.255.0

If your computer will be connected to your LAN, make sure the computer has a second network card. The second network card can have a dynamic IP address.

Note: The Bravo device has a default IP address of 192.168.0.8. If you need to change the default IP address, contact Agilent Automation Solutions Technical Support.

Installing the liquid-handling head

About this topic

This topic describes how to mount the liquid-handling head when you first set up the Bravo Platform. The procedure is for the current Bravo liquid-handling heads, including the disposable-tip heads (Series III), pin tools, and the AssayMAP Bravo 96AM Head.

Note: If you want to install a Series II disposable-tip head on a Bravo Platform that has a gripper, you must ensure that the gripper is lowered from the docked position before attempting to install the head.

Before you start

CAUTION Always turn off the Bravo Platform before installing or uninstalling a liquid-handling head. Failure to do so can damage the head electronics.

Before installing a liquid-handling head, familiarize yourself with the features shown in the following figures:

- Bravo head mount contains a head lock (1) and a dovetail connector (2), as the following figure shows.
- Each liquid-handling head contains two head-retainer pins (3) and a dovetail interface (4) that attaches to the dovetail connector on the Bravo head mount.

The dovetail interface connects the liquid-handling head electronics to the Bravo Platform. The two head-retainer pins and the head lock secure the liquid-handling head to the Bravo Platform.

Figure Bravo head mount with (1) head lock and (2) dovetail connector (bottom view)

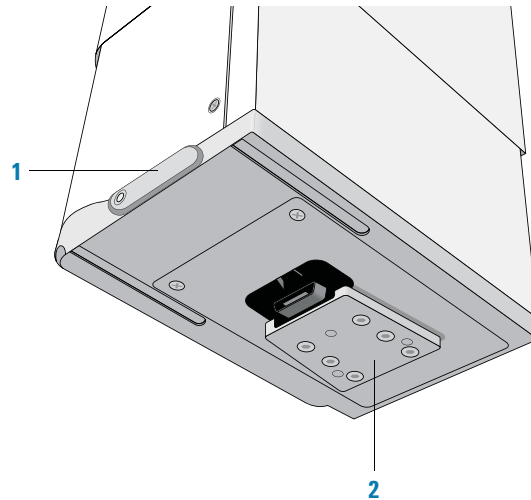
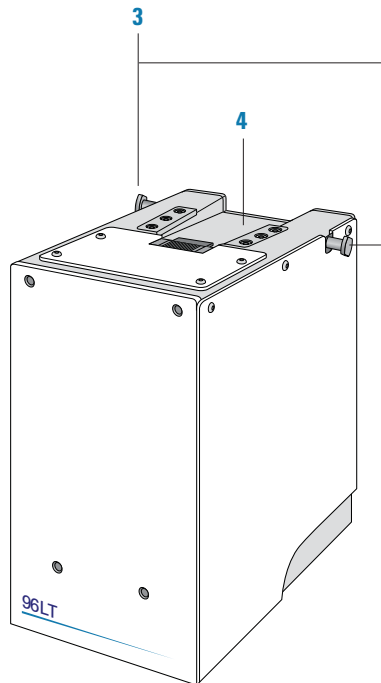

Figure Disposable-tip head with (3) retainer pins and (4) dovetail interface



Procedure

To install a Bravo liquid-handling head:

- 1** Make sure that the Bravo head mount is in its home position, which is centered above deck location 5. If the Bravo Platform is turned off, you can use your hands to move the head mount gently into position.

2 Installing the Bravo Platform

Installing the liquid-handling head

Note: If the Bravo Platform is already initialized, you can use Bravo Diagnostics to move the head mount to the home position.

Figure Bravo deck locations (top view)

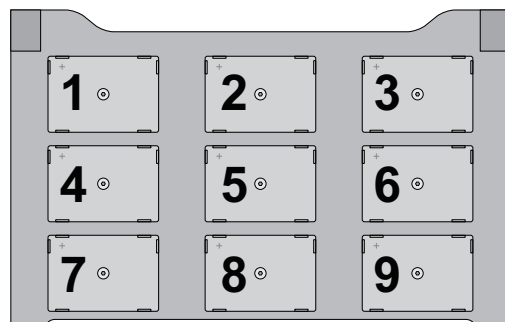

Front

- 2 Ensure that the Bravo Platform is turned off. Check that the power switch located on the right side is set to **off** (o) and the status lights on the device front are not lit.

Figure Bravo Platform status lights (front) and power switch (right side)

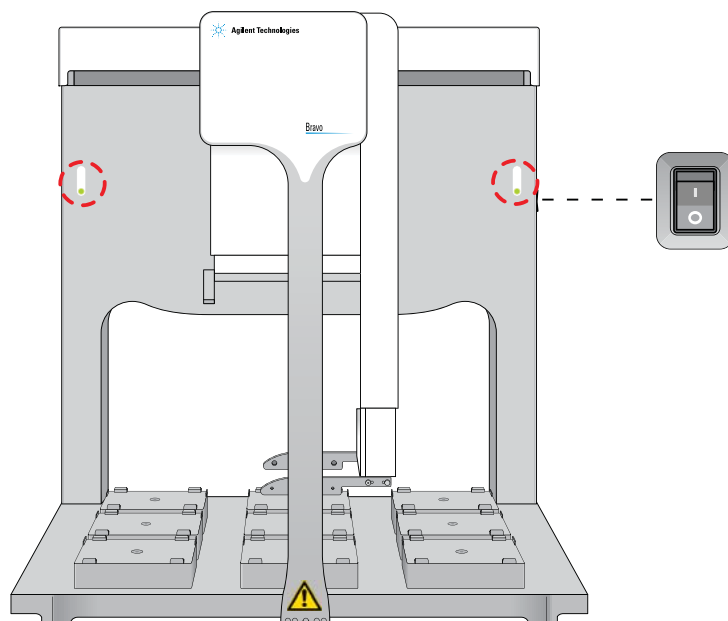

- 3 Carefully remove the liquid-handling head and protective stand from the packaging. While the head remains seated in the stand, pull out and twist the two head-retainer pins one-quarter turn so that they remain retracted. See the following figure.

CAUTION Do not rest the bottom of a liquid-handling head on any surface. Doing so can damage the barrels, pins, or probes.

CAUTION To prevent potential contamination, do not touch the liquid-handling head barrels, tips, or probes with your hands.

4 Remove the head from the stand as follows:

- *Disposable-tip heads.* Rest the bottom of the stand on a clean, dry surface. Slide the head out of the stand as the following figure shows, so that the barrels are facing down.

Figure Disposable-tip head: (1) retainer pins and (2) stand

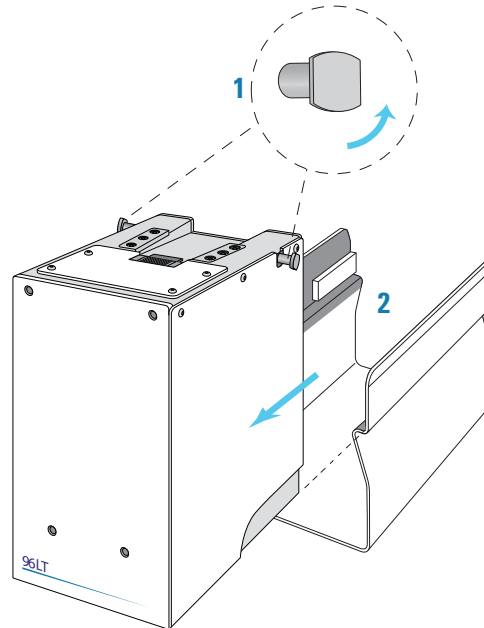

- *Bravo 96AM Head.* Ensure that the top of the head is resting on a clean, stable surface so that the probes are facing up.



WARNING The probes of the AssayMAP Bravo 96AM Head are sharp and can scratch you if they brush across your hand. A probe scratch can expose you to any contaminants remaining on the probes. Wear gloves and use extreme caution to avoid brushing against the probes.

Using both hands, carefully lift the stand off of the head while guiding the stand's side cutouts (1) off the head side tabs (2). Use care to avoid touching the probes.

2 Installing the Bravo Platform

Installing the liquid-handling head

Figure Bravo 96AM Head: (1) stand cutouts and (2) head tabs

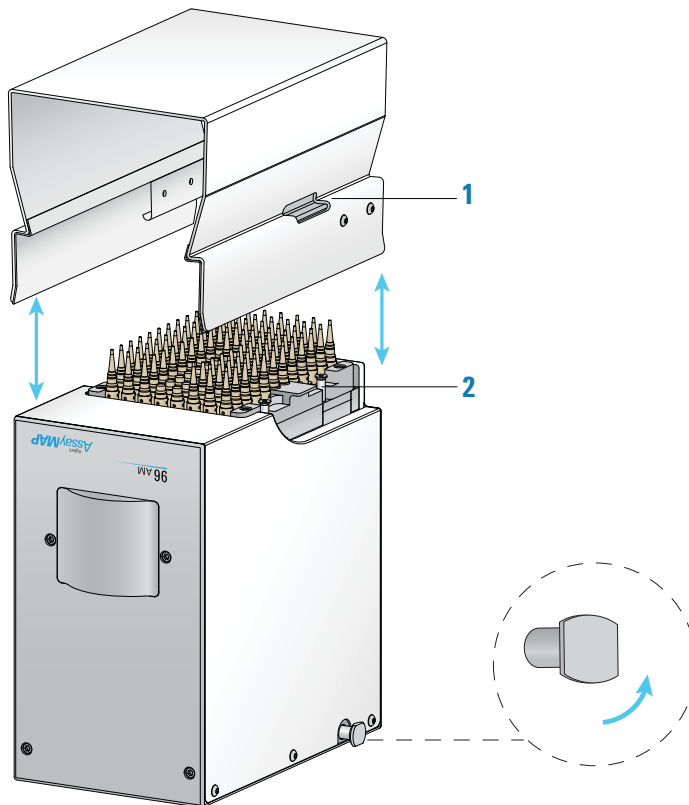

- 5** With your left hand, firmly grip the left side of the head. Place your right hand under the flat area just to the left of the array to support the weight of the head.
- 6** While supporting the head with your hands, slide the head onto the Bravo head mount. Press the head firmly into place to ensure the head is plugged into the connector receptacle on the head mount. You should hear the click when the retaining pins snap into place.

Figure Installing the Bravo 96AM Head in the Bravo head mount

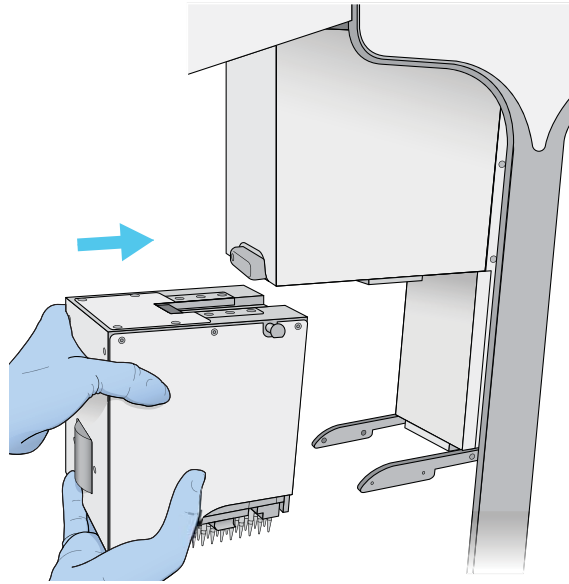

Note: If you do not hear the pins snap into place, check that the straight edges of the retainer pins are in the vertical position, as the following figure shows. Attempt to rotate the pins to ensure that they are in the locked position. The pins should not rotate freely.

Figure Installed Bravo 96AM Head: (1) retainer pin and (2) head lock

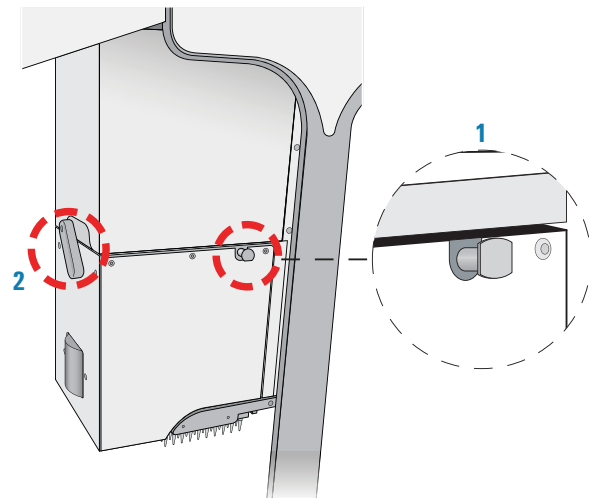

- 7** To lock the head, rotate the head lock clockwise until it reaches its hard stop. This ensures that the head is fully seated and does not shift position during operation.

2 Installing the Bravo Platform

Installing the liquid-handling head

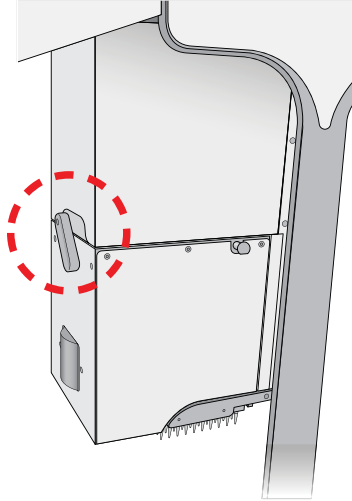

CAUTION Dropping the head or bumping the barrels or probes will damage the head. If the Bravo head is not properly secured in place, it could drop unexpectedly. Ensure that the head is securely locked into the head mount.

Bravo light curtains and shields

About this topic

This topic provides an overview of the Bravo light curtains and shields. The light curtain and shields protect operators from moving-parts hazards while the Bravo Platform is in operation. If the Bravo Platform is integrated within an enclosure that connects to the Bravo safety interlock circuit and you determine that the enclosure provides adequate protection to the operator, the enclosure can replace the Bravo light curtain and shields.



WARNING Changing or modifying the Bravo safety equipment may prevent the safe operation of the Bravo Platform, invalidate its safety compliance, and lead to personal injury or property damage. Any customer who does not use the supplied safety equipment or who modifies the supplied safety equipment assumes full responsibility for providing an appropriate level of safety for its operators and for providing the applicable safety compliance marking and documentation.

This topic includes:

- [“Types of Bravo light curtains” on page 29](#)
- [“Standard Light Curtain and shield components” on page 30](#)
- [“Wraparound Light Curtain and shield components” on page 33](#)
- [“Cleaning the light curtains and shields” on page 35](#)

Types of Bravo light curtains

The following light curtains are for use on a Bravo Platform only and not for use on other instruments:

- *Standard Light Curtain.* Enables operator access to the front of the Bravo deck while protecting operators from moving-parts hazards. A Bravo Platform with the Standard Light Curtain can be integrated with other devices that access the Bravo deck from the sides, such as the BenchCel Microplate Handler.

The Standard Light Curtain is available for a standalone Bravo Platform or a Bravo Platform that has devices integrated externally at either side of the deck.

- *Wraparound Light Curtain.* Enables operator access to the front and sides of the Bravo deck while protecting operators from moving-parts hazards. Maintaining the openings at the sides and the front enables more airflow to the Bravo deck, which may be a requirement for installation inside a laminar flow hood.

The Wraparound Light Curtain is available only for a standalone Bravo Platform or a Bravo Platform that has no devices integrated externally from the Bravo deck. In addition, any deck accessory cabling or tubing must be routed through the Bravo rear opening.

Standard Light Curtain and shield components

The Standard Light Curtain contains two lightposts mounted at the front of the Bravo Platform that project light beams across the front of the device. If an object disrupts the light beams, the safety interlock circuit is tripped and the motion of the Bravo head stops.

The following figure and table provide details on the Standard Light Curtain and the front and side shields.

For installation instructions, see “Installing the Standard Light Curtain and shields” on page 36.

Figure Bravo Platform with Standard Light Curtain and shields (front view)

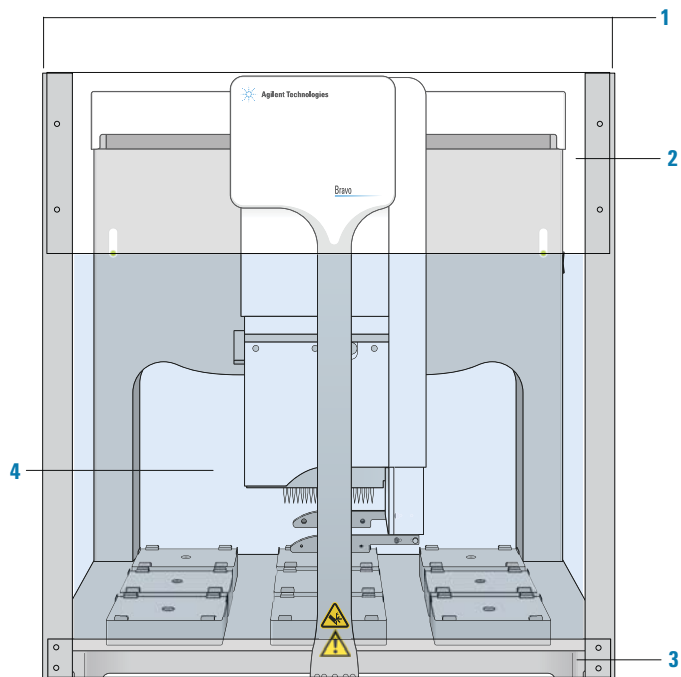

Item	Name	Description
1	Lightposts	The two lightposts, which mount on each end of the Bravo base, contain the transmitter and receiver that project the light beams, detect disruptions in the beam, and transmit signals to the safety interlock circuit.
2	Upper front shield	A clear plastic shield, which attaches to the two lightposts, prevents access at the front between the top of the light shield and the Bravo top.
3	Lower front shield	A clear plastic shield, which attaches to the two lightposts, prevents access at the front between the bottom of the light shield and top of the Bravo deck.
4	Light shield (invisible)	After the light beams are aligned, the Standard Light Curtain generates an invisible light shield that spans the area between the two lightposts across the front of the Bravo Platform.

Item	Name	Description
5	Side shields (See the following figure for an example.)	Clear plastic shields prevent access through the sides openings of the Bravo Platform. Each side shield attaches to a lightpost and the Bravo backplate. Each shield has deck-access windows with removable covers for routing cabling and tubing off the deck, as the following figure shows.

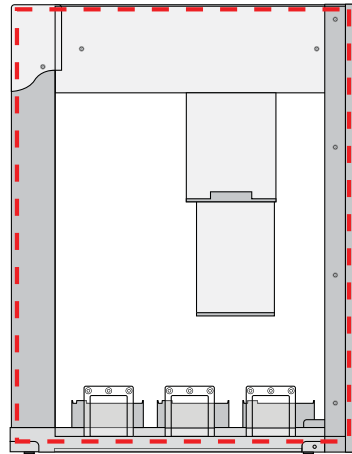

A side shield might not be required if the Bravo Platform is integrated with another device on a given side.

6	Rear shield (See the following figure.)	A clear plastic shield that prevents access through the rear opening of the Bravo Platform. The shield has three access windows for routing cabling and tubing off the deck, as the following figure shows.
---	--	---

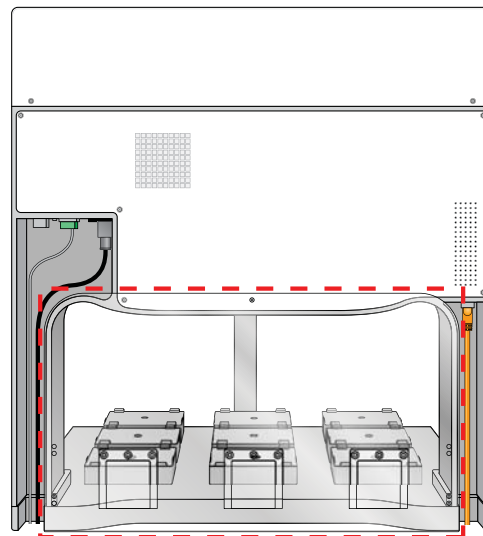

A rear shield might not be required if the Bravo rear opening is not accessible to operators.

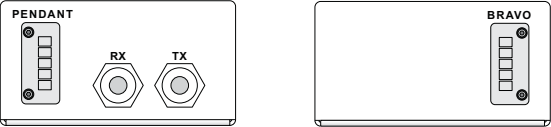
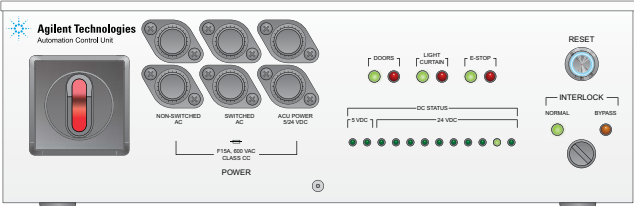
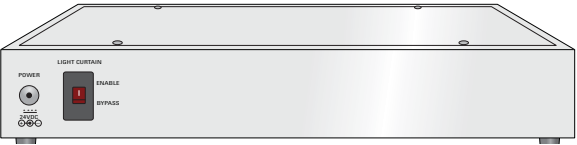
Item	Name	Description
7	Connection box (Junction box, Robot Disable Hub, or Automation Control Unit) (not shown)	<p>Pendant and Standard Light Curtain connections:</p> <ul style="list-style-type: none"> • <i>Standalone Bravo Platform.</i> Use the junction box when connecting only the Bravo Platform, emergency-stop pendant, and a Bravo curtain. <p>Figure Junction box (front view and rear view)</p>  <ul style="list-style-type: none"> • <i>Integrated Bravo Platform.</i> Use one of the following when integrating the safety interlock circuits of multiple devices: <ul style="list-style-type: none"> – <i>Automation Control Unit (ACU).</i> Provides AC power and power distribution, emergency-stop function, and safety interlock features for multiple devices, pendants, and a light curtain. Also provides detection sensor features to turn on or off status lights, open or close doors, and change the state of other items. For details, see the Automation Control Unit User Guide. <p>Figure ACU (front view)</p>  <ul style="list-style-type: none"> – <i>Robot Disable Hub.</i> Connects the interlock circuits of up to six devices, six pendants, and a light curtain. This hub is used when integrating the Bravo and BenchCel devices. For details, see the BenchCel Microplate Handler User Guide. <p>Figure Robot Disable Hub (front view)</p> 
8	Cable, extension (not shown)	The extension cable connects the Bravo pendant port to the junction box, Automation Control Unit, or Robot Disable Hub.

Wraparound Light Curtain and shield components

The Wraparound Light Curtain contains two lightposts that project light beams and two mirrorposts that reflect the projected light around the side and front openings of the Bravo Platform. If an object disrupts the light beams, the safety interlock circuit is tripped and the motion of the Bravo head stops. Front, side, and rear shields cover the remaining Bravo openings to protect operators from moving-parts hazards.

The following figure and table provide details on the Bravo Wraparound Light Curtain and shields.

IMPORTANT Only Agilent field service personnel may install the Bravo Wraparound Light Curtain.

Figure Bravo Platform with Wraparound Light Curtain and shields

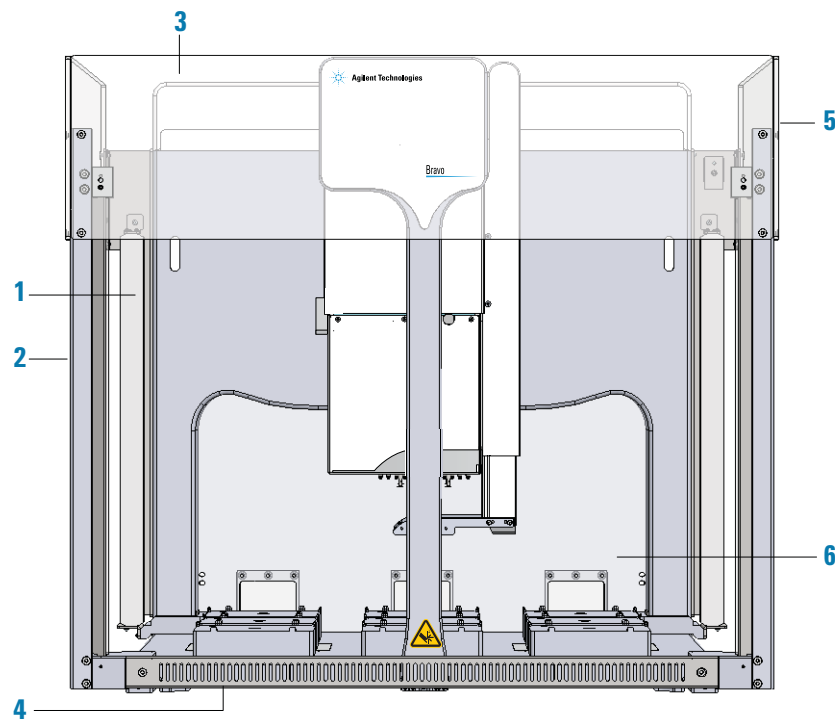

2 Installing the Bravo Platform

Bravo light curtains and shields

Item	Name	Description
1	Lightposts	<p>The two lightposts that mount on each end of the Bravo rear:</p> <ul style="list-style-type: none"> • Transmitter lightpost (left rear) projects the light beams across the Bravo left side opening to the left mirrorpost, which reflects the light beams across the front opening. • Receiver lightpost (right rear) detects the light beams reflected across the Bravo right side opening. <p>The lightposts are connected to the safety interlock circuit through the junction box. The lightposts detect any disruptions in the light beams. A column of LEDs on the lower front of each lightpost indicate the light curtain status.</p> <ul style="list-style-type: none"> • LED lights turn green when the light beams are aligned and no disruptions are detected. • LED lights turn red if the receiver does not detect the light beams. Improperly aligned mirrorposts or disruptions in the light beams cause the LED lights to turn red.
2	Mirrorposts	<p>The two mirrorposts that mount on the front left and front right corners of the Bravo base.</p> <ul style="list-style-type: none"> • The left front mirrorpost receives the light beams projected across the left side opening from the transmitter lightpost, and then reflects the light beams across the Bravo front opening. • The right front mirrorpost reflects the light beams across the right side opening to the receiver lightpost.
3	Upper front shield	A clear plastic shield that attaches to the two front mirrorposts to prevent access at the front between the top of the light shield and the Bravo top.
4	Bottom front metal guard	A ventilated metal shield that attaches to the two front mirrorposts to prevent access at the front between the bottom of the light shield and top of the Bravo deck.
5	Side shields	Clear plastic shields prevent access through the upper left and right side openings above the light shield.
6	Rear shield	<p>A clear plastic shield that prevents access through the rear opening of the Bravo platform. The shield has three access windows for routing cabling and tubing off the deck.</p> <p>A rear shield might not be required if the Bravo rear opening is not accessible to operators.</p>
7	Light shield (invisible)	When the light beams are aligned, the light curtain generates an invisible light shield that spans across the Bravo side and front openings.
8	Junction box (Shown in the following figure.)	The box that provides the connections for the Bravo emergency-stop pendant and the transmitter and receiver lightposts. The following figure shows the front view and rear view.

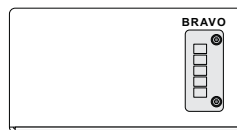
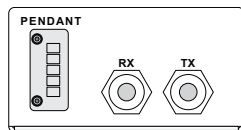

Item	Name	Description
9	Cable, extension (not shown)	The extension cable connects the Bravo pendant port to the junction box.

Note: For installation instructions, Agilent field-service personnel should refer to the [Bravo Wraparound Light Curtain Installation Guide](#).

Cleaning the light curtains and shields

CAUTION Fingerprints or dirt on the light curtain glass and mirrors can interfere with the operation. Avoid touching the glass and mirror panels with your fingers.

To clean the shields and the light curtain glass and mirror surfaces:

Use a soft, lint-free cloth and a mild detergent diluted with water, or use isopropyl alcohol.

Installing the Standard Light Curtain and shields

Before you start

The Standard Light Curtain and shields may be installed only on a Bravo Platform by Agilent field service personnel.

Safety warnings and caution



WARNING To prevent potential injury, shut down the Bravo Platform and unplug the power cord before installing the Light Curtain.



WARNING Do not replace the pendant with the Standard Light Curtain. The Standard Light Curtain is an additional safety feature to be used with the pendant.



WARNING The light beams of the Standard Light Curtain extend across the front of the Bravo Platform only. Access to moving parts from the sides or back of the device may be possible and cannot be detected by the Standard Light Curtain. If access from the sides or rear is possible, install the side and rear shields, as applicable.

CAUTION Handle the lightposts with care to prevent any damage to the glass panels. Avoid touching the glass panels with your fingers. Fingerprints or dirt on the glass can interfere with the Standard Light Curtain operation.

Required components and tools

Make sure that you have the following:

- Standard Light Curtain components (lightposts and extension cable)
- Shields
- Junction box (provided with the Standard Light Curtain) for a standalone Bravo Platform
Automation Control Unit or Robot Disable Hub for integrated Bravo Platform
- 2.5-mm and 3-mm hex wrenches
- Cross-tip screwdriver
- T10 and T20 Torx drivers
- Gloves to protect the lightpost glass from fingerprints and smudges

Workflow overview

Make sure that you perform the procedures in the following order:

Step	Procedure	See...
1	Install the lightposts on the Bravo Platform.	“Installing the lightposts” on page 37
2	Connect the Standard Light Curtain to the Bravo Platform.	“Connecting the Standard Light Curtain” on page 38
3	Align the light beams.	“Aligning the light beams” on page 39

Step	Procedure	See...
4	Install the front and side shields.	<ul style="list-style-type: none">• “Installing the front shields” on page 42• “Installing the side shields” on page 43
5	Install the rear shield	“Installing the rear shield” on page 45

Installing the lightposts

To install the lightposts:

- 1 Position the foot of the left lightpost onto the Bravo front left base handle. To ensure a snug fit, press the lightpost foot firmly from the front and the side.

Note: The glass panel of the lightpost should face toward the Bravo center front.

IMPORTANT Ensure that the lightpost foot fits completely onto the Bravo base handle without any gaps in space. Otherwise, you will not be able to align the light beams correctly.

Figure Positioning a lightpost (side view and front view)

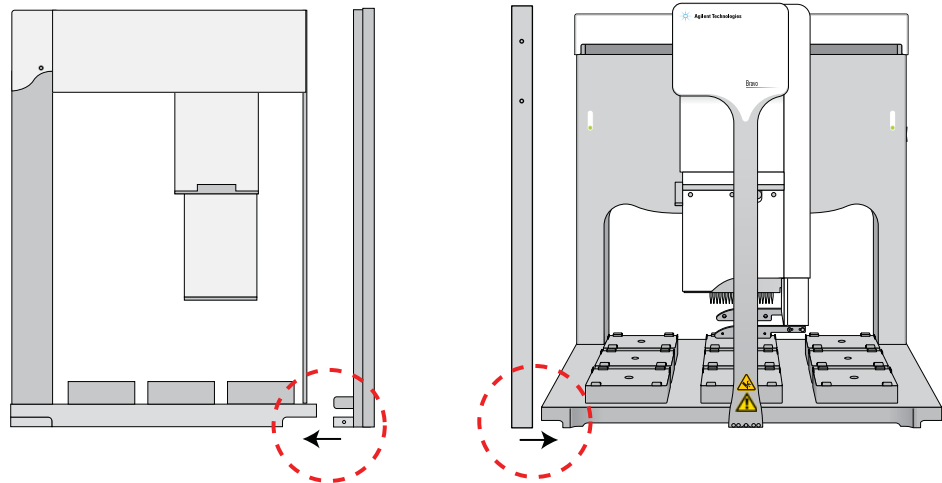

- 2 On the outer side of the lightpost foot, install the setscrew to lock the lightpost in position, as the following figure shows (1).

2 Installing the Bravo Platform

Installing the Standard Light Curtain and shields

Figure Lightpost setscrew (Bravo Platform side view)

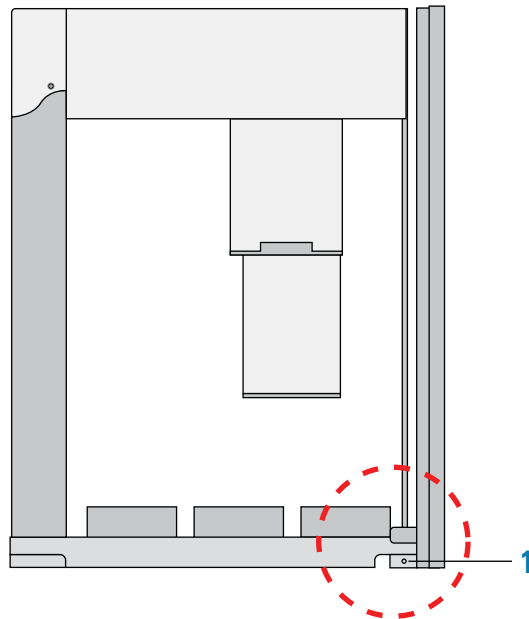

- 3 Repeat steps 1 and 2 to mount the front right lightpost.

Connecting the Standard Light Curtain

Use the following procedure to connect the Standard Light Curtain to a standalone Bravo Platform using the junction box.

If the Bravo Platform is integrated with an Automation Control Unit, see the [Automation Control Unit User Guide](#) for connection instructions.

If the Bravo Platform is integrated with a Robot Disable Hub, see the [BenchCel Microplate Handler User Guide](#) for connection instructions.

The ports for the pendant cable and the two lightpost cables are on the front of the junction box. The Bravo port for the extension cable is on the back of the junction box. The following figure shows the junction box connections.

Figure Junction box connections (front view and back view)

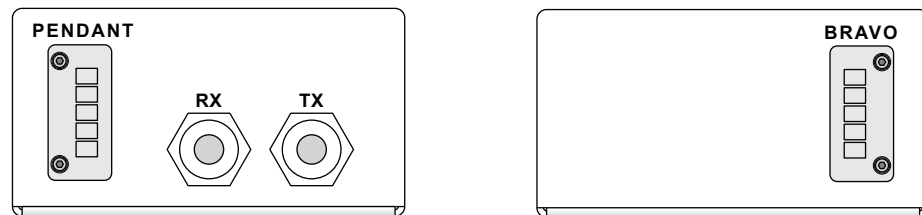

To use a junction box to connect the Standard Light Curtain:

Refer to the following figure and table to connect the junction box to the Standard Light Curtain.

Figure Standard Light Curtain connections using a junction box

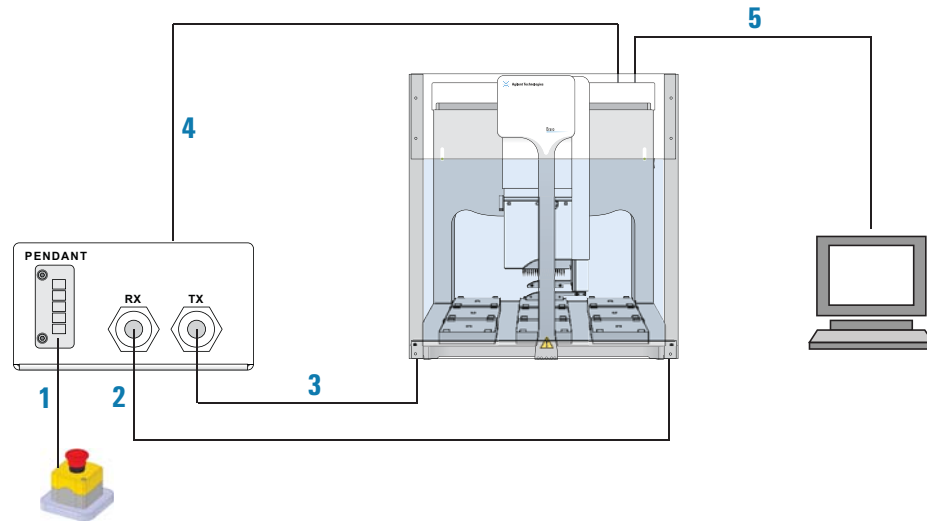

Item	Description	From	To
1	Pendant cable	Pendant	Junction box: PENDANT port (front)
2	Lightpost cable, black	Lightpost receiver	Junction box: RX port (front)
3	Lightpost cable, gray	Lightpost transceiver	Junction box: TX port (front)
4	Extension cable	Pendant port on the Bravo connection panel	Junction box: BRAVO port (back)
5	Ethernet cable	Bravo connection panel	Controlling computer panel

Aligning the light beams

To align the light beams:

- 1 On the side of the Bravo Platform, press the power switch to the **on** (I) position.
The two indicator lights on the front of the Bravo backplate illuminate, indicating that the Bravo Platform is on, and the Standard Light Curtain activates.

2 Installing the Bravo Platform

Installing the Standard Light Curtain and shields

Figure Bravo Platform status lights (front) and power switch (right side)

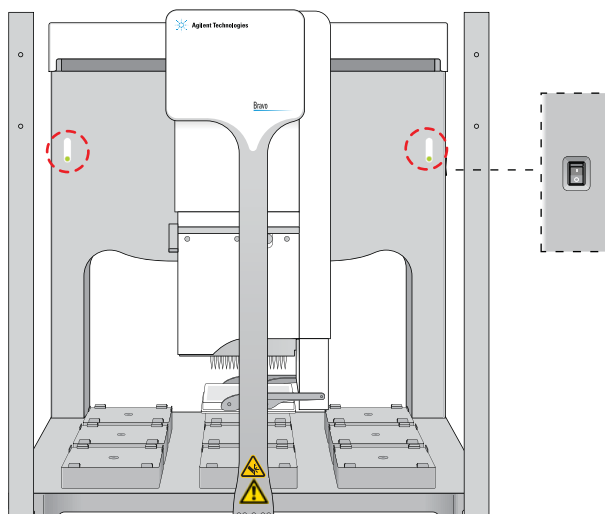

- 2 On the lower inside panel of each lightpost, verify that the column of LEDs turn on.

Figure Lightpost LED lights

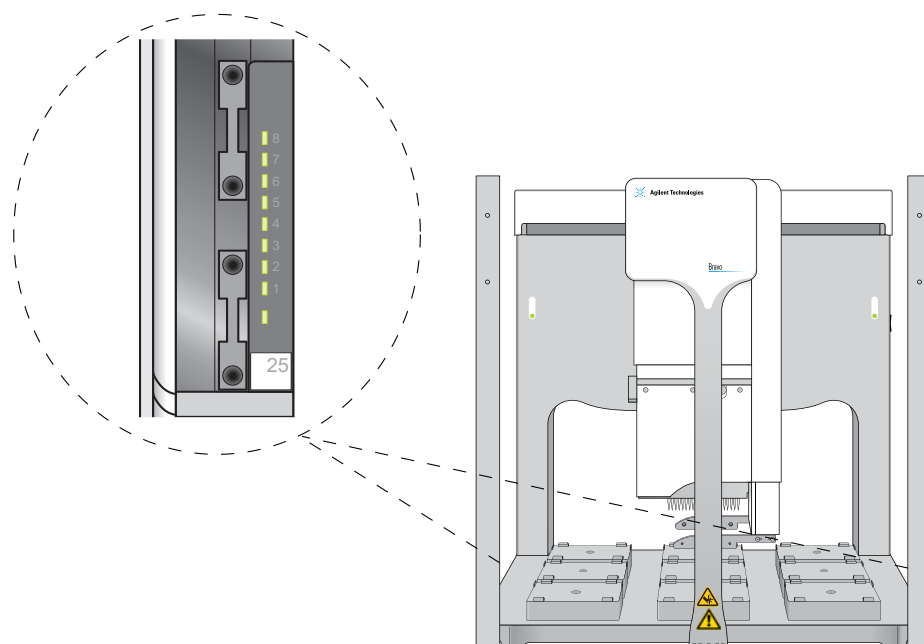

- 3 While facing the front of the Bravo Platform, slowly rotate the LED panels forward as far as possible, so that the LED panels are angled to face toward you.

The LED lights at the bottom of the glass panels turn red, indicating that the light beams are not aligned.

CAUTION Avoid touching the glass panels with your fingers. Fingerprints or dirt on the glass can interfere with the Standard Light Curtain operation.

- 4 Slowly rotate the LED panels backwards again until the entire column of LEDs on each panel turns solid green, indicating that the light beams are aligned.

The two indicator lights on the front of the Bravo backplate turn blue.

IMPORTANT If any of the LEDs on the lightpost panel are partial green or blinking, the light beams are not completely aligned. On the front of the Bravo backplate, the two indicator lights are red if the light beams are not aligned.

Figure Rotating the LED panels to align the light beams

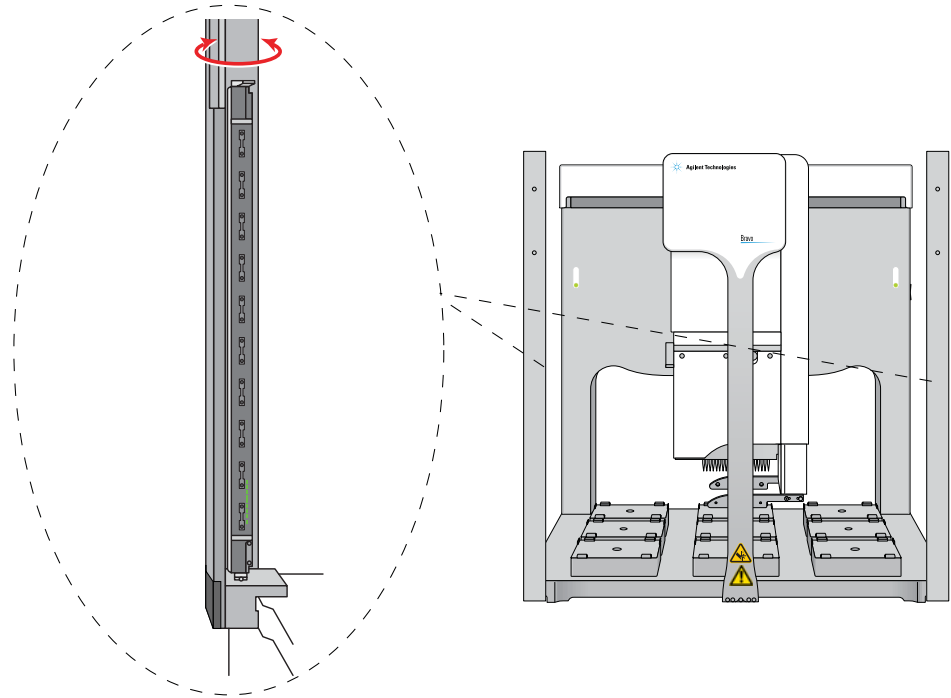

- 5 Use a 2.5-mm hex wrench to tighten the two adjustment screws located near the top and bottom of each lightpost's interior-facing side, as the following figure shows (1).

2 Installing the Bravo Platform

Installing the Standard Light Curtain and shields

Figure Adjustment screws (1) on the lightpost interior top and bottom

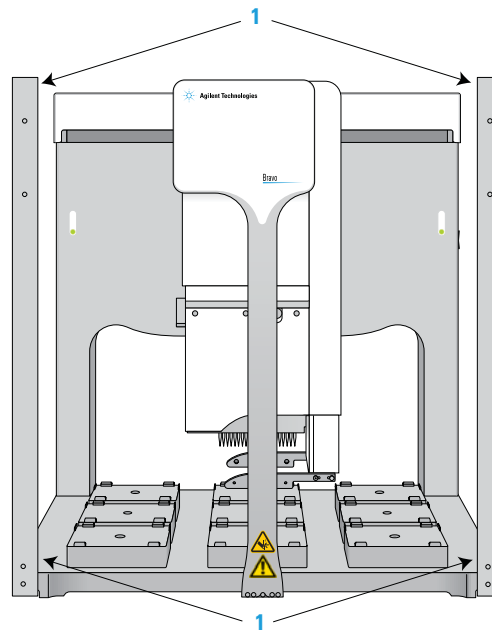

6 To verify the adjustment:

- a** Press the Bravo power switch to the **off (o)** position, wait a minute, and then press the power switch to the **on (|)** position.
- b** Verify that the entire column of LEDs on each lightpost are solid green and not blinking.

Installing the front shields

Before you start

Remove the protective backing from the shields.

If necessary, use a soft, lint-free cloth and isopropyl alcohol to clean the shields.

To install the front shields:

- 1** At the front of Bravo Platform, position the upper front shield so that the side with the countersink screw holes is facing away from the device.
- 2** Secure the upper front shield to the top of the two lightposts using the four screws provided.
- 3** Position the lower front shield so that the side with the countersink screw holes is facing away from the device.
- 4** Secure the lower front shield to the two lightposts using the four screws provided.

After installation, the flat screw heads should be flush with the shield surface.

Figure Bravo Platform front shield attachment screws

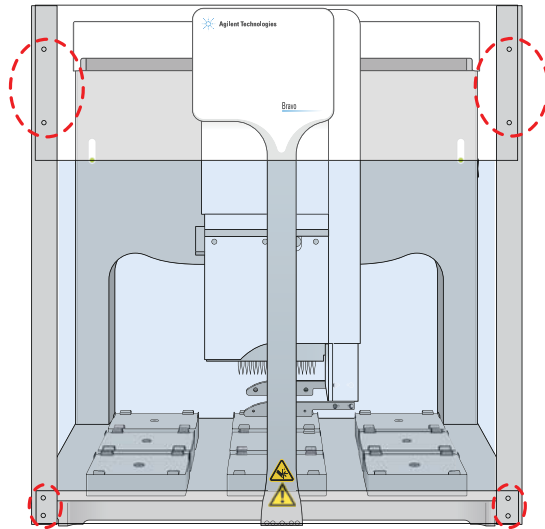

Installing the side shields

The Bravo side shield configurations can vary depending on whether the Bravo Platform is integrated with another device at a given side. The options include:

- *Full-size side shield.* Prevents access to the Bravo moving parts from the side. The full-size shield is used on a side where no device is integrated.
- *Upper side shield.* Prevents access to the Bravo moving parts at the upper side only. For example, the upper shield could prevent an operator from reaching over a device with a low profile that is integrated at the side of the Bravo Platform.
- *Partial-width shield.* Prevents access from the side to certain deck locations only. For example, if a device is integrated at the side aligned with the back row of platepads, a partial side shield can prevent access to the other rows of platepads that are not blocked by an integrated device.

The procedure in this section describes how to install the full-size side shield. Refer to the following figure and table for this procedure.

2 Installing the Bravo Platform

Installing the Standard Light Curtain and shields

Figure Full-size side shield installed on the Bravo Platform (side view)

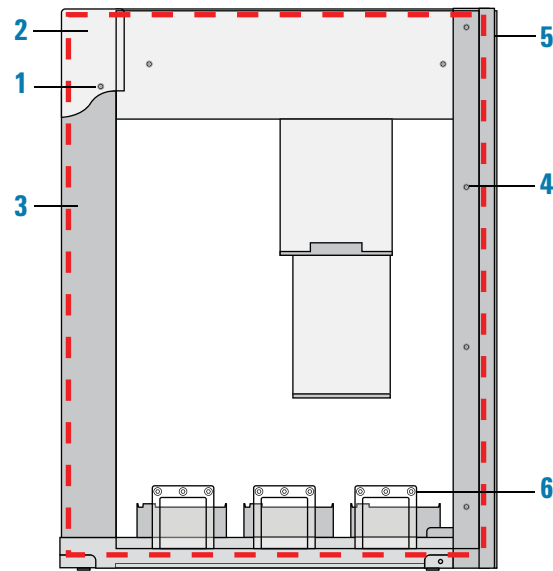

Item	Description
1	Top cover attachment screw
2	Top cover
3	Backplate
4	Shield attachment screws (four)
5	Lightpost (Standard Light Curtain)
6	Shield deck-access window (three)

To install the side shield:

- 1 At the side of the Bravo Platform, remove the screw (1) that attaches the Bravo top cover (2) to the Bravo backplate (3).
- 2 Use the screw provided with the side shield to secure the side shield to the Bravo top cover.
- 3 Using the four attachment screws (4) provided, secure the side shield to the lightpost (5).
- 4 Install covers on up to three deck-access windows (6) in the shield unless tubing or cabling access is required through the given window. Three T20 M4 8-mm screws secure each window cover to the rear shield to prevent access through the window opening.
If applicable, route tubing or cables through a deck-access window where no cover is installed.

Installing the rear shield

About this topic

Read this topic if you have a Bravo Platform that will be operated in an area where access to the moving parts is possible through the rear opening in the backplate. This topic describes how to install the rear shield to protect operators from moving-parts hazards while the device is in operation.

The rear shield is not necessary if the back opening of the Bravo Platform is not accessible to operators, for example, if the back opening is against a wall.

Before you start



WARNING To prevent potential injury, turn off the Bravo Platform and disconnect the power cord before you install or remove any accessory.

Make sure that you have the following:

- Rear shield kit
- Cross-tip screwdriver
- 2.5-mm and 3-mm hex wrenches
- T10 and T20 Torx drivers

Installing the rear shield

The following figure shows the installed rear shield, which is a clear panel that blocks rear access to the deck through the opening in the Bravo backplate.

Figure Bravo Platform with rear shield installed

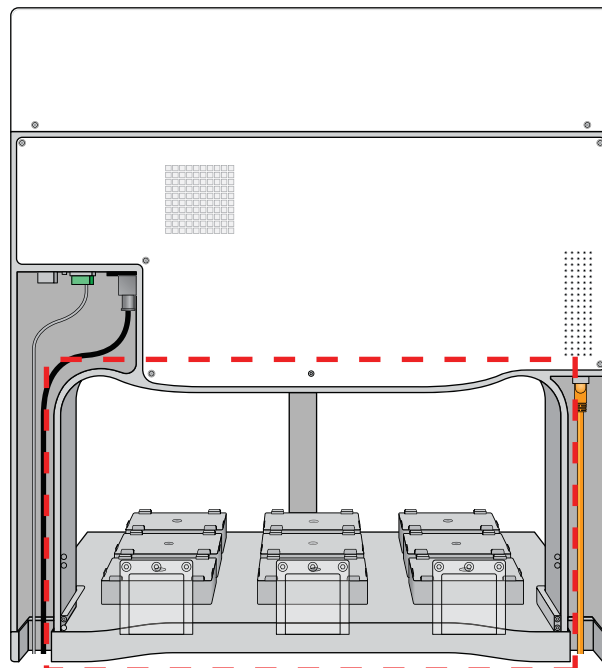

2 Installing the Bravo Platform

Installing the rear shield

To install the rear shield:

- 1 On the side of the Bravo Platform, press the power switch to the **off (o)** position (1), and unplug the power cord (2). See the following figure.

Figure Bravo Platform rear view

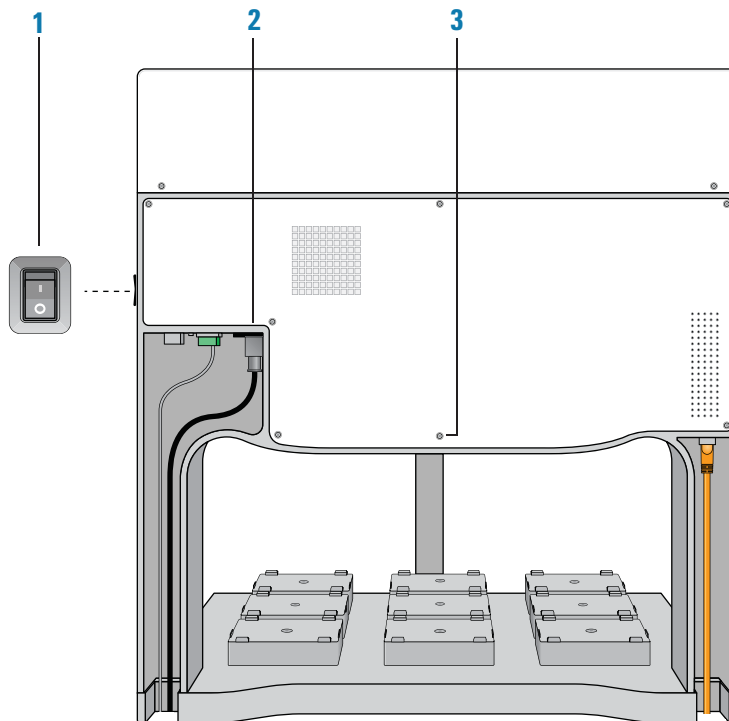

- 2 At the back of the Bravo Platform, remove the screw from the center lower edge of the rear cover (3), as the preceding figure shows. Save the screw for future use in case the shield is removed.
- 3 If applicable, route tubing or cables from any on-deck accessories through one of the three deck-access windows in the rear shield.
- 4 While holding the shield in place to cover the rear deck opening, use a T10 driver to install the screw (M3) at the top center of the shield into the screw hole in the Bravo backplate.
- 5 At the bottom of each Bravo backplate post, position a shield clamp on the interior. See the following figure.

Figure Rear shield clamp in position on Bravo backplate post (view from interior)

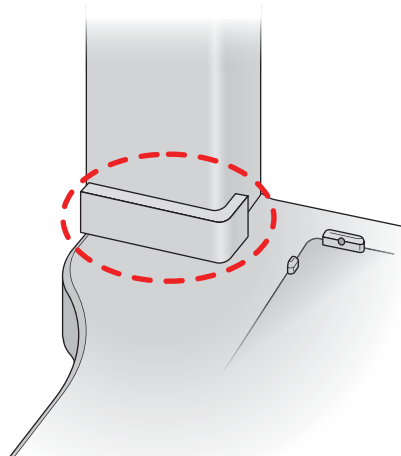

Note: The clamps are secured in place after the shield screws are installed in the next step.

- 6 Using a T20 driver, install the two M4 screws in the rear-facing end of each clamp to secure the shield to the clamps, as the following figure shows.

Note: The preferred location for the rear shield clamps is at deck level. If something interferes with the deck-level position of a clamp, you can use the optional attachment holes on the shield to position the clamp higher on the post. In this case, you should keep the second clamp at deck level if possible.

Figure Detail of screws installed in clamp on rear post

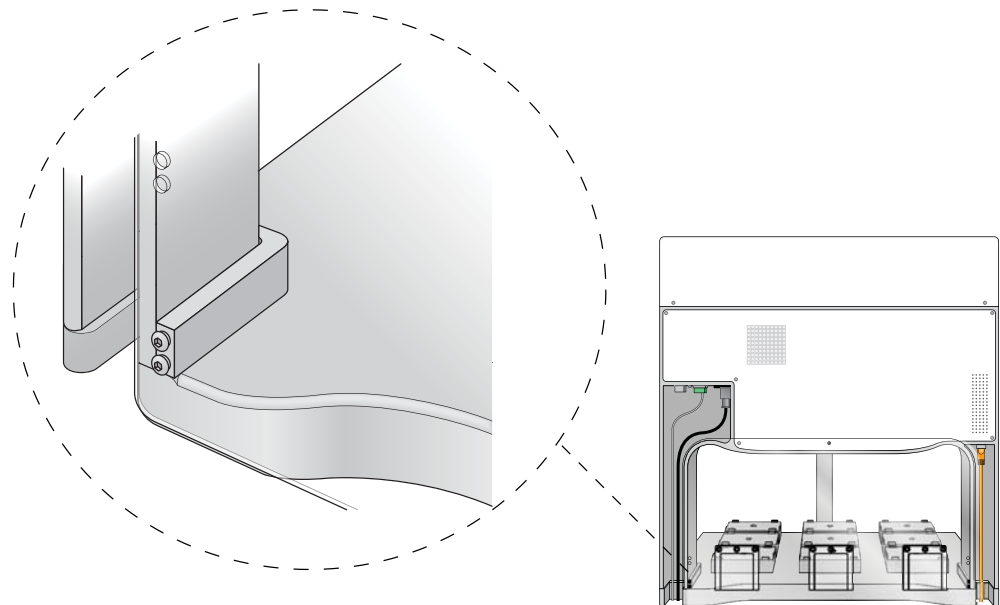

- 7 Use a T20 driver to install the covers on the three deck-access windows in the rear shield, unless tubing or cabling access is required. Three M4 8-mm screws secure each window cover to the rear shield to prevent access through the window opening.

Installing the dust cover

About the Bravo dust cover

The Bravo dust cover is a clear plastic cover that sits atop a Bravo Platform fitted with a Standard Light Curtain.

Figure Dust cover (1) top view, and (2) installation on a Bravo Platform with Standard Light Curtain

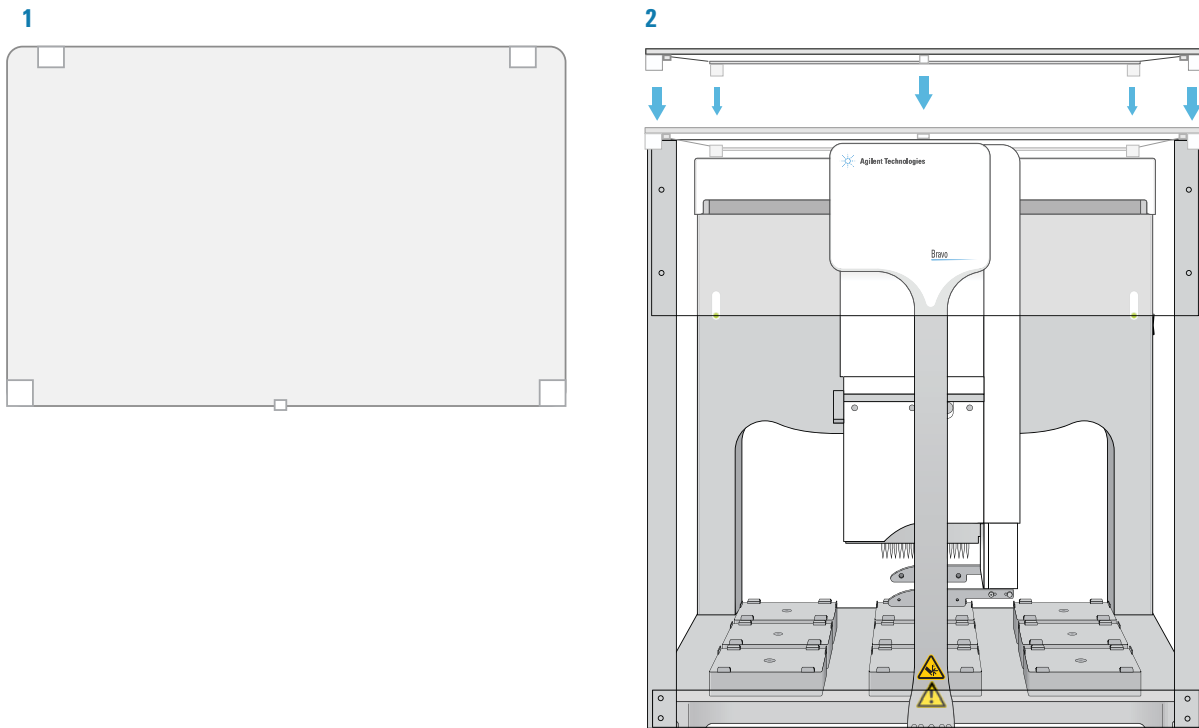

Installing the dust cover

To install the dust cover:

- 1 Ensure that the Bravo power switch is set to the **off (o)** position.
- 2 Orient the dust cover so that the side with the middle spacer is at the front of the Bravo Platform.
- 3 Position the dust cover on top of the Bravo Platform as follows:
 - The two corner spacers rest on top of the lightpost corners, which are installed at the front of the Bravo deck. The middle spacer rests on top of the front shield.
 - The two rear spacers rest on the top cover of the Bravo backplate.

Removing the dust cover

To remove the dust cover:

- 1 Ensure that the Bravo power switch is set to the **off (o)** position.
- 2 Lift the dust cover up and off of the Bravo Platform.

Starting up and shutting down

About this topic

This topic describes how to start up and shut down the Bravo Platform when you are operating it as a standalone device. For instructions on how to turn on and turn off the Bravo Platform when it is integrated into a workstation or system, see the workstation or system user documentation.

Starting up the Bravo Platform

CAUTION Always turn off the Bravo Platform before installing or uninstalling a liquid-handling head. Failure to do so can damage the head electronics.

To start up the Bravo Platform:

- 1 Ensure that the main power cable and Ethernet are plugged into the connection panel.
- 2 Turn on any accessories, for example, Pump Module.
- 3 Turn on the computer and the monitor, and start the Microsoft Windows operating system.
- 4 If you have not already done so, install the liquid-handling head.
- 5 On the side of the Bravo Platform, press the power switch to the **on** (I) position.

The front panel status lights turn blue.

Note: If the emergency-stop pendant is pressed or absent, the status lights will turn red.

Figure Bravo status lights and power switch

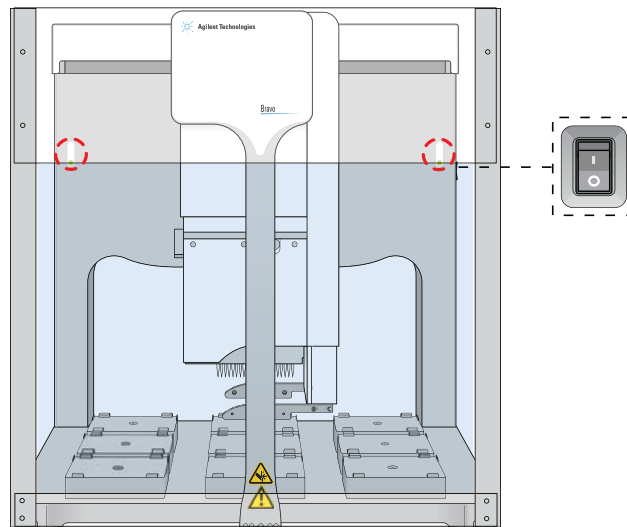

- 6 Start the VWorks software.

Shutting down the Bravo Platform

Shut down the Bravo Platform before you:

- Clean the Bravo Platform
- Change the liquid-handling head
- Install accessories
- Move the Bravo Platform

CAUTION Always turn off the Bravo Platform before installing or uninstalling a liquid-handling head. Failure to do so can damage the head electronics.

To shut down the Bravo Platform:

- 1** If removing the liquid-handling head, ensure that the disposable tips are removed.
- 2** Optionally, home the liquid-handling head.
- 3** Shut down the computer.
- 4** Turn off any accessories, for example, Pump Module.
- 5** If using an Auto Filling Reservoir, disconnect the bottles to prevent siphoning.
- 6** On the side of the Bravo Platform, press the power switch to the **off (o)** position.
- 7** If applicable, uninstall the liquid-handling head.

Related information

For information about...	See...
Setting up and using the Bravo Platform	<i>Bravo Platform User Guide</i> For details on how to access this guide, see “Where to find user information” on page vii.



Safety and Installation Guide

G5563-90002

Revision A, October 2017