

Agilent Turbo-V 3K-G System



Product description

The Agilent Turbo-V 3K-G high-throughput turbomolecular pump is a dedicated vacuum pumping system, designed specifically as a turbo pump for thin film deposition equipment. Its pumping stages, and the entire pump structure, are optimized to work with very high flows of argon under high temperature load.

This robust turbo pump is suitable for harsh manufacturing environments because of its rugged design. Typical industrial vacuum coating applications include solar and flat panel display manufacturing. The pump's robust design and its advanced integrated electronics make the Turbo-V 3K-G the optimum pumping solution for the vacuum coating industry.

Features and benefits

The only truly “integrated” system in the market

The Turbo-V 3K-G: an advanced solution for thin film applications

- Fully integrated system with on board waterproof power supply
- Vent/purge valves control capability
- Integrated diagnostics
- Multiple interfaced capability
- Lowest power absorption

Best footprint-to-performance ratio

- The highest argon pumping speed (2,050 L/s) for its size allows uniform deposition rates at high substrate throughput
- Highest pumping speed in its class: 2,200 L/s for nitrogen
- Throughput: over 1,400 sccm for nitrogen
- The all-turbo, more compact rotor design delivers highest performance with the smallest footprint

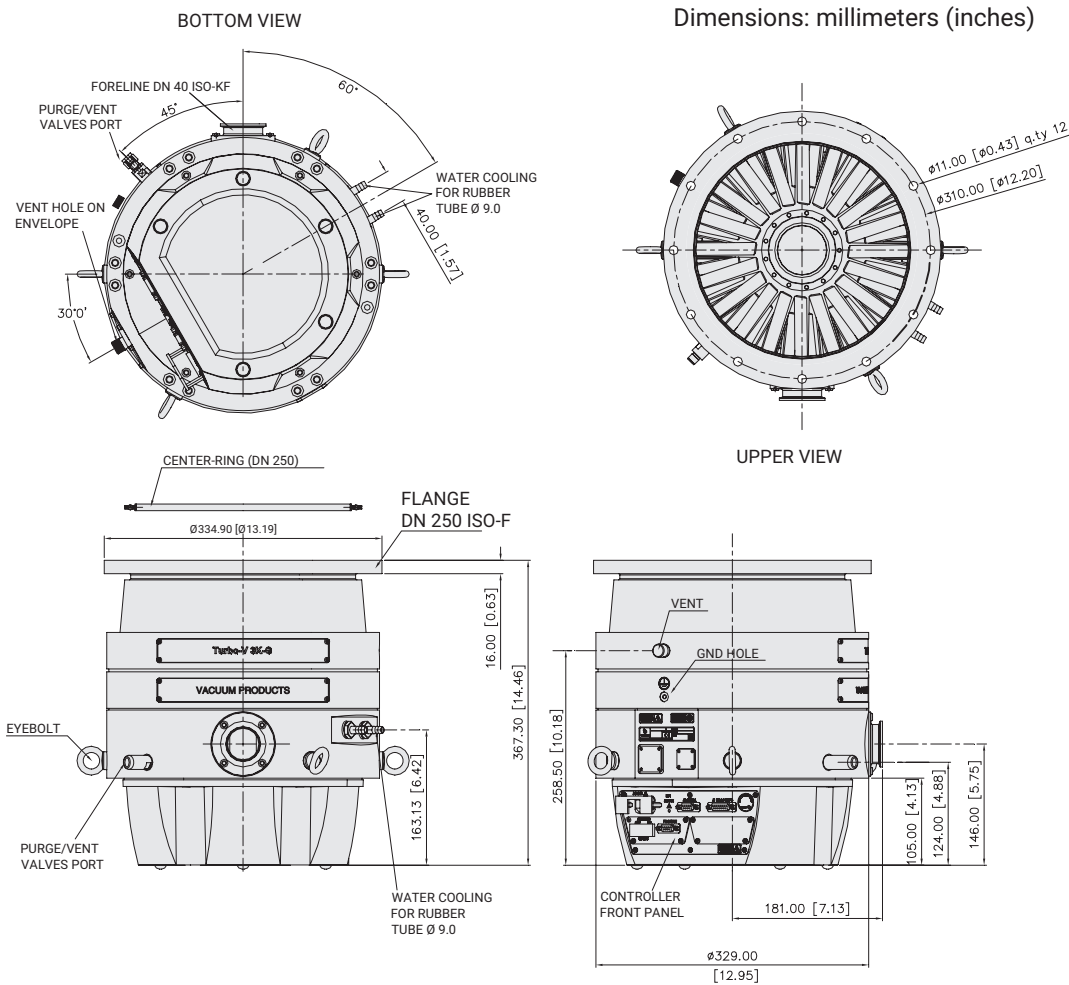

Technical specifications

Pumping Speed	N ₂ : 2,200 L/s He: 1,900 L/s Ar: 2,050 L/s
Compression Ratio	N ₂ : >1 × 10 ⁷ He: 6 × 10 ⁵ Ar: >1 × 10 ⁸
Base Pressure* (with Recommended Forepump)	<1 × 10 ⁻⁸ mbar
Inlet Flange	DN 250 ISO-F
Foreline Flange	DN 40 ISO-KF
Nominal Rotational Speed	31,800 rpm
Start-Up Time without Gas Load and with the Recommended Forepump	<6 minutes
Foreline Pressure	<0.5 mbar
Minimum Recommended Forepump	>60 m ³ /h (depending on gasflow requirements)
Operating Position	Any
Cooling Water Requirements	Recommended flow: 200 L/h (0.89 GPM) Temperature: +15 °C to +30 °C Pressure: 3 to 5 bar (45 to 75 psi)
Weight	52 kg (114.63 lb)
Communications Interface	RS232 cable with a 9-pin D type male connector and a 9-pin D type female connector, Profibus optional

* According to standard DIN 28 428.

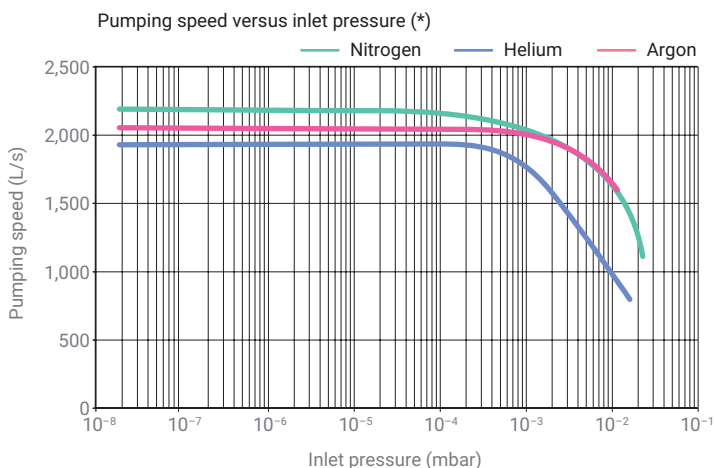

(*) Measured with a 60 m³/h forepump.

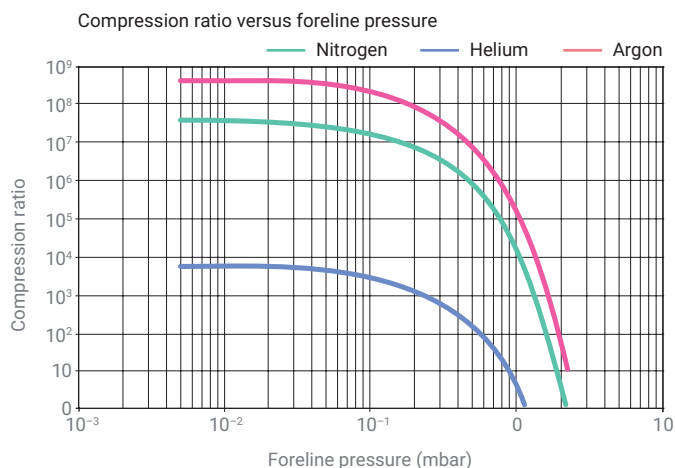

Ordering information

Description	Part Number
Pumping Systems (*)	
Turbo-V 3K-G system	9698888
Turbo-V 3K-G system with Profibus	9698889

(*) Pumping systems include pump with 230 V integrated electronics, water hose connection, inlet screen with center-ring and pre-installed IP54 mating connectors. 120 Vac units available on request.

Accessories	
Mains Cable NEMA Plug, 3 m Long	9699958
Mains Cable European Plug, 3 m Long	9699957
RS232 – Serial Cable	9699883
Water Cooling Kit for 6 × 8 mm (id × od) Flexible Hose	9699348
Water Cooling Kit for 3/8 in. id Flexible Hose	9699338
Water Cooling Kit for 9 mm id Flexible Hose	9699825
Turbo-V Remote Cable, 5 m Long	9699945
Turbo-V Remote Display Panel	9698850
Spare Parts	
IP54 Proof DB15 Mating Connectors	9698960
Inlet Screen DN 250 with Center Ring	9699138

www.agilent.com/en/product/vacuum-technologies/turbo-pumps-controllers/turbo-pumps/turbo-v-3k-g-pump

DE44249.587025463

This information is subject to change without notice.

© Agilent Technologies, Inc. 2021
Printed in the USA, May 5, 2021
5994-3097EN

Contact information

Americas

Agilent Technologies
121 Hartwell Avenue,
Lexington, MA 02421 USA
Toll free: +1 800 882 7426
vpl-customer@agilent.com

Europe, Middle East, Africa, India

Agilent Technologies Italia SpA
Via F.lli Varian 54,
10040 Leini (Torino), Italy
Tel: +39 011 9979 111
Toll free: 00 800 234 234 00
vpt-customer@agilent.com

China

Beijing Office Agilent Technologies
(China) Co. Ltd.
No.3, Wang Jing Bei Lu,
Chao Yang District,
Beijing, 100102, China
Toll free: 800 820 6778
Contacts.vacuum@agilent.com

For more information, please contact your Agilent representative or visit www.agilent.com/chem/vacuum where you can chat live with a vacuum expert.

