

Blood Alcohol Analysis

Agilent Technologies Analyzer Solution

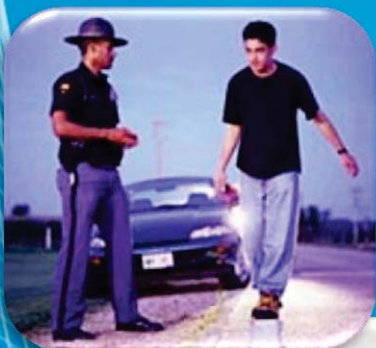

GPD Solutions
July 2013

For Forensic Use.

Blood Alcohol Concentration (BAC)

Market Overview

Concentration of Ethanol in a dilute aqueous biological sample is directly proportional to its concentration in the gas phase.

Countries have established limits for blood alcohol (mg/100 mL, or mg/dL) that constitute violation of local “driving impaired” regulations.

- In USA most states have set thresholds at 0.08 percent or 80 mg ethanol per 100 ml of whole blood.

BAC represents largest volume analysis for forensic Tox Labs

- Require accurate, defensible data
- Require short analysis and rapid cycle time

HSS-GC methods provide the most accurate test for BAC

For Forensic Use.

Dual Channel Blood Alcohol Analyzer

Single P/N Reduces Configuration Options

G3445B
Option #683

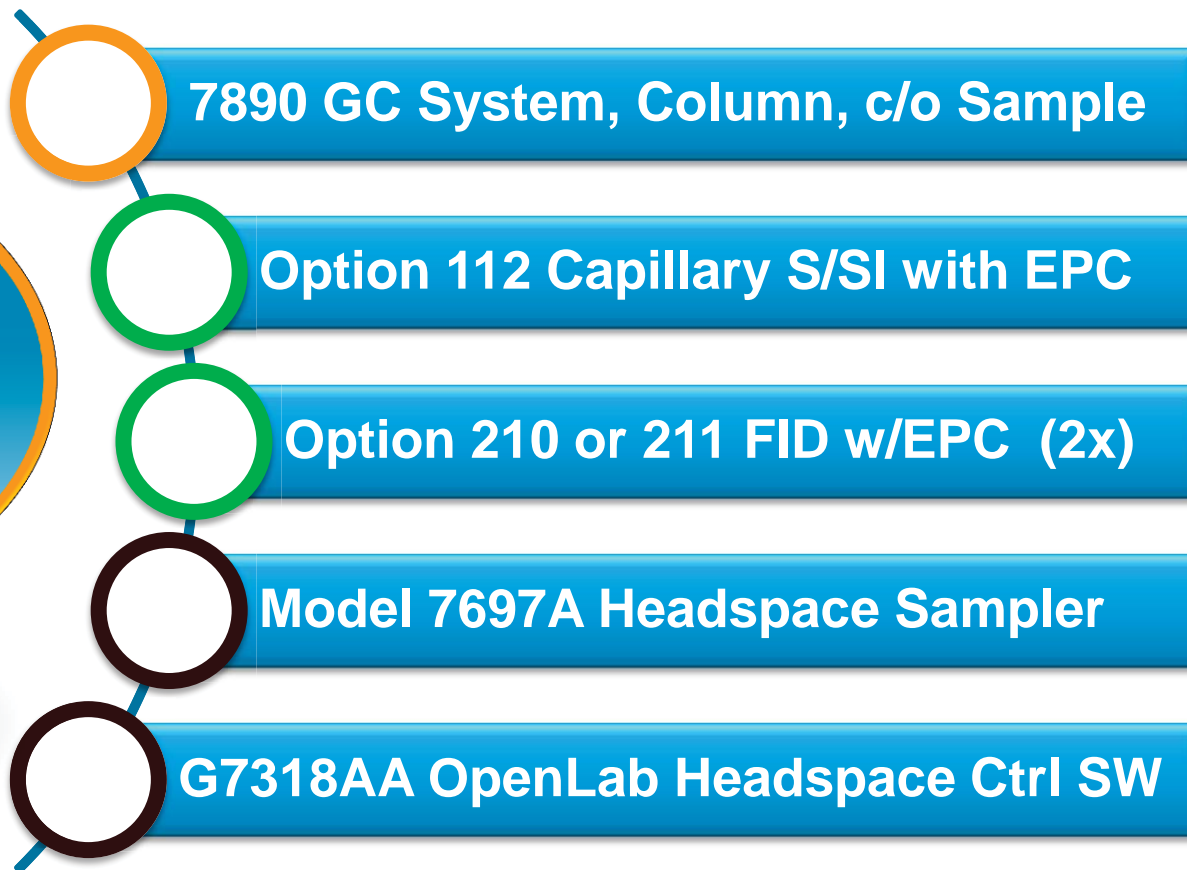

○ Not included with Analyzer

For Forensic Use.

Blood Alcohol Analysis

Potential Problems

- Headspace Sampler contamination
- Sample Carryover
- Systematic drifting of Ethanol controls
- Ethanol calibration non-linearity

For Forensic Use.

Dual Column Blood Alcohol System

G3445B#683 Schematic

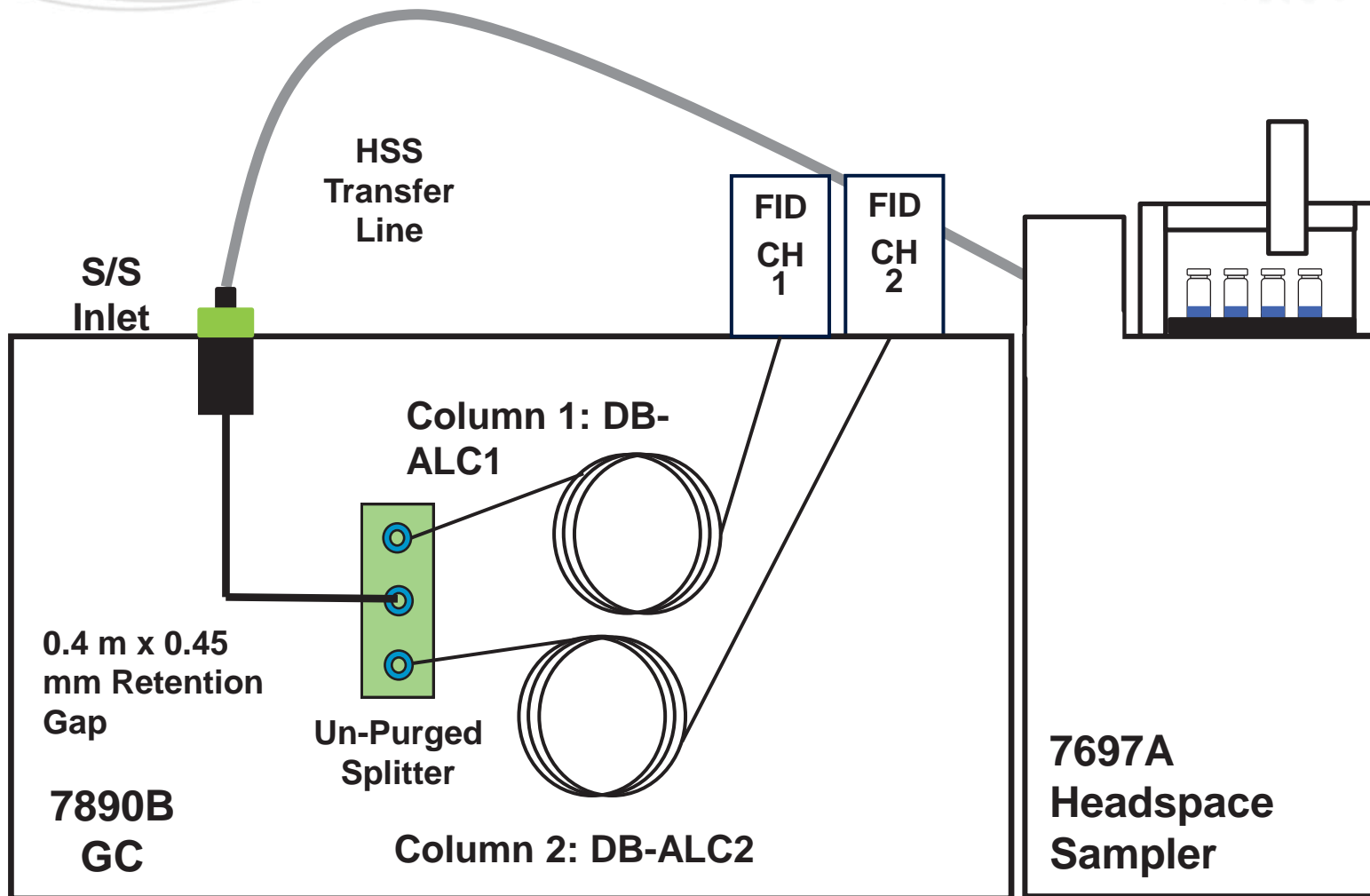

For Forensic Use.

Single Column Setup

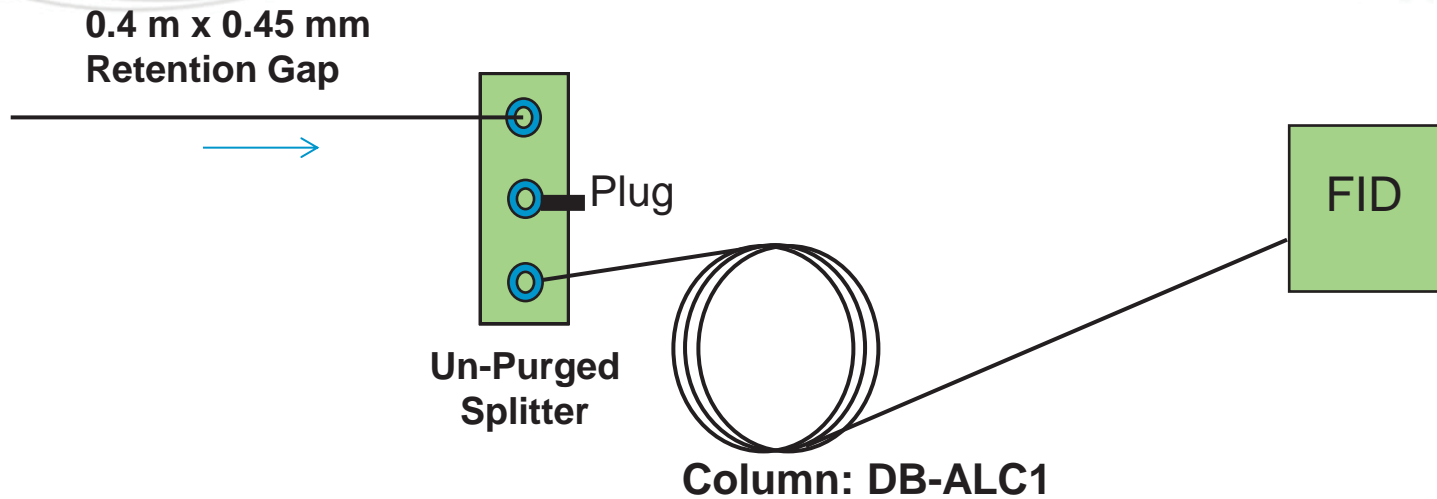

Plug must be in the middle port so that flow sweeps past and avoids dead volume

For Forensic Use.

Blood Alcohol Analyzer

System Overview

Headspace Sampler coupled to S/SL inlet

- Reproducible sampling across a wide calibration range

Dual Column-Dual FID configuration

- Provides differentiation of ethanol peak from potential contaminants
- Provides confirmation of ethanol presence with a single injection

Retention gap with deactivated fused silica

- Serves as guard column to protect analytical columns
- Easily replaced to facilitate maintenance

Un-purged splitter for dual column analysis

- Replaces problematic two hole ferrules or “Y” splitters
 - Eliminates leaks common to Y splitter
 - Overcomes uncertainty of two hole ferrules
- Precise reproducible split of sample between columns
- Provides reliable split of flow between columns



For Forensic Use.

Parameters

GC: 7890B

Inlet: Split/Splitless, 110 °C, He carrier

Inlet Pressure: 24 psi

Split Ratio: 10 to 1

Liner: Ultra Inert, 5190-2292 or 5190-4047

Oven Program: 40 °C for 4 min

Column 1: DB-ALC1, 30 m x 0.32 mm x 1.8 um

Column 2: DB-ALC2, 30 m x 0.32 mm x 1.2 um

FID Front and Rear: 250 °C

Internal Standard: n-propanol

Ethanol Calibration Standards: 50 mg/dl, 80 mg/dl, 100 mg/dl, 200 mg/dl, 300 mg/dl

Multicomponent Calibration Mix 1: Methanol, Ethanol, Isopropanol,, n-propanol @ 0.05%, 0.10%, and 0.40%

Multicomponent Calibration Mix 2: Methanol, Isopropanol, Acetone, n-propanol

For Forensic Use.

Headspace Parameters

Headspace sampler: 7697A

Vial pressurization gas: helium

Loop size: 1 ml

Vial size: 20 ml, shaking off

Caps: PTFE lined

Vial standby flow: 20 ml/min

Vial equilibration time: 7.00 min

Inject time: 1.00 min

GC cycle time: 4.50 min

For Forensic Use.

Headspace Parameters (cont.)

Oven temp: 70 °C

Loop temp: 80 °C

Transfer line: 0.53 mm ID deactivated fused silica through septum

Transfer Line temp: 90 °C

Vial fill pressure: 15 psi

Loop fill mode: custom, loop ramp rate 30 psi/min

Loop final pressure: 1.5 psi

Loop equilibration time: 0.05 min

Post injection purge: 200 ml/min for 3 min

Carrier controlled by GC

For Forensic Use.

Calibration Samples

G3440-85035: Ethanol Calibration Kit (Cerilliant part number E-034)

G3440-85036: Multicomponent Alcohol Calibration Kit (Cerilliant part number A-054) – 0.05% mix used as factory checkout

For Forensic Use.

The 7697A Vial Sampling Pneumatics

Designed to minimize carryover

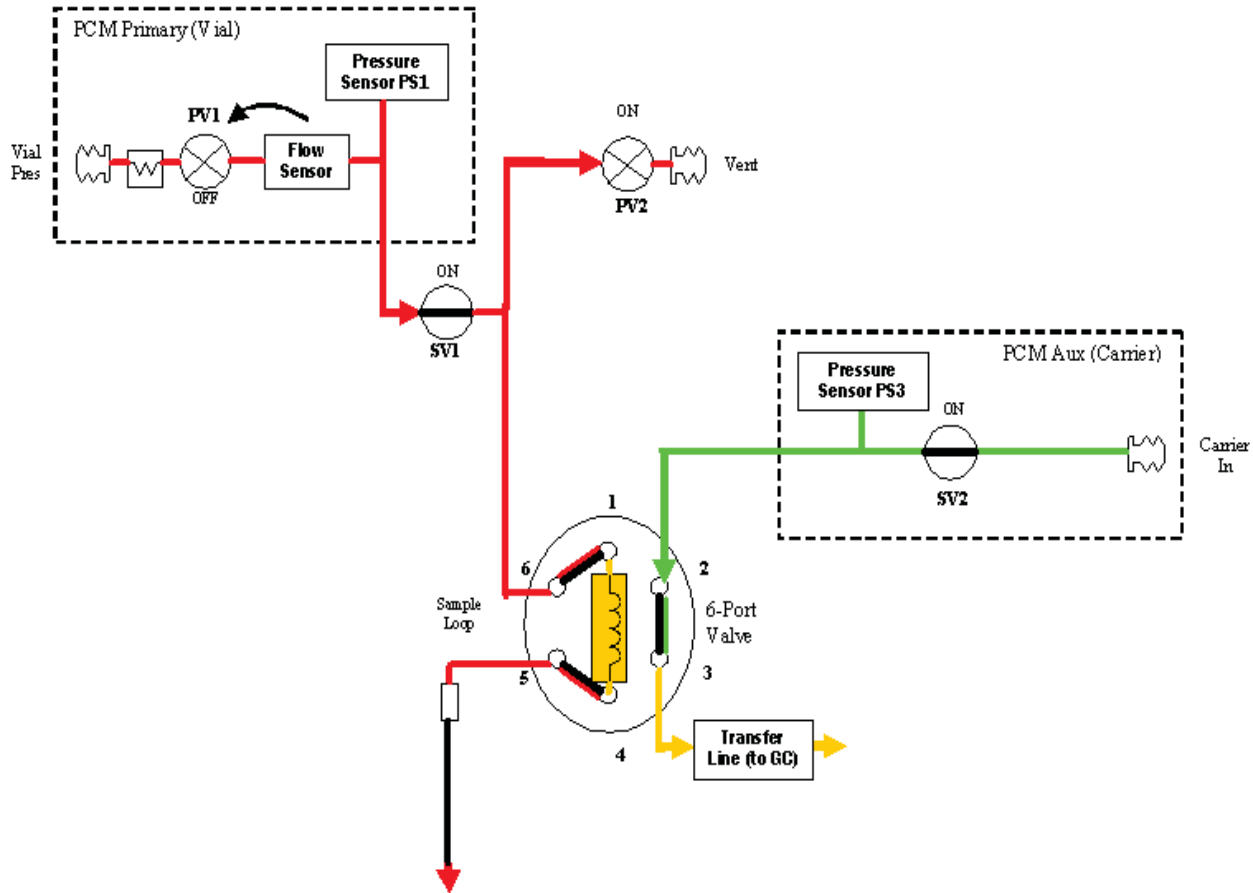

For Forensic Use.

BAC Analyzer System

Chromatographic Performance

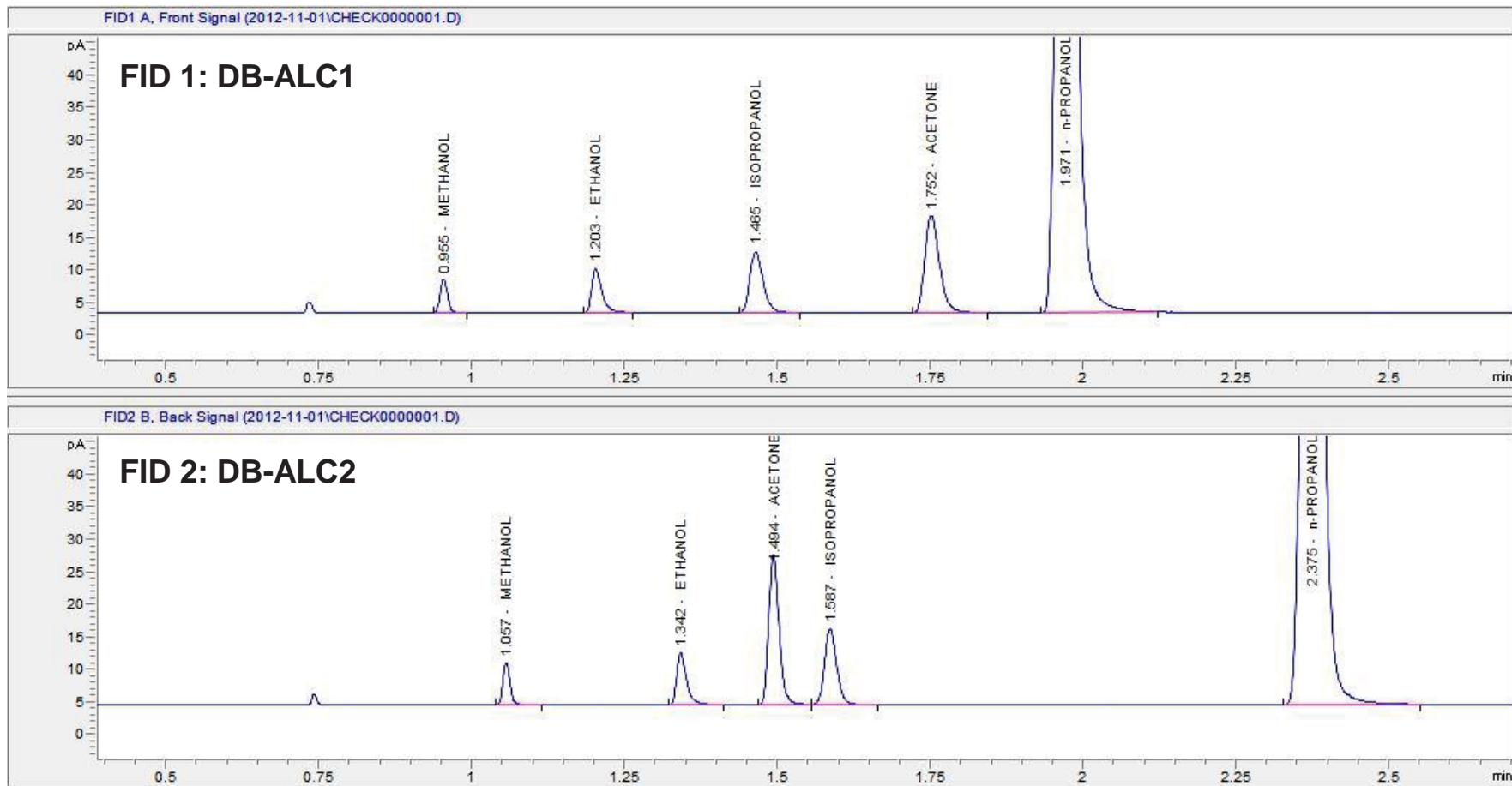

Ethanol and mixed volatile calibrator, n-propanol ISTD

For Forensic Use.

BAC Analyzer System

Chromatographic Performance

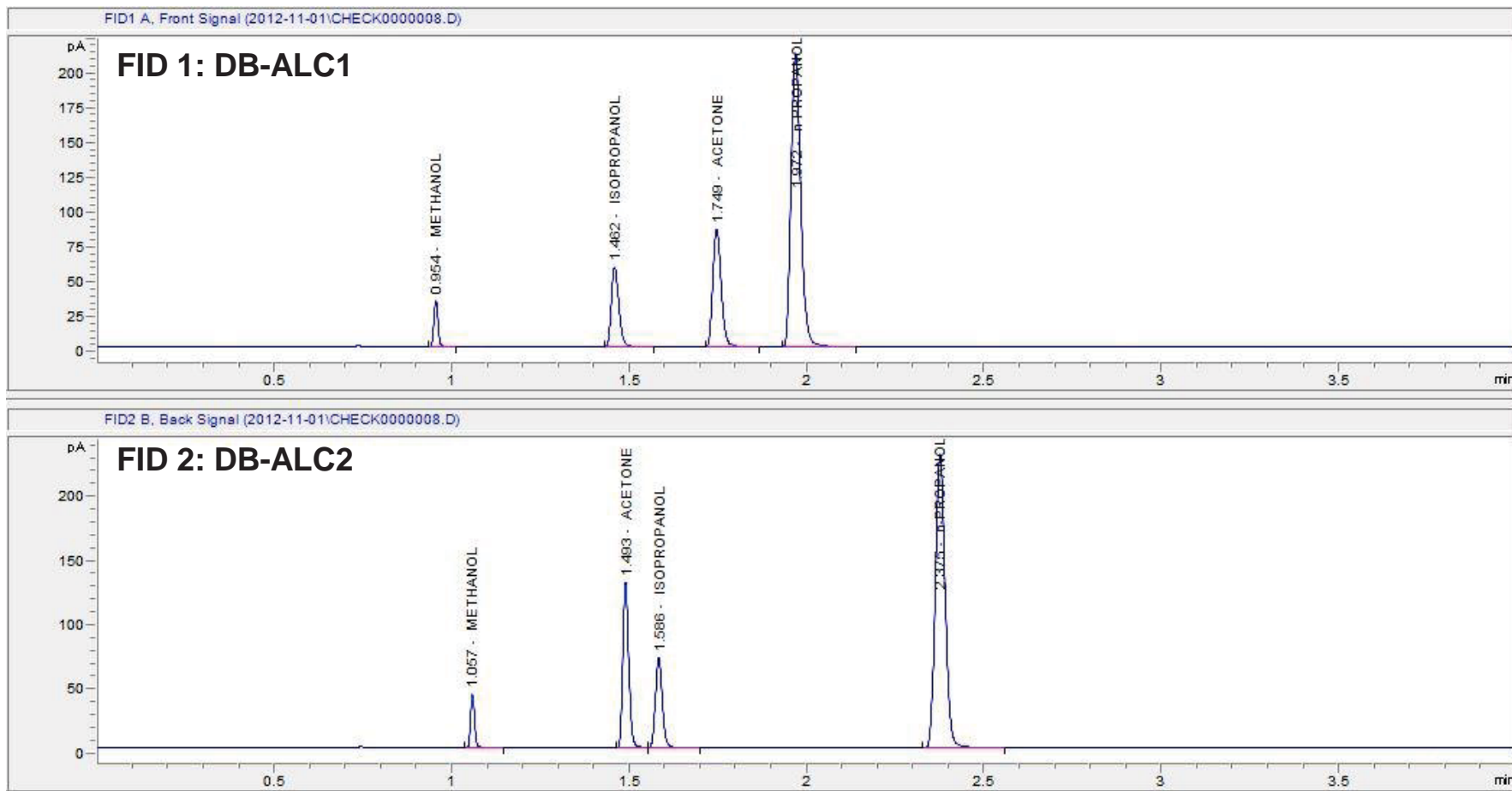

Multi-component control 0.05 % w/v per component without ethanol

For Forensic Use.

BAC Analyzer System

Chromatographic Performance

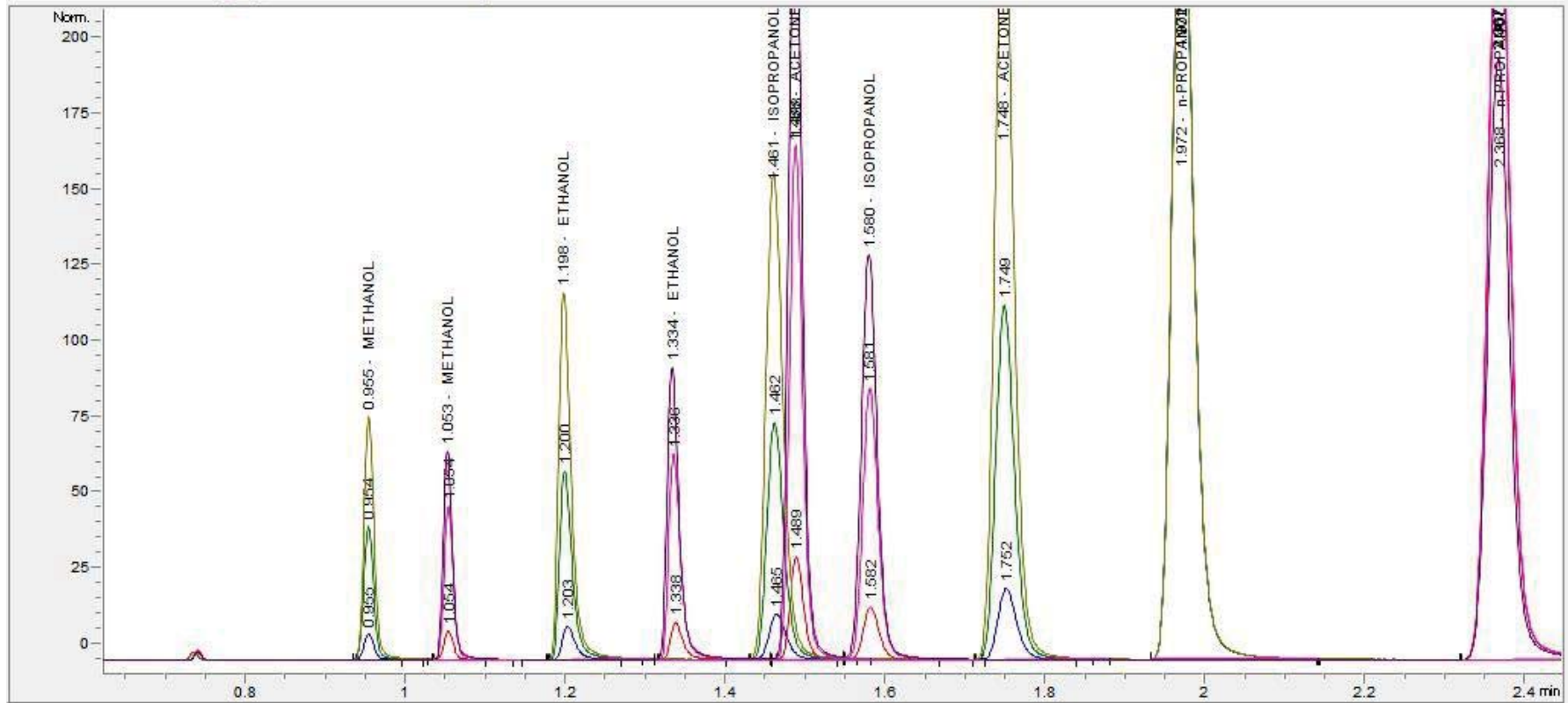

Overlay of multi-component calibrator mix - 0.01%, 0.05%, and 0.10% Conc.

For Forensic Use.

BAC Analyzer System

Chromatographic Performance

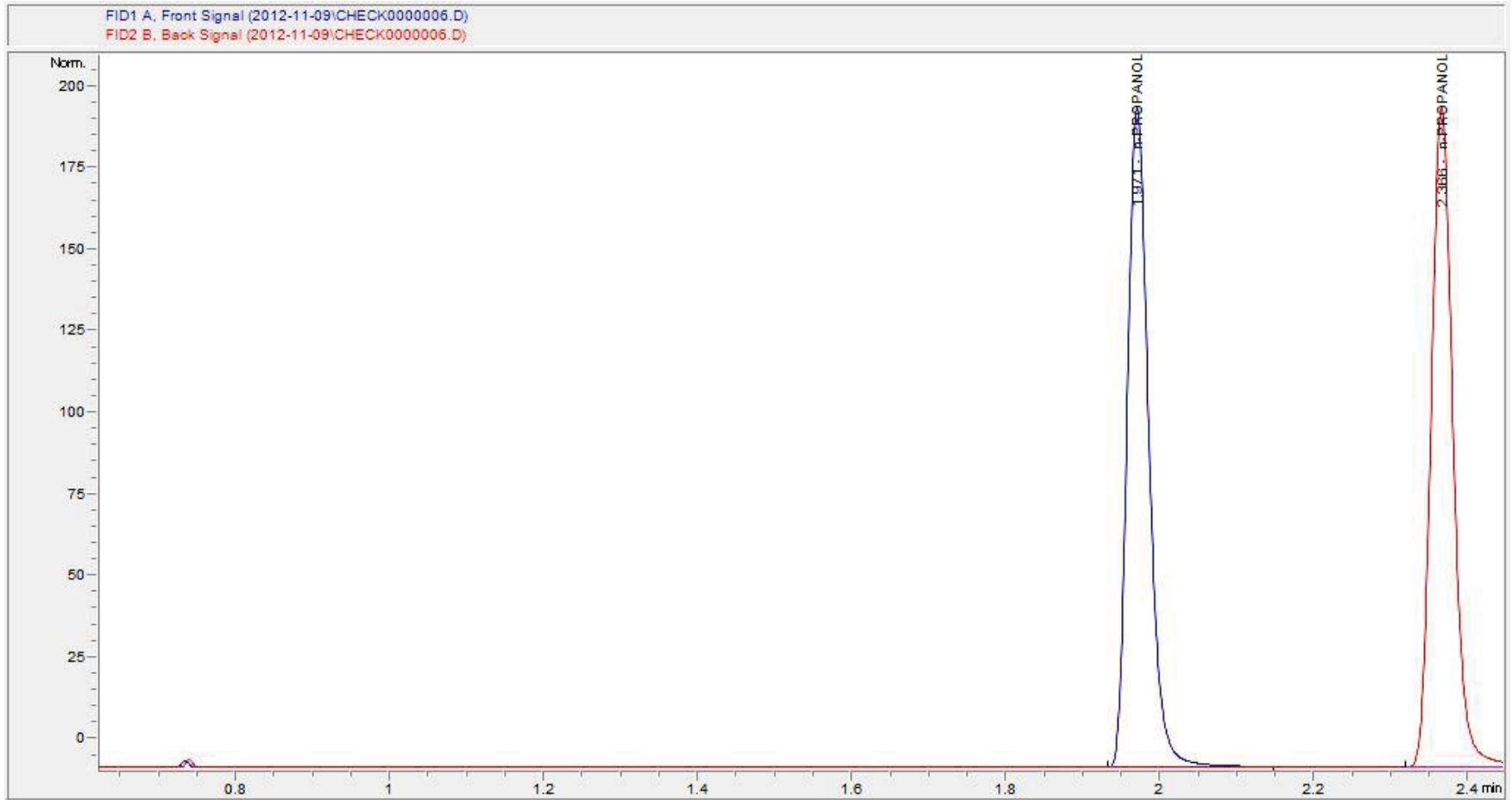

System blank run after 0.50 % ethanol control, n propanol ISTD

For Forensic Use.

BAC Analyzer System

Chromatographic Performance

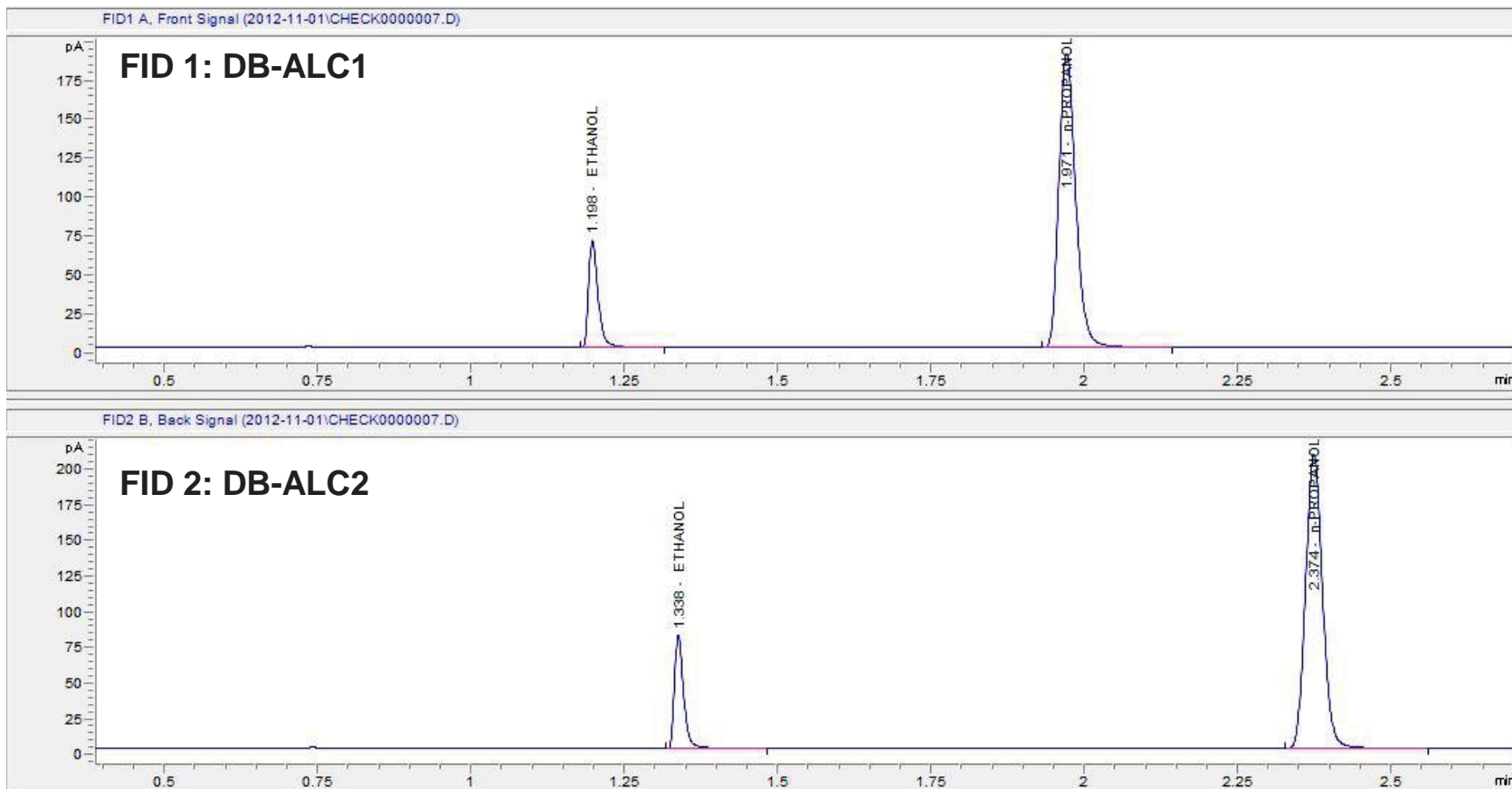

EtOH control sample at 0.08%, n propanol ISTD

For Forensic Use.

BAC Analyzer System

Chromatographic Performance

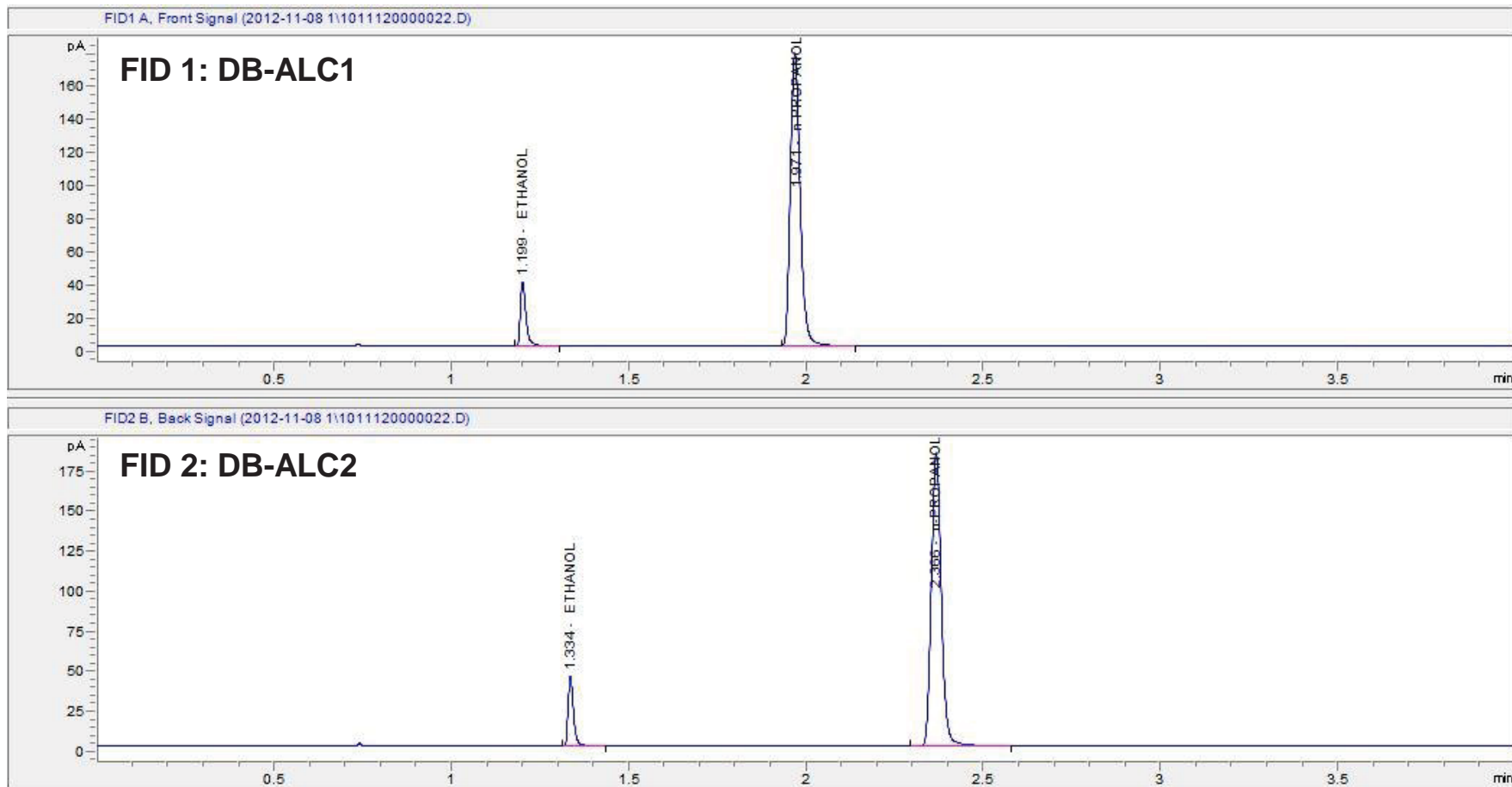

Ethanol control sample (0.05% conc.) with n-propanol ISTD

For Forensic Use.

BAC Calibration Levels

[0.5% sample (3x) – water blank – 0.01% sample (1x)] ←

DB-ALC1

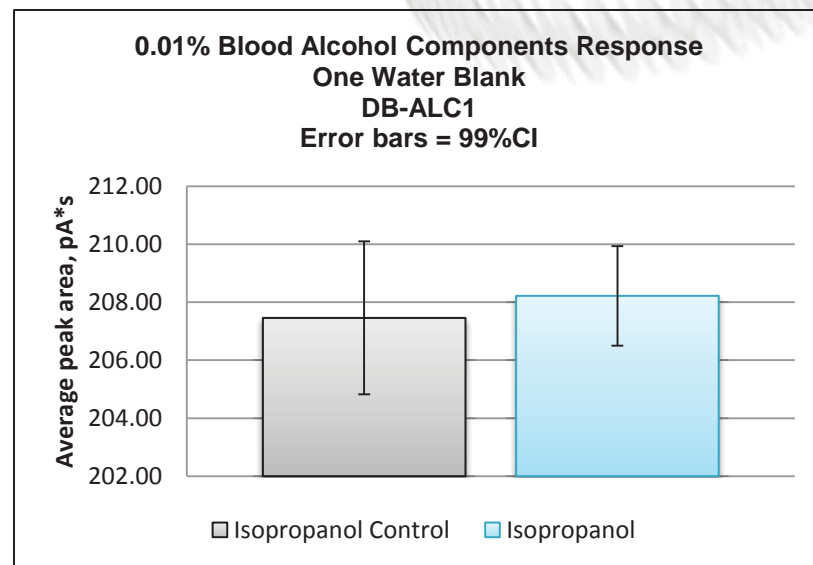
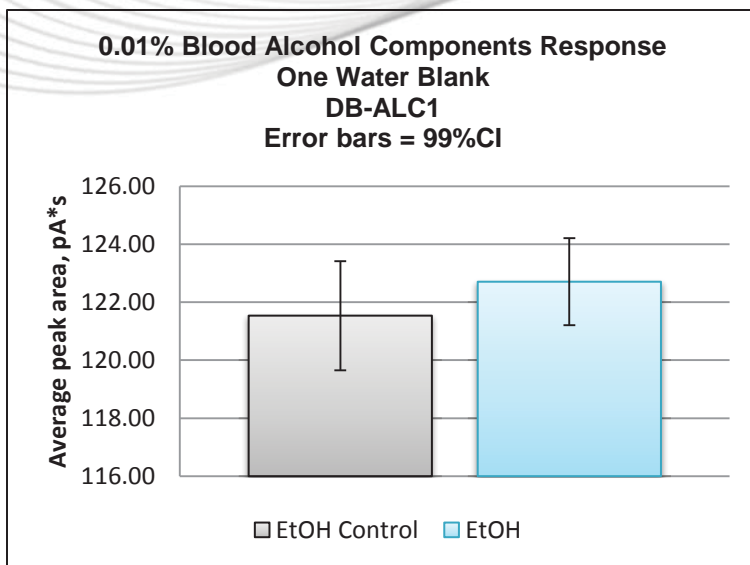

DB-ALC2

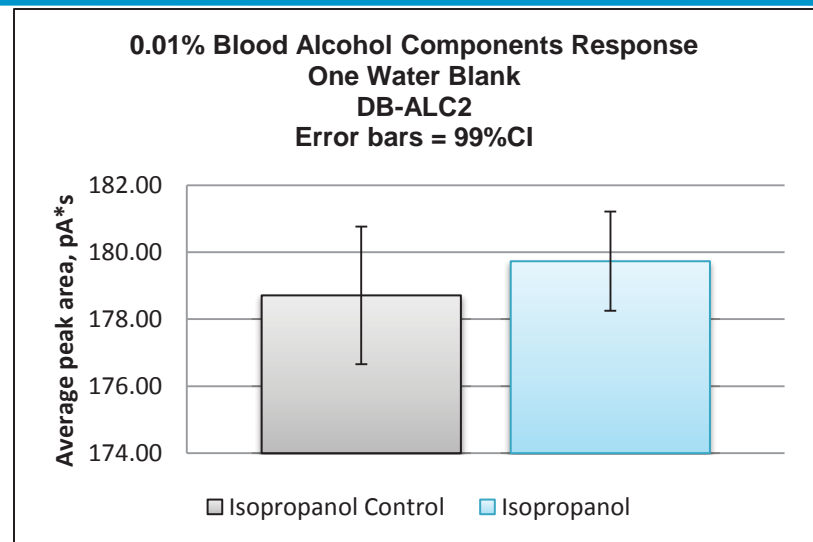
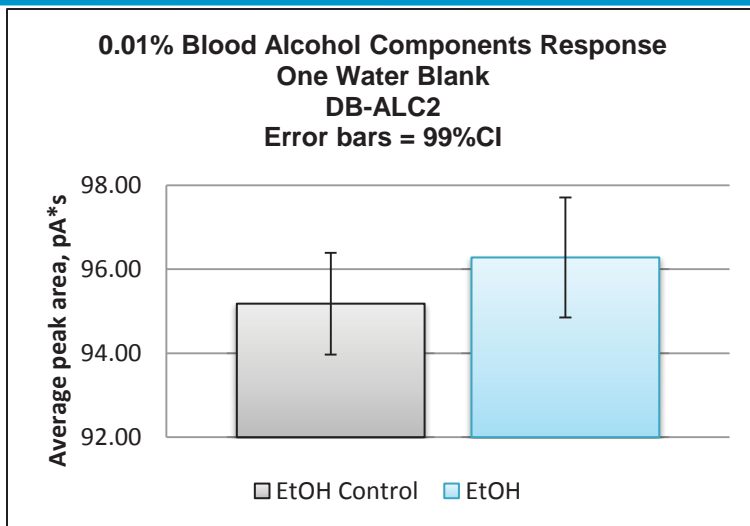

For Forensic Use.

BAC Calibration Levels Introduced as Priority Samples

- 0.05% Blood Alcohol components were put into sequence of 0.005% samples between vials 2 and 3
- Results show sequence performed correctly and running higher concentration priority vials did not adversely impact precision of lower concentration sample vials even though no blanks were run in between

Areas for 50ppm (0.005%) samples, (n=12) separated by 3 priority vials			
Areas	EtOH	Acetone	n-Propanol
Average	79.88	268.16	110.25
Stdev	0.30	0.94	0.52
RSD< %	0.38	0.35	0.47

Areas for 0.05% BAC components added as priority vials							
Areas	MeOH	EtOH	Acetone	IPA	Acetonitrile	Ethyl acetate	MEK
average	342.68	625.80	2223.03	1119.23	1155.34	5062.08	3981.46
stdev	0.20	0.57	7.30	1.12	1.55	36.04	18.51
RSD, %	0.06	0.09	0.33	0.10	0.13	0.71	0.46

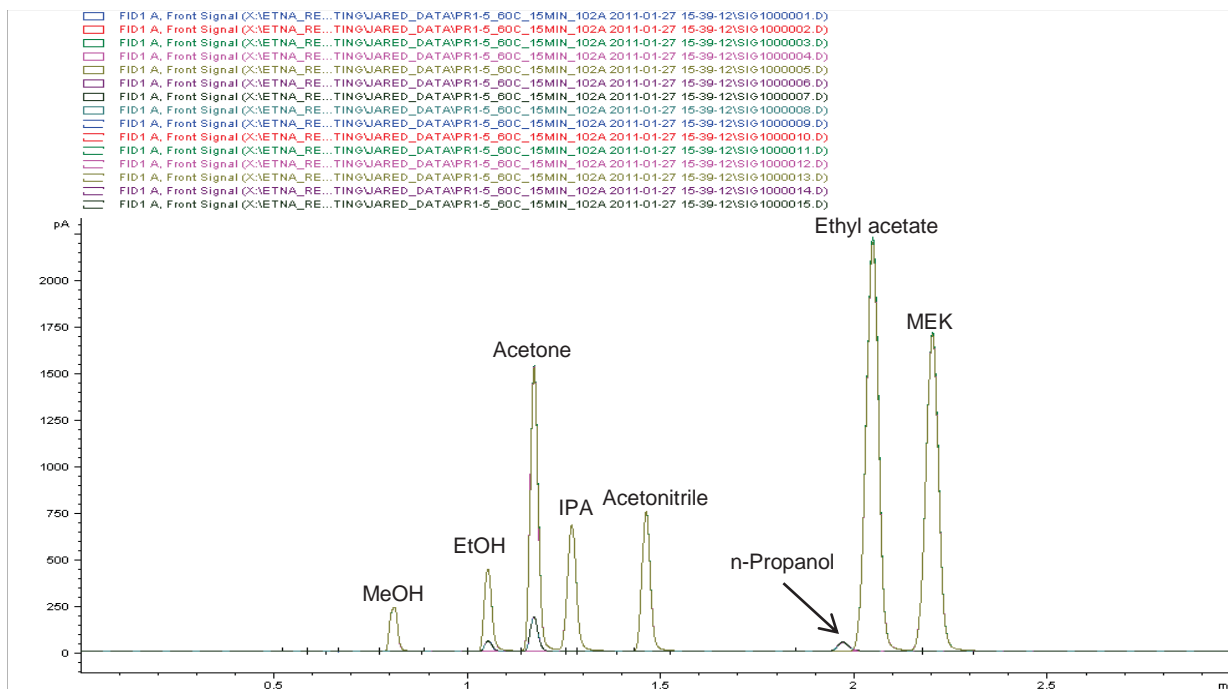

For Forensic Use.

K Factor

A good approach to checking system performance is the *System K factor*:

$$\text{System K} = (\text{area [n-propanol]}) \times (\text{EtOH std. conc.}) / (\text{area std. EtOH})$$

Calculation of Average K Factor, Result and Standard Deviation from Six replicates of 0.2 g/dL standard on DBAlc1

Run#	EtOH Area	IPA Area	K Factor	Requant Standards	Result (g/dL)
1	2338.07	3073.81	0.262935239		0.199248784
2	2338.68	3069.98	0.262539497		0.199549124
3	2347.03	3075.71	0.262094258		0.199888112
4	2340.35	3069.77	0.26233453		0.199705036
5	2360.65	3075.74	0.260584313		0.201046356
6	2352.83	3072.77	0.26119796		0.200574026
C(EtOH) = 0.2 g/dL		Average K = 0.261947633	Average Result =		0.200001906
IPA = ISTD		St Dev = 0.000885156	St Dev =		0.000676976
		RPD = 0.337913366	RPD =		0.338484811

For Forensic Use.

BAC Analyzer System

Recommended Operation for Sample Analysis

Daily calibration

- Analyze calibrators
- Negative control
- 0.08% ethanol control
- 0.10% Multicomponent mix
- Negative control injected immediately after 0.50% Ethanol calibrator to check for carryover

Batch sample analysis

- Analyze at least one control (0.08 g/dL suggested) before and after each batch or with every 10 injections
- Ethanol controls are 0.00%, 0.05%, 0.10%, 0.20%, and 0.30% (weight by volume)

Operation easily adapted to laboratory specific SOP

For Forensic Use.

Recommended Limits

Duplicate analysis should agree to within plus or minus 10% of their mean

Ethanol linear regression r^2 should be 0.995 or greater

For Forensic Use.

BAC Analyzer System

Performance Features

Benefits

- Pre-configured, chemically tested chromatography conditions
 - Includes parameters for headspace sampling
 - Facilitates laboratory implementation
 - Labs responsible for calibration and validation of the BAC analyzer
- Four minute run time
- Reproducible sample split and reliable column flow using CFT and EPC technology
- No carry over following challenge of the system with a 0.50% EtOH concentration sample
- Long term “System K factor” stability

$$\text{System K} = (\text{area [n-propanol]}) \times (\text{EtOH std. conc.}) / (\text{area std. EtOH})$$

For Forensic Use.